

MILESTONES



1980'S



1990'S

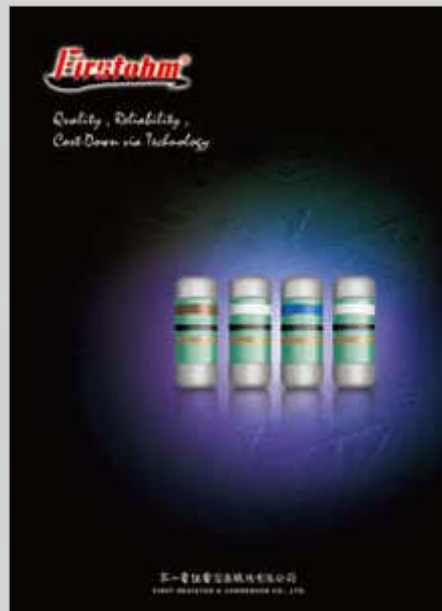

2012



1980'S



2010'S

Preface

Since the company's establishment in 1969, we at Firstohm have been constantly pursuing innovation and providing customers with quality products and reliable services in a cost-efficient and timely manner. Building operating culture on the belief in sustaining growth, pursuit of excellence, and most importantly, customer satisfaction, Firstohm will continue to be your valuable partner in the electronic component industry.

第一電阻電容器股份有限公司
FIRST RESISTOR & CONDENSER CO., LTD.



Certificate No. FM 577844



Certificate No. EMS 594693

Contents

Product Summary

Application Reference Table

Product Datasheets

Appendices

Resistance Values to IEC-Standard







Common Datasheets

Part Number Construction

Product(s), photos, specifications or data provided herein may be changed at any time without prior notice. Statements by Firstohm of product feasibility in certain application(s) are based on Firstohm's knowledge of performance characteristics that are typically required in particular applications. Please confirm technical specifications before placing orders.

Copyright © 2014 First Resistor & Condenser Co., Ltd.
Registered Trademarks © First Resistor & Condenser Co., Ltd.

All rights reserved. The contents of this publication may not be reproduced in whole or in part without prior consent of the copyright owner. Printed in Taiwan.

Resistor	Key Features	Power Rating	Ohm Range	Tolerance	Page
	<p>C3 Composite Film-Type Ceramic Composition Resistor</p> <ul style="list-style-type: none"> • Innovative and cost-effective C3 technology (NOTE 1) • Conforms to ANSI/AAMI norm EC53:1995/(R)2008 5.5.3 • Suitable replacement for ceramic composition resistors, which are required in most applications. • Maximum permissible surge voltage: 15KV • Typical 1.2/50us pulse load: 90000W 	2W	33R ~ 22K	±5%, ±10%, ±20%	P1-P2
	<p>CM Carbon Film MELF Resistor</p> <ul style="list-style-type: none"> • SMD enabled structure • Excellent solderability termination 	1/6W ~ 1/2W	0R ~ 10M	± 5%	P3-P6
	<p>CSM Current Sense MELF Resistor</p> <ul style="list-style-type: none"> • High power handling with superior reliability and stability • Conformal multi-layer coating against humidity • SMD enabled structure with excellent solderability • HeatSinker™ technology for better heat dissipation • Typical temperature coefficient: 50ppm ~ 600ppm 	1/4W ~ 3W	10mR ~ 510mR	± 1% ~ 5%	P7-P10
	<p>CSR Current Sense Resistor</p> <ul style="list-style-type: none"> • Offers better reliability than regular low-ohm resistors using our proprietary HeatSinker™ technology • Lead-free tin plated deoxygenized copper wire provides stable value of resistor during operation. • Flame-proof coating available • Typical temperature coefficient: 100ppm ~ 300ppm 	1/4W ~ 5W	68mR ~ 510mR	± 1% ~ 5%	P11-P14
	<p>EFP Enhanced Film Power MELF Resistor</p> <ul style="list-style-type: none"> • High power handling • Superior reliability and stability • SMD enabled structure with excellent solderability • Typical temperature coefficient: 200ppm ~ 800ppm 	1/2W ~ 5W	0R ~ 10M	± 0.5% ~ 5%	P15-P18
	<p>EFR Enhanced Film Fixed Resistor</p> <ul style="list-style-type: none"> • Flameproof multi-layer coating meets UL 94 V-0 • Flameproof feature meets overload test UL 1412 • High power handling in small size • Typical temperature coefficient: 50ppm ~ 500ppm 	1/2W ~ 5W	1R ~ 1M	± 1%, ± 2%, ± 5%	P19-P22

* All products are RoHS/REACH compliant unless otherwise specified.







* NOTE 1: patent pending

Resistor	Key Features	Power Rating	Ohm Range	Tolerance	Page
	ESM ESD Surge Absorber MELF <ul style="list-style-type: none"> Protects the circuit by sparking over the porous layer when surge exceeds the spark-over voltage Patented construction with reduced costs High insulation resistance, low capacitance, and fast response time 	$\left\{ \begin{array}{l} 80A @2/10\mu s \\ 60A @8/20\mu s \end{array} \right\}$ Surge Current Capacity	$\left\{ \begin{array}{l} 1300V \\ DC \\ Spark-Over \\ Voltage \end{array} \right\}$	± 30%	P23-P26
	FGE Fusible Resistor <ul style="list-style-type: none"> Flameproof multi-layer coating meets UL 94 V-0 Flameproof feature meets overload test UL 1412 Color code per MIL & EIA standards Special tin-plated electrolytic copper lead wire Typical fusing condition - (a) Standard Type: Fuses within 10 sec. at 5W ~ 6.25W (b) Power Types: Fuses within 60 sec. at 8W ~ 20W 	1/4W ~ 2W	2R2 ~ 15K	± 5%	P27-P29
	FGE26C Fusible Resistor Constant Current <ul style="list-style-type: none"> Delay fusing within 60 sec. in case of excessive current Constant current fusing type Fuses at low magnification of power rating (5.2 times) Flameproof multi-layer coating meets UL 94 V-0 Flameproof feature meets overload test UL 1412 Special tin-plated electrolytic copper lead wire Fuses within 10 sec. at 1.6W 	1/4W	0R1 ~ 0R91	±5% ~ 10%	P31-P36
	FM Fusible MELF Resistor <ul style="list-style-type: none"> SMD enabled structure Excellent solderability termination Fuses within 10 sec. at 9.8W ~ 10.5W 	1/3W ~ 1/2W	2R2 ~ 10K	± 5%	P37-P38
	HDR High Voltage Discharge Resistor <ul style="list-style-type: none"> Excellent anti-surge characteristic Suitable for medium to high working voltage Flameproof coating available Typical 1.2/50us pulse load: 100W ~ 990W 	1/4W ~ 2W	100K ~ 56M	± 5%	P39-P42
	HFT High Frequency Terminator Resistor <ul style="list-style-type: none"> SMD enabled structure Superior frequency response Excellent solderability termination 	1/4W ~ 1/3W	25R ~ 75R	± 0.1% ~ 1%	P43-P48

* All products are RoHS/REACH compliant unless otherwise specified.

Resistor	Key Features	Power Rating	Ohm Range	Tolerance	Page
	HVM High Voltage MELF Resistor <ul style="list-style-type: none"> • Handles much higher working voltage than general purpose resistors do • Pure tin-plated termination for excellent solderability • SMD enabled structure • Anti-surge feature available • Maximum working voltage: 600V DC ~ 8400V DC 	1/6W ~ 3W	56K ~ 68M	± 1% ~ 5%	P49-P52
	HVR High Voltage Resistor <ul style="list-style-type: none"> • Special conductive film withstands high voltage • Maximum working voltage far over that of general-purpose resistors • Suitable for applications such as TV's, high voltage power supply, and high voltage detection. • Entire series is VDE0860 (EN60065) approved under license number 40011593 • Maximum working voltage: 1.6KV DC ~ 12KV DC • Typical temperature coefficient: 200ppm ~ 800ppm 	1/4W ~ 3W	91K ~ 100M	± 1% ± 5%	P53-P55
	HVR High Voltage Resistor (High Power) <ul style="list-style-type: none"> • Special conductive film withstands voltage far over the maximum working voltage of general-purpose resistors. • Suitable for applications such as TV's, high voltage power supply, and high voltage detection. • Maximum working voltage: 35KV DC • Typical temperature coefficient: 800ppm 	10W ~ 15W	100K ~ 100M	± 1%, ± 5%	P57-P58
	IG Ignition Fixed Resistor <ul style="list-style-type: none"> • Special coating technique to ensure fast ignition • Color code per MIL & EIA standards • Special conductive film to fuse at high temperature • Auto cut-off after fusing/no sustaining fire hazard • Special tin-plated electrolytic copper lead wire for optimal ease of soldering and mounting 	1/6W ~ 1/3W	1R ~ 150R	± 5%	P59-P61
	M-Series Metal Film Fixed Resistor <ul style="list-style-type: none"> • Conformal multi-layer coating • Color code per MIL & EIA standards • Special tin-plated electrolytic copper lead wire 	1/6W ~ 3W	0R1 ~ 10M	± 0.1% ~ 5%	P63-P72
	MM(P) Metal Film MELF Resistor (Pulse Withstanding) <ul style="list-style-type: none"> • SMD enabled structure • Excellent solderability termination • Enhanced pulse withstanding capability • Maximum 1.2/50us pulse load: 1000W ~ 1600W • Typical temperature coefficient: 50ppm, 100ppm 	1/6W ~ 1/2W	0R1 ~ 330K	± 1%, ± 2%, ± 5%	P73-P75

* All products are RoHS/REACH compliant unless otherwise specified.

Resistor	Key Features	Power Rating	Ohm Range	Tolerance	Page
	MM Metal Film MELF Resistor <ul style="list-style-type: none"> SMD enabled structure Excellent solderability termination Typical 1.2/50us pulse load: 32W ~ 70W Typical temperature coefficient: 25ppm ~ 100ppm 	1/6W ~ 1/2W	0R51 ~ 10M	± 1%, ± 2%, ± 5%	P77-P80
	MMP Metal Film MELF Precision Resistor <ul style="list-style-type: none"> SMD enabled structure Excellent solderability termination Typical 1.2/50us pulse load: 32W ~ 70W Typical temperature coefficient: 5ppm ~ 50ppm 	1/6W ~ 1/2W	10R ~ 1M	± 0.1%, ± 0.25%, ± 0.5%	P81-P85
	MO Metal Oxide Film Fixed Resistor <ul style="list-style-type: none"> Flameproof multi-layer coating meets UL 94 V-0 Flameproof feature meets overload test UL 1412 Solvent resistant Special tin-plated electrolytic copper lead wire 	1/2W ~ 10W	0R1 ~ 330K	± 5%	P87-P94
	MP Metal Film Precision Resistor <ul style="list-style-type: none"> Conformal multi-layer coating Color code per MIL & EIA standards Special tin-plated electrolytic copper lead wire Typical temperature coefficient: 10ppm ~ 50ppm 	1/6W ~ 1/2W	10R ~ 1M	± 0.05% ~ 0.5%	P95-P98
	MSD Pulse Safety Resistor <ul style="list-style-type: none"> Special composite film on high grade ceramic substrate Flameproof coating meets UL 94 V-0 and overload test UL 1412 Excellent anti-surge capability. Typical 1.2/50us pulse load: 140W ~ 4500W Absorbs pulse from city power line, direct crossing or inductive coupling and protects electric equipment or parts from accidental shock Low-cost alternative to wire-wound resistors 	1/4W ~ 6W	0R1 ~ 1M	± 0.1% ~ 5%	P99-P106
	MVR Medium Voltage Resistor <ul style="list-style-type: none"> Higher working voltage with improved reliability Proprietary conductive film Especially suitable for SMPS & lighting devices Low-cost alternative to metal-glazed resistors Maximum working voltage: 550V DC ~ 7KV DC Typical temperature coefficient: 100ppm ~ 800ppm 	1/4W ~ 2W	47K ~ 100M	± 0.1% ~ ± 5%	P107-P109



* All products are RoHS/REACH compliant unless otherwise specified.

Resistor	Key Features	Power Rating	Ohm Range	Tolerance	Page
	NFR Non Flammable Carbon Film Resistor <ul style="list-style-type: none"> Conformal multi-layer non-flammable coating Color code per MIL & EIA standards Special tin-plated electrolytic copper lead wire 	1/6W ~ 2W	1R ~ 10M	± 5%	P111-P114
	NL Non-inductive Resistor <ul style="list-style-type: none"> Proprietary conductive film Required by operating environment that demands consistent performance Performs with virtually no inductance Typical temperature coefficient: 100ppm ~ 300ppm 	1/2W ~ 20W	0R1 ~ 47K	± 1% ± 5%	P115-P116
	PMA Professional Metal Film Axial Resistor <ul style="list-style-type: none"> Conformal multi-layer coating Excellent stability and better power handling Typical temperature coefficient: 5ppm ~ 100ppm 	1/4W ~ 1.2W	1R ~ 4M7	± 0.1% ~ 5%	P117-P120
	PPR Pulse Protective Resistor <ul style="list-style-type: none"> Application: high-frequency, sharp-impulse circuits. Protects active components in missile detonators, triac switching circuits, etc. Offers better performance than carbon composition resistor. No "sintering effect" caused by high surge that greatly decreases resistance value. Conformal multi-layer non-flammable coating Maximum permissible surge voltage: 5KV ~ 20KV Typical 1.2/50us pulse load: 75W ~ 1300W 	1/6W ~ 2W	2R2 ~ 4M7	± 5%	P121-P124
	PSR Power Sink Resistor <ul style="list-style-type: none"> Designed to replace cement resistors Auto insertion feasible Enhanced conductive film absorbs pulse noise Superior-grade ceramic core dissipates heat efficiently Flameproof multi-layer coating meets UL 94 V-0 & overload test UL 1412 Maximum permissible surge voltage: 20KV Typical 1.2/50us pulse load: 1700W 	6W	1R ~ 4M7	± 5%	P125-P126
	PWR Power Metal Film Resistor <ul style="list-style-type: none"> Conformal multi-layer coating Color code per MIL & EIA standards Special tin-plated electrolytic copper lead wire Typical temperature coefficient: 250ppm 	0.6W ~ 2W	0R22 ~ 1M	± 5%	P127-P130



* All products are RoHS/REACH compliant unless otherwise specified.

Resistor	Key Features	Power Rating	Ohm Range	Tolerance	Page
	R-Series Carbon Film Power Resistor <ul style="list-style-type: none"> • Conformal multi-layer coating • Color code per MIL & EIA standards • Special tin-plated electrolytic copper lead wire • Non-flammable coating option available 	1/6W ~ 3W	1R ~ 10M	± 5%	P131-P138
	SCP Short Circuit Protection Resistor <ul style="list-style-type: none"> • Advanced multi-functional design • Cut-off on overload or accidental short circuit • Transient withstanding for power-line coupling • Flameproof multi-layer coating meets UL 94 V-0 and overload test UL 1412 • Possible alternative to wire-wound resistors • Maximum overload voltage: 600V ~ 700V • Fuses within 60 sec. at 12W ~ 30W 	1/2W ~ 3W	2R2 ~ 10K	± 5%	P139-P141
	SFP Stabilized Film Power MELF Resistor <ul style="list-style-type: none"> • Low temperature coefficient and tolerances • Excellent stability • Superior power handling • Typical temperature coefficient: 50ppm ~ 200ppm 	1/2W ~ 3W	0R5 ~ 10M	± 0.5% ~ 5%	P143-P146
	SGS Spark-Gap Surge Absorber <ul style="list-style-type: none"> • Low-cost patented construction (EP 09000962.2) • No light-dark effect • Low capacitance / short response time / fast ignition • Response time: ≤1ns 	$\left\{ \begin{array}{l} 80A @2/10\mu s \\ 60A @8/20\mu s \end{array} \right\}$ Surge Current Capacity	1550V ~ 3300V DC Spark-Over Voltage	± 30%	P147-P150
	SL Slug Resistor <ul style="list-style-type: none"> • Specially treated metal caps withstand abrasions, impacts, and corrosions, so as to reduce contact resistance during operation. conductive film is enhanced to withstand abrasions, impacts, and corrosions as well. Suitable for clip-in (embedded) application like switches with neon indicators, neon/LED modules, LED display array, etc. 	1/6W ~ 1/2W	1R ~ 9M1	± 5% ~ 10%	P151-P152
	SLC Slug Resistor Center Coated <ul style="list-style-type: none"> • Specially treated metal caps withstand abrasions, impacts, and corrosions, so as to reduce contact resistance during operation. conductive film is enhanced to withstand abrasions, impacts, and corrosions as well. Suitable for clip-in (embedded) application like switches with neon indicators, neon/LED modules, LED display array, etc. 	1/6W ~ 1/2W	1R ~ 9M1	± 5% ~ 10%	P153-P154

* All products are RoHS/REACH compliant unless otherwise specified.

Resistor	Key Features	Power Rating	Ohm Range	Tolerance	Page
	<p>SM Stabilized Metal Film MELF Resistor</p> <ul style="list-style-type: none"> • Conformal coating against humidity • Excellent solderability termination • Typical 1.2/50us pulse load: 32W ~ 70W • Typical temperature coefficient: 25ppm ~ 100ppm 	1/6W ~ 1/2W	0R51 ~ 10M	± 1% ~ 5%	P155-P158
	<p>SRM Surge Resistant MELF Resistor</p> <ul style="list-style-type: none"> • Miniaturized MELF design handles high power • Special conductive film enhances anti-surge capability • Absorbs harmful surge which damages precious devices or components • SMD-enabled alternative to carbon composition resistors • Maximum permissible surge voltage: 2KV ~ 10KV • Typical 1.2/50us pulse load: 60W ~ 6000W 	1/4W ~ 3W	0R1 ~ 1M	± 1% ~ 5%	P159-P164
	<p>SRS Spark Noise Suppression Slug Resistor</p> <p>Dedicatedly designed for high-voltage spark ignition systems. Proprietary conductive film withstands high-voltage surge impacts with long-term stability. One of few sources in the world capable of manufacturing such type of resistor. Maximum surge load: 20KV/10ns, 35KV/20ns, 50KV/20ns, 50KV/30ns Note: to be replaced by ISC/ISW series effectively March 2015.</p>	1/2W ~ 4W	10R ~ 33K	± 5% ~ 20%	P165-P166
	<p>SSR Surge Safety Resistor</p> <ul style="list-style-type: none"> • Designed to replace carbon or ceramic composition resistor • Absorbs harmful surge energy, so to prevent hazard of fire and circuit damage caused by surge energy with a flame proof coating • High-surge applications: fuel ignition systems, power charging/ discharging circuits, TV sets, etc. • Maximum permissible surge voltage: 7.5KV ~ 35KV • Typical 1.2/50us pulse load: 450W ~ 17000W 	1/6W ~ 5W	10R ~ 330K	± 5%	P167-P172
	<p>SWA Anti-Surge Wirewound Resistor</p> <ul style="list-style-type: none"> • Flameproof multi-layer coating meets UL 94 V-0 • Flameproof feature meets overload test UL1412 • SWA series can be adopted for high surge applications such as high rush current protection for power capacitor, motor start-up protection, car & motorcycle engine ignition, etc. to absorb harmful surge energy and prevent hazard of circuit damage caused by surge impact. • Enhanced weld spot is reliable against surge impact • Special tin-plated electrolytic copper lead wire • Typical 1.2/50us pulse load: 12000W ~ 36000W** 	1W ~ 3W	0R1 ~ 1K5	± 5%	P173-P175
	<p>SWM Anti-Surge Wirewound MELF Resistor</p> <ul style="list-style-type: none"> • SMD enabled structure • Flameproof multi-layer coating meets UL 94 V-0 • Flameproof feature meets overload test UL 1412 • SWM series can be adopted for high surge applications such as high rush current protection for power capacitor, motor start-up protection, car & motorcycle engine ignition, etc. to absorb harmful surge energy and prevent hazard of circuit damage caused by surge impact. • Enhanced weld spot is reliable against surge impact • Typical 1.2/50us pulse load: 8000W ~ 32000W** 	1W ~ 4W	0R1 ~ 1K5	± 5%	P177-P180

* All products are RoHS/REACH compliant unless otherwise specified.

Resistor	Key Features	Power Rating	Ohm Range	Tolerance	Page
	WA Wirewound Resistors <ul style="list-style-type: none"> • Flameproof multi-layer coating meets UL 94 V-0 • Flameproof feature meets overload test UL 1412 • Color code per MIL & EIA standards • Special tin-plated electrolytic copper lead wire 	1/2W ~ 8W	0R1 ~ 3K3	± 2% ± 5%	P181-P186
	ZMM Zero Ohm Metal Film MELF Resistor <ul style="list-style-type: none"> • SMD enable structure • Excellent solderability termination • Stable metal film construction 	2A ~ 4A { Maximum Current }	< 20mR	N/A	P187-P188
	ZOM Zero Ohm Metal Film Resistor <ul style="list-style-type: none"> • Conformal multi-layer coating against humidity • Very low resistance • Stable metal film construction • Special tin-plated deoxygenized copper wire for resistance stabilization during operation 	3A ~ 5A { Maximum Current }	< 10mR	N/A	P189-P190

* All products are RoHS/REACH compliant unless otherwise specified.

Detail information of following products can be expected in late 2014/early 2015. Please contact us for more information.

- Size 0102 Metal Film MELF Resistor
- ISC - Ignition Noise Suppression Resistor (Film/Ceramic Composite Type): designed for high-voltage spark ignition systems
- ISW - Ignition Noise Suppression Resistor (Wirewound Type): designed for high-voltage spark ignition systems
- MVM - Medium Voltage MELF Resistor

**~ To be your valuable partner in the
component industry through constant product
innovation and customer satisfaction~**

~ Firstohm, where OHM comes FIRST ~

Application Reference Table

Product Datasheets

C3 - Composite Film-Type Ceramic Composition Resistor

Quality • Reliability
Cost-Down via Technology

C3

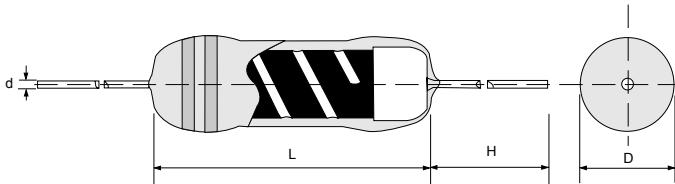

Features

- Innovative and cost-effective C3 technology
- Conforms to ANSI/AAMI norm EC53:1995/(R)2008 5.5.3
- Suitable replacement for ceramic composition resistors, which are required in most applications.
- Products meet RoHS requirements and do not contain substances of very high concern identified by European Chemicals Agency

DIMENSIONS

Type	Body Length (L, mm)	Body Diameter (D, mm)	Lead Wire Length (H, mm)	Lead Wire Diameter (d, mm)	Net Weight Per 1000 Pcs
C3200	15.5 ± 1.0	5.0 ± 0.5	30 ± 3.0	0.80 ± 0.03	1150 Grams

GENERAL SPECIFICATIONS

Type	Power Rating (at 70°C)	Maximum Working Voltage	Maximum Permissible Surge Voltage	Minimum Resistance	Maximum Resistance	Resistance Tolerance	Available Resistance Values
C3200	2W	300V	15kV	33Ω	22KΩ	± 5%, ± 10%, ± 20%	E-6 / E-12 / E-24

PART NUMBER

Example: C3200K1K00TKZTB500

C3200	K	1K00	TKZ	TB500
Type	Tolerance	Resistance	TCR	Packaging
	J (5%) K (10%) M (20%)	1KΩ 4-character code containing - 3 significant digits 1 letter multiplier MULTIPLIER R = 1 K = 10 ³ M = 10 ⁶ G = 10 ⁹	3-character code TKZ = Default Product Temperature Coefficient. Information of typical product temperature coefficient can be found in the Technical Summary section of the datasheet.	5-character code TB = Tape Box 500 pieces per box

C3200

SURGE PERFORMANCE

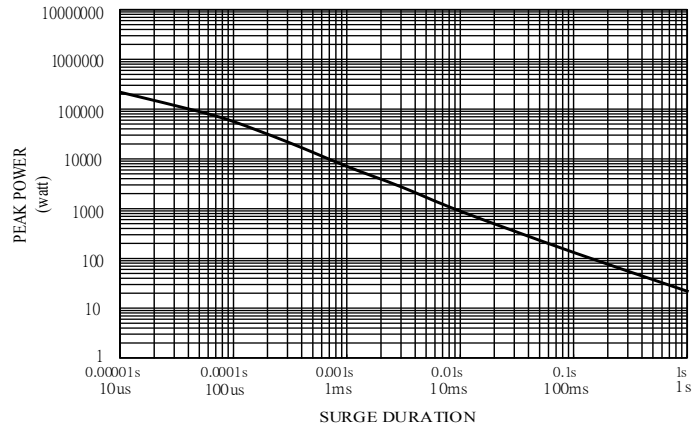

TECHNICAL SUMMARY

Characteristics	Limits
Power Derating, Linear	100% at < 70°C, down to zero at 200°C
Dielectric Withstanding Voltage, VAC or DC	800
Temperature Coefficient, PPM / °C	-3000 (Typical)
Operating Temperature Range, °C	-55 ~ +200
Insulation Resistance, MΩ	>10 ⁴

PERFORMANCE SPECIFICATIONS

Characteristics	Test Conditions	Limits
Short Time Over Load	IEC 60115-1 4.13 5 seconds 2.5x rated voltage (not over 2x max working voltage)	±2%
Load Life In Humidity	IEC 60115-1 4.24 56 days rated load at (40±2)°C and (93±3)% relative humidity	±5%
Load Life 1,000 hours	IEC 60115-1 4.25.1 Rated load with 1.5 hours ON, 0.5 hours OFF, at (70±2)°C	±5%
Resistance To Soldering Heat	IEC 60115-1 4.18.2 Leads immersed till 3mm from the body in (260±5)°C solder for 10±1 seconds	±2%
Solderability	IEC 60115-1 4.17.2 Solder area covered after (235±3)°C / (2±0.2) seconds with flux applied	90% Min.
Vibration	IEC 60115-1 4.22 Six hours in each parallel and axial direction with a simple harmonic motion having an amplitude of 0.75mm and 10 to 500 Hz.	±2%
Thermal Endurance	IEC 60115-1 4.25.3 1000 hours at 200°C without load	±5%
Thermal Shock	IEC 60115-1 4.19 -55°C 30minutes, +155°C 30minutes, 5 cycles	±3%
Surge Test	Surge voltage = $\sqrt{120,000 \times P \times R}$ DC P is power rating, R is resistance value, surge voltage is not more than listed at right. Surge duration = 500ns Period = 2 sec Number of surges = 20,000	C3200 15KV ±5%

Quality • Reliability
Cost-Down via Technology

CM

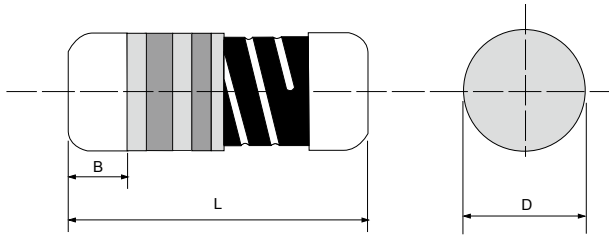

Specifications Per

- IEC 60115-1, IEC 60115-2
- MIL-R-226848

Features

- SMD enabled structure
- Excellent solderability termination
- Products meet RoHS requirements and do not contain substances of very high concern identified by European Chemicals Agency

DIMENSIONS

Type	Body Length (L, mm)	Body Diameter (D, mm)	Soldering Spot (B, mm)	Net Weight Per 1000 pcs
CM16	3.52 ± 0.08	1.35 ± 0.1	0.6 Min.	17 grams
CM204	3.52 ± 0.08	1.35 ± 0.1	0.6 Min.	17 grams
CM207	5.90 ± 0.20	2.20 ± 0.1	1.0 Min.	66 grams
CM52	5.90 ± 0.20	2.20 ± 0.1	1.0 Min.	66 grams

GENERAL SPECIFICATIONS

Type	Power Rating (at 70°C)	Maximum Working Voltage	Maximum Overload Voltage	Minimum Resistance	Maximum Resistance	Resistance Tolerance	Available Resistance Values
CM16	1/6W	200V	300V	0, 0.1Ω	1MΩ	±5%	E-24
CM204	1/4W	200V	300V	0, 0.1Ω	1MΩ	±5%	E-24
CM207	1/3W	300V	600V	0, 0.1Ω	10MΩ	±5%	E-24
CM52	1/2W	350V	600V	0, 0.1Ω	10MΩ	±5%	E-24

For zero ohm jumper, please see ZMM series. For 1 m~100mΩ please see CSM series.
Special sizes, values, and specifications not listed available on special order.

POWER DERATING CURVE

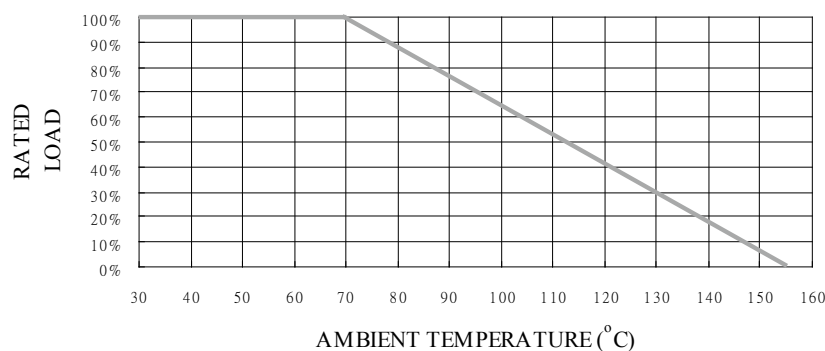

TECHNICAL SUMMARY

Characteristics	Limits			
Dielectric Withstanding Voltage, VAC or DC	CM16,CM204: 200, CM207,CM52: 500			
Temperature Coefficient, PPM / °C	CM16 & CM204		CM207 & CM52	
	1Ω~33K	±300	1Ω~33K	±300
	33K~330K	- 500	33K~330K	- 500
	330K~470K	- 700	330K~470K	- 700
	470K~910K	-1000	470K-1M	-1000
Over 910K	-1500	Over 1M	-1500	
Operating Temperature Range, °C	-55 ~ +155			
Insulation Resistance, MΩ	>10 ⁴			
Tin Whisker (JESD201 Temperature Cycling & High Temp. /Humidity Storage), μm	<5			

PART NUMBER

Example: CM204J10K0TKZTR3K0

CM204	J	10K0	TKZ	TR3K0
Type	Tolerance	Resistance	TCR	Packaging
	J (5%)	10KΩ 4-character code containing - 3 significant digits 1 letter multiplier <u>MULTIPLIER</u> R = 1 K = 10 ³ M = 10 ⁶ G = 10 ⁹	3-character code TKZ = Default Product Temperature Coefficient. Information of typical product temperature coefficient can be found in the Technical Summary section of the datasheet.	5-character code TR = Tape Reel (pieces per reel) <u>CM16/CM204</u> 3K0 = 3,000 6K0 = 6,000* 10K = 10,000* <u>CM207/CM52</u> 2K0 = 2,000 6K0 = 6,000* 10K = 10,000*

*upon request

COVER TAPE PEELING SPECIFICATION

Recommended peeling force:

CM16, CM204, CM207, CM52: 50±5gf

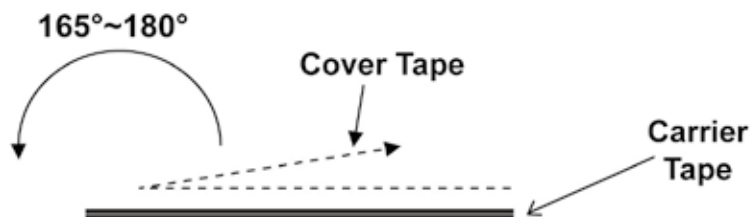

■ PERFORMANCE SPECIFICATIONS

Characteristics	Test Conditions	Limits
Short Time Overload	IEC 60115-1 4.13 5 seconds 2.5x rated voltage (not over max. overload voltage)	± 1%
Load Life In Humidity	IEC 60115-1 4.24 56 days rated load at (40±2)°C and (93±3)% relative humidity	± 5%
Load Life 1,000 hours	IEC 60115-1 4.25.1 Rated load with 1.5 hours ON, 0.5 hours OFF, at (70±2)°C	± 3%
Periodic Electric Overload	IEC 60115-1 4.39 3.9x rated voltage (not over max. overload voltage) with 0.1s ON, 2.5s OFF for 1,000 cycles	± 2%
Resistance To Soldering Heat	IEC 60115-1 4.18.2 Dip the resistor into a solder bath measured (260±5)°C and hold it for 10±1 seconds	± 1%
Solderability	IEC 60115-1 4.17.2 Solder area covered after (230±3)°C/(2±0.2) seconds with flux applied	95% Min.
Vibration	IEC 60115-1 4.22 Six hours in each parallel and axial direction with a simple harmonic motion having an amplitude of 1.52mm and 10 to 2,000 Hz.	± 1%
Thermal Endurance	IEC 60115-1 4.25.3 1000 hours at 155°C without load	± 1%
Thermal Shock	IEC 60115-1 4.19 -55°C 30minutes, +155°C 30minutes, 5 cycles	± 1%
Single pulse high voltage overload	IEC 60115-1 4.27 10 pulses of 10/700µs at 10x rated voltage (not over max. overload voltage) with interval of 60 sec.	± 2%
Electrostatic discharge (Human body model)	IEC 60115-1 4.38 3 positive & 3 negative discharges with 4KV source	± 5%
Climatic test	IEC 60115-1 4.23 4.23.2 - dry heat: 16 hours 155°C 4.23.3 - damp heat: 24 hours 55°C with 95% relative humidity 4.23.4 - cold: 2 hours -55°C 4.23.5 - negative air pressure: 2 hour 8.5KPa at (25±10)°C 4.23.6 - damp heat cyclic: 5 days 55°C with 95% relative humidity 4.23.7 - DC load: rated voltage at -55°C and 155°C each 1 Min.	± 2%
Bending test	IEC 60115-1 4.33 Pressing depth 2mm, 3 times	± 0.25%
Flammability	IEC 60115-1 4.35 Needle flame test 10s	No burning after 30s

CM Carbon Film MELF Resistor

Quality • Reliability
Cost-Down via Technology

■ SUGGESTED PAD LAYOUT

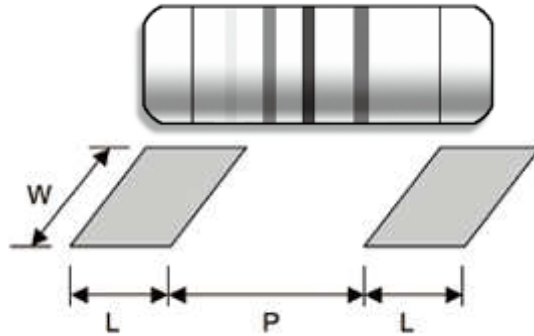

CM

Type	Soldering Mode	Pad Length (L, mm, Min.)	Pad Spacing (P, mm)	Pad Width (W, mm, Min.)
CM16	Reflow	1.0	2.0 ± 0.2	1.6
	Wave	1.2	2.0 ± 0.2	1.6
CM204	Reflow	1.0	2.0 ± 0.2	1.6
	Wave	1.2	2.0 ± 0.2	1.6
CM207	Reflow	2.0	3.0 ± 0.3	3.0
	Wave	2.5	3.0 ± 0.3	3.0
CM52	Reflow	2.0	3.0 ± 0.3	3.0
	Wave	2.5	3.0 ± 0.3	3.0

For better heat dissipation / lower heat resistance, increase W & L.

Quality • Reliability
Cost-Down via Technology

CSM

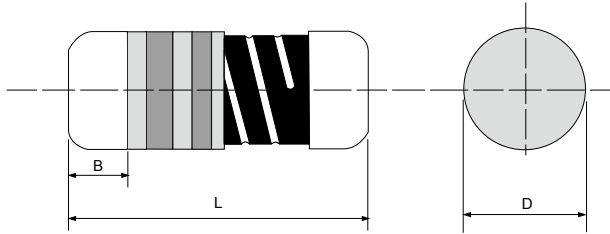

Specifications Per

• IEC 60115-1

Features

- High power handling with superior reliability and stability
- Conformal multi-layer coating against humidity
- SMD enabled structure with excellent solderability
- HeatSinker™ technology for better heat dissipation
- Products meet RoHS requirements and do not contain substances of very high concern identified by European Chemicals Agency

DIMENSIONS

Type	Body Length (L, mm)	Body Diameter (D, mm)	Soldering Spot (B, mm)	Net Weight Per 1000 pcs
CSM204	3.52 ± 0.08	1.35 ± 0.1	0.6 Min.	17 grams
CSM52	5.90 ± 0.20	2.20 ± 0.1	1.0 Min.	66 grams
CSM101	5.90 ± 0.20	2.20 ± 0.1	1.0 Min.	66 grams
CSM201	8.50 ± 1.00	3.00 ± 0.2	1.3 Min.	186 grams
CSM301	10.5 ± 1.00	4.00 ± 0.5	1.6 Min.	446 grams

GENERAL SPECIFICATIONS

Type	Power Rating (at 70°C)	Maximum Working Voltage	Maximum Overload Voltage	Minimum Resistance	Maximum Resistance	Resistance Tolerance	Available Resistance Values
CSM204	1/4W	200V	400V	10mΩ	510mΩ	±1%~5%	E-24 / E-96
CSM52	1/2W	250V	500V	10mΩ	510mΩ	±1%~5%	E-24 / E-96
CSM101	1W	250V	500V	10mΩ	510mΩ	±1%~5%	E-24 / E-96
CSM201	2W	300V	600V	10mΩ	510mΩ	±1%~5%	E-24 / E-96
CSM301	3W	350V	700V	10mΩ	510mΩ	±1%~5%	E-24 / E-96

Special sizes, values, and specifications not listed available on special order

POWER DERATING CURVE

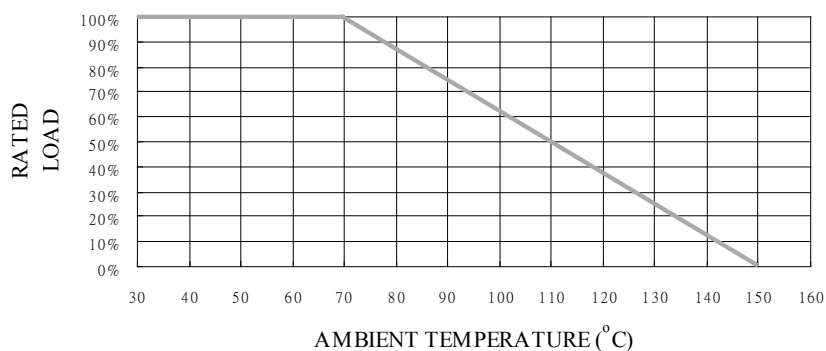

■ TECHNICAL SUMMARY

Characteristics	Limits
Dielectric Withstanding Voltage, VAC or VDC	CSM204: 200 CSM52, CSM101: 500 CSM201, CSM301: 700
Temperature Coefficient, PPM / °C	±50, ±100, ±200, ±300, ±600
Operating Temperature Range, °C	-55 ~ +150
Insulation Resistance, MΩ	>10 ⁴
Tin Whisker (JESD201 Temperature Cycling & High Temp. /Humidity Storage), μm	<5
Power Derating, linear	100% at 70 °C, down to zero at 150 °C

* Not applicable to all resistance values. Please check with us regarding the PPM of specific resistance value(s).

■ PART NUMBER

Example: CSM201JR510TKZTR2K5

CSM201	J	R510	TKZ	TR2K5
Type	Tolerance*	Resistance	TCR	Packaging
	F (1%) G (2%) J (5%)	0.51Ω 4-character code containing - 3 significant digits 1 letter multiplier <u>MULTIPLIER</u> R = 1 K = 10 ³ M = 10 ⁶ G = 10 ⁹	3-character code TKZ = Default Product Temperature Coefficient. Information of typical product temperature coefficient can be found in the Technical Summary section of the datasheet.**	5-character code TR = Tape Reel (pieces per reel) CSM204 3K0 = 3,000 6K0 = 6,000*** 10K = 10,000*** <u>CSM52/CSM101</u> 2K0 = 2,000 6K0 = 6,000*** 10K = 10,000*** <u>CSM201</u> 2K5 = 2,500 <u>CSM301</u> 2K0 = 2,000

* Listed values may not be applicable to all resistance values. Please check with us before placing order.

** For the availabilities of non-default temperature coefficient, please check with us. Reference for TCR letter codes can be found in section (4) of Part Number Construction in the Appendices.

*** upon request

■ COVER TAPE PEELING SPECIFICATION

Recommended peeling force:

CSM204, CSM52, CSM101: 50±5gf CSM201, CSM301: 70±10gf

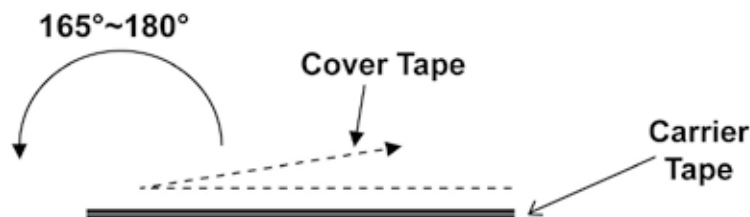

■ PERFORMANCE SPECIFICATIONS

Characteristics	Test Conditions	Limits
Short Time Overload	IEC 60115-1 4.13 2 seconds 2.5x rated voltage (not over max. overload voltage)	±1%, 2%: ±0.75% ±5%: ±2%
Load Life 1,000 hours	IEC 60115-1 4.25.1 Rated load with 1.5 hours ON, 0.5 hours OFF, at (70±2)°C	±3%
Load Life In Humidity	IEC 60115-1 4.24 56 days rated load at 40°C and (93±3)% relative humidity	±3%
Periodic Electric Overload	IEC 60115-1 4.39 3.9x rated voltage (not over max. overload voltage) with 0.1s ON, 2.5s OFF for 1,000 cycles	±5%
Resistance To Soldering Heat	IEC 60115-1 4.18.2 Dip the resistor into a solder bath measured (260±5)°C and hold it for 10±1 seconds	±1%
Solderability	IEC 60115-1 4.17.2 Solder area covered after (235±3)°C/(2±0.2) seconds with flux applied	95% min
Thermal Endurance	IEC 60115-1 4.25.3 1000 hours at 150°C without load	±1%
Thermal Shock	IEC 60115-1 4.19 -55°C 30minutes, +150°C 30minutes, 5 cycles	±2%
Single pulse high voltage overload	IEC 60115-1 4.27 10 pulses of 10/700µs at 10x rated voltage (not over max. overload voltage) with interval of 60 sec.	± 2%
Electrostatic discharge (Human body model)	IEC 60115-1 4.38 3 positive & 3 negative discharges with 4KV source	± 5%
Climatic test	IEC 60115-1 4.23 4.23.2 - dry heat: 16 hours 150°C 4.23.3 - damp heat: 24 hours 55°C with 95% relative humidity 4.23.4 - cold: 2 hours -55°C 4.23.5 - negative air pressure: 2 hour 8.5kPa at (25±10)°C 4.23.6 - damp heat cyclic: 5 days 55°C with 95% relative humidity 4.23.7 - DC load: rated voltage at -55°C and 150°C each 1 Min.	± 2%
Vibration	IEC 60115-1 4.22 Six hours in each parallel and axial direction with a simple harmonic motion having an amplitude of 1.52mm and 10 to 2,000 Hz.	±1%
Bending test	IEC 60115-1 4.33 Pressing depth 2mm, 3 times	± 0.5%
Flammability	IEC 60115-1 4.35 Needle flame test 10s	No burning after 30s

Quality • Reliability
Cost-Down via Technology

CSM

■ SUGGESTED PAD LAYOUT

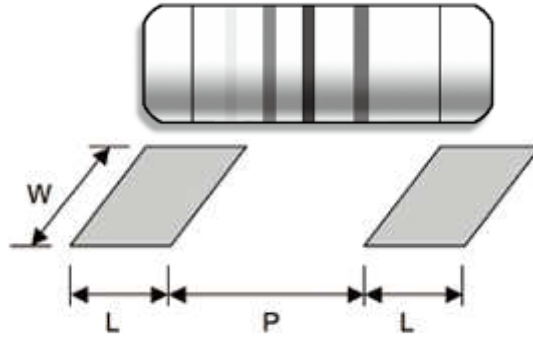

Type	Soldering Mode	Pad Length (L, mm, Min.)	Pad Spacing (P, mm)	Pad Width (W, mm, Min.)
CSM204	Reflow	1.0	2.0 ± 0.2	1.6
	Wave	1.2	2.0 ± 0.2	1.6
CSM52	Reflow	2.0	3.0 ± 0.3	3.0
	Wave	2.5	3.0 ± 0.3	3.0
CSM101	Reflow	2.0	3.0 ± 0.3	3.0
	Wave	2.5	3.0 ± 0.3	3.0
CSM201	Reflow	3.0	4.9 ± 0.3	3.7
	Wave	3.5	4.8 ± 0.3	4.0
CSM301	Reflow (Not recommended)	4.0	6.2 ± 0.4	4.5
	Wave	4.5	6.0 ± 0.4	5.0

For better heat dissipation / lower heat resistance, increase W & L.

■ SUGGESTED PAD LAYOUT FOR KELVIN (4-WIRE) SENSING

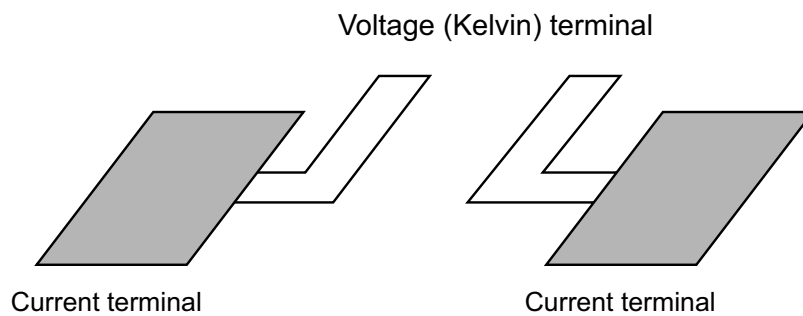

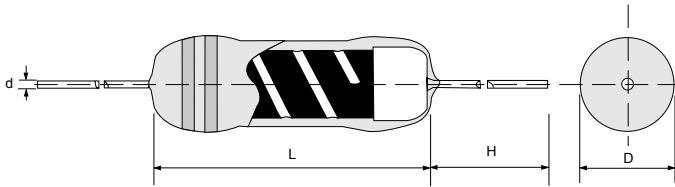

Features

Using our proprietary HeatSink™ technology, CSR series offers a better reliability than regular low-ohm resistors. Lead-free tin plated deoxygenized copper wire provides stable value of resistor during operation.

Flame-proof coating available.

- Products meet RoHS requirements and do not contain substances of very high concern identified by European Chemicals Agency

DIMENSIONS

Type	Body Length (L, mm)	Body Diameter (D, mm)	Lead Wire Length (H, mm)	Lead Wire Diameter (d, mm)	Net Weight Per 1000Pcs
CSR20	3.20 ± 1.0	1.9 ± 0.2	28 ± 3.0	0.45 ± 0.02	145 Grams
CSR25	6.50 ± 1.0	2.4 ± 0.2	26 ± 3.0	0.55 ± 0.03	220 Grams
CSR207	6.50 ± 1.0	2.4 ± 0.2	26 ± 3.0	0.55 ± 0.03	220 Grams
CSR51	8.80 ± 1.0	3.2 ± 0.2	26 ± 3.0	0.60 ± 0.03	340 Grams
CSR100	11.0 ± 1.0	4.5 ± 0.5	26 ± 3.0	0.70 ± 0.03	600 Grams
CSR200	13.5 ± 1.0	5.0 ± 0.5	30 ± 3.0	0.80 ± 0.03	1050 Grams
CSR300	15.5 ± 1.0	5.5 ± 0.5	30 ± 3.0	0.80 ± 0.03	1200 Grams
CSR400	19.0 ± 1.0	6.0 ± 0.5	30 ± 3.0	0.80 ± 0.03	1620 Grams
CSR500	19.0 ± 1.0	8.0 ± 0.5	30 ± 3.0	0.80 ± 0.03	3100 Grams

GENERAL SPECIFICATIONS

Type	Power Rating (at 70°C)	Maximum Working Voltage	Maximum Overload Voltage	Minimum Resistance	Maximum Resistance	Resistance Tolerance	Available Resistance Values
CSR20	1/4W	200V	400V	68mΩ	510mΩ	±1%~5%	E-24/E-96
CSR25	1/3W	200V	400V	68mΩ	510mΩ	±1%~5%	E-24/E-96
CSR207	0.6W	200V	400V	68mΩ	510mΩ	±1%~5%	E-24/E-96
CSR51	1/2W	250V	500V	68mΩ	510mΩ	±1%~5%	E-24/E-96
CSR100	1W	250V	500V	68mΩ	510mΩ	±1%~5%	E-24/E-96
CSR200	2W	300V	600V	68mΩ	510mΩ	±1%~5%	E-24/E-96
CSR300	3W	350V	700V	68mΩ	510mΩ	±1%~5%	E-24/E-96
CSR400	4W	350V	700V	68mΩ	510mΩ	±1%~5%	E-24/E-96
CSR500	5W	500V	1000V	68mΩ	510mΩ	±1%~5%	E-24/E-96

Special sizes, values, and specifications not listed available on special order.

■ TAPING/PACKING SPECIFICATIONS

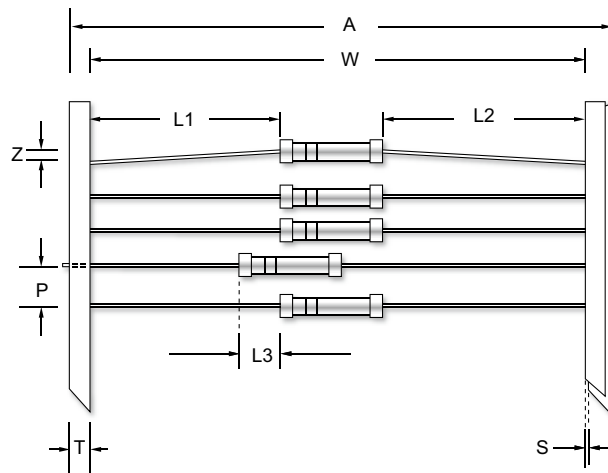

Unit (mm)

Type	A Max.	L1-L2 (Max.)	L3 (Max.)	P ±0.5	S (Max.)	T ±0.5	W ±1.5	Z (Max.)
CSR20	65	±1.0	0.5	5.0	0.8	6.0	52.5	1.2
CSR25	65	±1.0	0.5	5.0	0.8	6.0	52.5	1.2
CSR207	65	±1.0	0.5	5.0	0.8	6.0	52.5	1.2
CSR51	65	±1.0	0.5	5.0	0.8	6.0	52.5	1.2
CSR100	65	±1.0	0.5	5.0	0.8	6.0	52.5	1.2
CSR200	76	±1.5	1.0	10.0	0.8	6.0	63.5	1.2
CSR300	76	±1.5	1.0	10.0	0.8	6.0	63.5	1.2
CSR400	76	±1.5	1.0	10.0	0.8	6.0	63.5	1.2
CSR500	76	±1.5	1.0	10.0	0.8	6.0	63.5	1.2

Type No.	Packing	CSR20/25/207	CSR51	CSR100	CSR200	CSR300	CSR400	CSR500
Minimum Packing QTY (pcs)	Ammo pack	5000	2000	1000	500	500	500	400

Quality • Reliability
Cost-Down via Technology

CSR

POWER DERATING CURVE

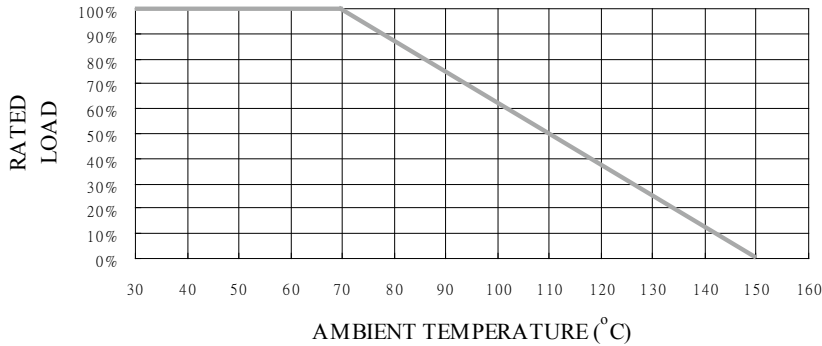

PART NUMBER

Example: CSR100JR330TKZTB1K0

CSR100	J	R330	TKZ	TB1K0
Type	Tolerance*	Resistance	TCR	Packaging
	F (1%) G (2%) J (5%)	0.33Ω 4-character code containing - 3 significant digits 1 letter multiplier <u>MULTIPLIER</u> R = 1 K = 10 ³ M = 10 ⁶ G = 10 ⁹	3-character code TKZ = Default Product Temperature Coefficient. Information of typical product temperature coefficient can be found in the Technical Summary section of the datasheet.**	5-character code TB = Tape Box (pieces per box) <u>CSR20/25/207</u> 5K0 = 5,000 <u>CSR51</u> 2K0 = 2,000 <u>CSR100</u> 1K0 = 1,000 <u>CSR200/300/400</u> 500 = 500 <u>CSR500</u> 400 = 400

* Listed values may not be applicable to all resistance values. Please check with us before placing order.

** For the availabilities of non-default temperature coefficient, please check with us. Reference for TCR letter codes can be found in section (4) of Part Number Construction in the Appendices.

TECHNICAL SUMMARY

Characteristics	Limits	
Dielectric Withstanding Voltage, VAC or DC	CSR20 CSR25/207 CSR51 CSR100/200/300/400/500	300 500 700 1000
Temperature Coefficient, PPM /°C*	±100, ± 200, ± 300	
Operating Temperature Range, °C	-55 ~ +150	
Insulation Resistance, MΩ	>10 ⁴	

* Not applicable to all resistance values. Please check with us regarding the PPM of specific resistance value(s).

■ PERFORMANCE SPECIFICATIONS

Characteristics	Test Conditions	Limits
Short Time Overload	IEC 60115-1 4.13 5 seconds 2.5x rated voltage (not over max. overload voltage)	±1%, 2%: ±0.75% ±5%: ±2%
Load Life In Humidity	IEC 60115-1 4.24 56 days rated load at (40±2)°C and (93±3)% relative humidity	±3%
Load Life 1,000 hours	IEC 60115-1 4.25.1 Rated load with 1.5 hours ON, 0.5 hours OFF, at (70±2)°C	±3%
Resistance To Soldering Heat	IEC 60115-1 4.18.2 Leads immersed till 3mm from the body in (260±5)°C solder for 10±1 seconds	±1%
Solderability	IEC 60115-1 4.17.2 Solder area covered after (235±3)°C/(2±0.2) seconds with flux applied	95% Min.
Vibration	IEC 60115-1 4.22 Six hours in each parallel and axial direction with a simple harmonic motion having an amplitude of 0.75mm and 10 to 500 Hz.	±1%
Thermal Endurance	IEC 60115-1 4.25.3 1000 hours at 150°C without load	±1%
Thermal Shock	IEC 60115-1 4.19 -55°C 30minutes, +150°C 30minutes, 5 cycles	±2%

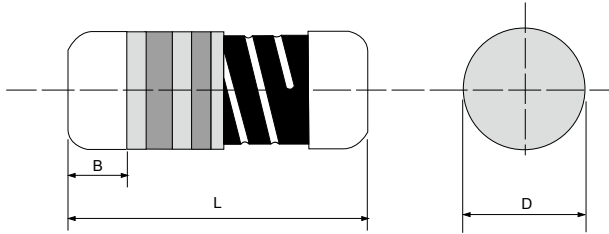

Specifications Per

• IEC 60115-1

Features

- High power handling
- Superior reliability and stability
- SMD enabled structure with excellent solderability
- Products meet RoHS requirements and do not contain substances of very high concern identified by European Chemicals Agency

DIMENSIONS

Type	Body Length (L, mm)	Body Diameter (D, mm)	Soldering Spot (B, mm)	Net Weight Per 1000 pcs
EFP204	3.52 ± 0.08	1.35 ± 0.1	0.6 Min.	17 grams
EFP101	5.90 ± 0.20	2.20 ± 0.1	1.0 Min.	66 grams
EFP201	8.50 ± 1.00	3.00 ± 0.2	1.3 Min.	186 grams
EFP301	10.5 ± 1.00	4.00 ± 0.5	1.6 Min.	446 grams
EFP401	12.6 ± 1.50	4.60 ± 0.7	1.8 Min.	750 grams
EFP501	14.6 ± 2.00	5.10 ± 1.0	2.0 Min.	1000 grams

GENERAL SPECIFICATIONS

Type	Power Rating (at 70°C)	Maximum Working Voltage	Maximum Overload Voltage	Minimum Resistance	Maximum Resistance	Resistance Tolerance	Available Resistance Values
EFP204	1/2W	250V	500V	0Ω	1MΩ	±0.5%~5%	E-24 / E-96
EFP101	1W	300V	600V	0Ω	1MΩ	±0.5%~5%	E-24 / E-96
EFP201	2W	350V	700V	0Ω	4.7MΩ	±0.5%~5%	E-24 / E-96
EFP301	3W	400V	800V	0Ω	6.8MΩ	±0.5%~5%	E-24 / E-96
EFP401	4W	400V	800V	0Ω	8.2MΩ	±0.5%~5%	E-24 / E-96
EFP501	5W	450V	900V	0Ω	10MΩ	±0.5%~5%	E-24 / E-96

Special sizes, values, and specifications not listed available on special order.
For values between 1mΩ & 510mΩ, please see CSM series.

POWER DERATING CURVE

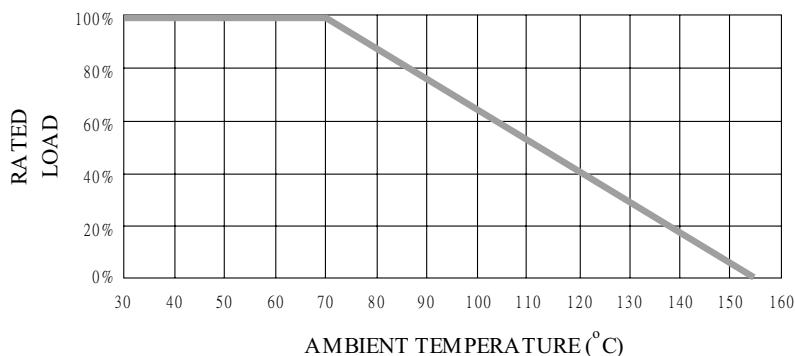

TECHNICAL SUMMARY

Characteristics	Limits
Dielectric Withstanding Voltage, VAC or VDC	EFP204: 300 EFP101: 500 EFP201: 700 EFP301, EFP401, EFP501: 1000
Temperature Coefficient, PPM / °C*	±200, ±400, ±600, ±800
Operating Temperature Range, °C	-55 ~ +155
Insulation Resistance, MΩ	>10 ⁴
Failure Rate in Time, pcs / 10 ⁹ device hours	<1
Tin Whisker (JESD201 Temperature Cycling & High Temp./ Humidity Storage), μm	<5

* Not applicable to all resistance values. Please check with us regarding the PPM of specific resistance value(s).

PART NUMBER

Example: EFP401J1M49TKZBK500

EFP401	J	1M49	TKZ	BK500
Type	Tolerance*	Resistance	TCR	Packaging
	D (0.5%) F (1%) G (2%) J (5%)	1.49MΩ 4-character code containing - 3 significant digits 1 letter multiplier <u>MULTIPLIER</u> R = 1 K = 10 ³ M = 10 ⁶ G = 10 ⁹	3-character code TKZ = Default Product Temperature Coefficient. Information of typical product temperature coefficient can be found in the Technical Summary section of the datasheet.**	Bulk 500 pieces 5-character code TR = Tape Reel (pieces per reel) <u>EFP204</u> 3K0 = 3,000 6K0 = 6,000*** 10K = 10,000*** <u>EFP101</u> 2K0 = 2,000 6K0 = 6,000*** 10K = 10,000*** <u>EFP201</u> 2K5 = 2,500 <u>EFP301</u> 2K0 = 2,000 BK = Bulk <u>EFP401/EFP501</u> BK + Quantity

* Listed values may not be applicable to all resistance values. Please check with us before placing order.

** For the availabilities of non-default temperature coefficient, please check with us. Reference for TCR letter codes can be found in section (4) of Part Number Construction in the Appendices.

*** upon request

■ SINGLE SURGE PERFORMANCE

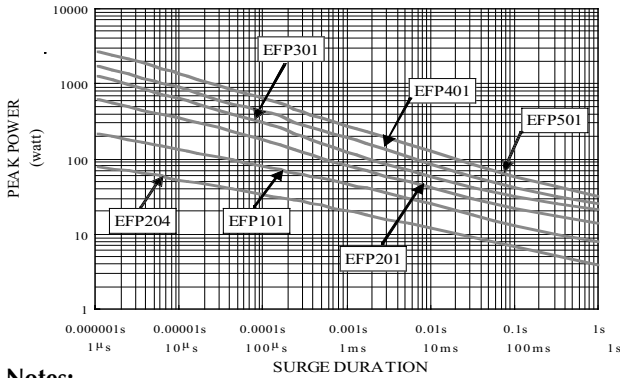

■ SURGE POWER DERATING CURVE

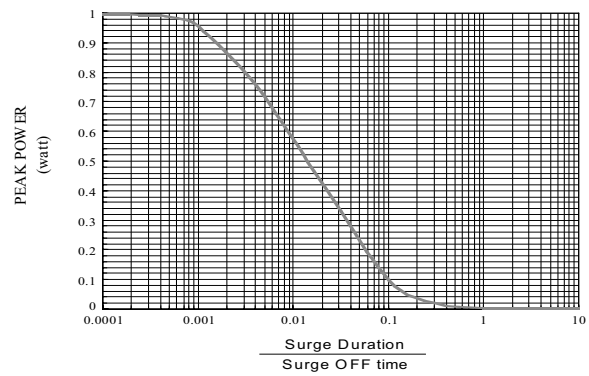

Notes:

1. Above graph is accurate for NON REPETITIVE applications operating in an ambient temperature of 70°C or less. For temperatures above 70°C, the graph power must be derated further by 1.18% per °C.
2. For applicable surge power in continuous-surge applications please see SURGE POWER DERATING CURVE above.

■ PERFORMANCE SPECIFICATIONS

Characteristics	Test Conditions	Limits	
Short Time Overload	IEC 60115-1 4.13 5 seconds 2.5x rated voltage (not over max. overload voltage)	±0.5%, 1%: ± 2%: ±5%:	±0.5% ±0.8% ±2%
Load Life	IEC 60115-1 4.25.1 Rated load 1000 hrs with 1.5 hours ON, 0.5 hours OFF, at (70±2)°C	±5%	
Load Life In Humidity	IEC 60115-1 4.24 56 days rated load at (40±2)°C and (93±3)% relative humidity	±5%	
Resistance To Soldering Heat	IEC 60115-1 4.18.2 Dip the resistor into a solder bath measured (260±5)°C and hold it for a 10±1 seconds	±1%	
Periodic Electric Overload	IEC 60115-1 4.39 3.9x rated voltage (not over max. overload voltage) with 0.1s ON, 2.5s OFF for 1,000 cycles	±5%	
Solderability	IEC 60115-1 4.17.2 Solder area covered after (235±3)°C / (2±0.2) seconds with flux applied	> 95%	
Thermal Endurance	IEC 60115-1 4.25.3 1,000 hours at 155°C without load	±1%	
Thermal Shock	IEC 60115-1 4.19 -55°C 30minutes, +155°C 30minutes, 5 cycles	±2%	
Single pulse high voltage overload	IEC 60115-1 4.27 10 pulses of 10/700µs at 10x rated voltage (not over max. overload voltage) with interval of 60 sec.	±2%	
Electrostatic discharge (Human body model)	IEC 60115-1 4.38 3 positive & 3 negative discharges with 4KV source	±5%	
Climatic test	IEC 60115-1 4.23 4.23.2 - dry heat: 16 hours 155°C 4.23.3 - damp heat: 24 hours 55°C with 95% relative humidity 4.23.4 - cold: 2 hours -55°C 4.23.5 - negative air pressure: 2 hour 8.5kPa at (25±10)°C 4.23.6 - damp heat cyclic: 5 days 55°C with 95% relative humidity 4.23.7 - DC load: rated voltage at -55°C and 155°C each 1 Min.	±2%	
Flammability	IEC 60115-1 4.35 Needle flame test 10s	No burning after 30s	
Vibration	IEC 60115-1 4.22 Six hours in each parallel and axial direction with a simple harmonic motion having an amplitude of 0.75mm and 10 to 500 Hz.	±1%	
Bending test	IEC 60115-1 4.33 Pressing depth 2mm, 3 times	±0.5%	

Quality • Reliability
Cost-Down via Technology

EFP

■ SUGGESTED PAD LAYOUT

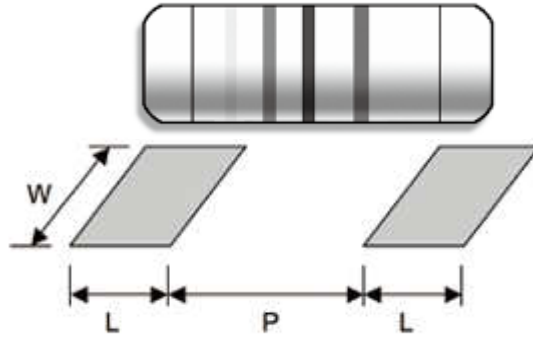

Type	Soldering Mode	Pad Length (L, mm, Min.)	Pad Spacing (P, mm)	Pad Width (W, mm, Min.)
EFP204	Reflow	1.0	2.0 ± 0.2	1.6
	Wave	1.2	2.0 ± 0.2	1.6
EFP101	Reflow	2.0	3.0 ± 0.3	3.0
	Wave	2.5	3.0 ± 0.3	3.0
EFP201	Reflow	3.0	4.9 ± 0.3	3.7
	Wave	3.5	4.8 ± 0.3	4.0
EFP301	Reflow (Not recommended)	4.0	6.2 ± 0.4	4.5
	Wave	4.5	6.0 ± 0.4	5.0
EFP401	Reflow (Not recommended)	4.5	8.0 ± 0.4	5.0
	Wave	5.0	7.7 ± 0.4	5.5
EFP501	Reflow (Not recommended)	5.0	9.3 ± 0.4	5.5
	Wave	5.0	9.0 ± 0.4	5.5

For better heat dissipation / lower heat resistance, increase W & L.

■ COVER TAPE PEELING SPECIFICATION

Recommended peeling force:

EFP204, EFP101: 50±5gf EFP201, EFP301: 70±10gf EFP401, EFP501: 80±10gf

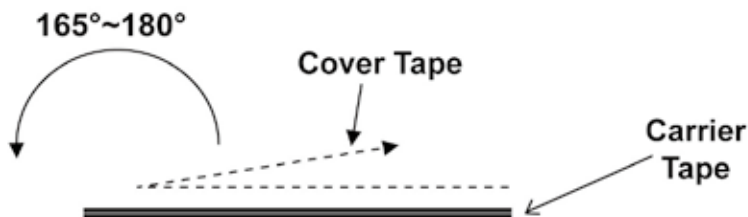

Quality • Reliability
Cost-Down via Technology

EFR

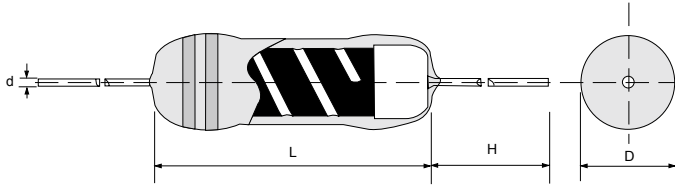

Specifications Per

• IEC 60115-4

Features

- Flameproof multi-layer coating meets UL 94 V-0
- Flameproof feature meets overload test UL 1412
- High power handling in small size
- Anti-surge capability
- Products meet RoHS requirements and do not contain substances of very high concern identified by European Chemicals Agency

■ DIMENSIONS

Type	Body Length (L, mm)	Body Diameter (D, mm)	Lead Wire Length (H, mm)	Lead Wire Diameter (d, mm)	Net Weight Per 1000Pcs
EFR52	6.50 ± 1.0	2.4 ± 0.2	26 ± 3.0	0.55 ± 0.03	220 Grams
EFR207	6.50 ± 1.0	2.4 ± 0.2	26 ± 3.0	0.60 ± 0.03	220 Grams
EFR101	8.80 ± 1.0	3.2 ± 0.2	28 ± 3.0	0.60 ± 0.03	340 Grams
EFR201	11.0 ± 1.0	4.0 ± 0.5	28 ± 3.0	0.70 ± 0.03	500 Grams
EFR300	15.5 ± 1.0	5.5 ± 0.5	30 ± 3.0	0.80 ± 0.03	1200 Grams
EFR400	19.0 ± 1.0	6.0 ± 0.5	30 ± 3.0	0.80 ± 0.03	1600 Grams
EFR500	19.0 ± 1.0	8.0 ± 0.5	30 ± 3.0	0.80 ± 0.03	3100 Grams

■ GENERAL SPECIFICATIONS

Type	Power Rating (at 70°C)	Maximum Working Voltage	Maximum Overload Voltage	Minimum Resistance	Maximum Resistance	Resistance Tolerance	Available Resistance Values
EFR52	1/2W	500V	700V	1Ω	1MΩ	±1%, ±2%, ±5%	E-24/E-96
EFR207	1W	500V	800V	1Ω	1MΩ	±1%, ±2%, ±5%	E-24/E-96
EFR101	1W	600V	900V	1Ω	1MΩ	±2%, ±5%	E-24/E-48
EFR201	2W	750V	1000V	1Ω	1MΩ	±2%, ±5%	E-24/E-48
EFR300	3W	800V	1200V	1Ω	560KΩ	±2%, ±5%	E-24/E-48
EFR400	4W	800V	1200V	1Ω	180KΩ	±2%, ±5%	E-24/E-48
EFR500	5W	800V	1200V	1Ω	180KΩ	±2%, ±5%	E-24/E-48

Special sizes, values, and specifications not listed available on special order.

Quality • Reliability
Cost-Down via Technology

■ PART NUMBER

Example: EFR101J100KTKZTB2K0

EFR101	J	100K	TKZ	TB2K0
Type	Tolerance*	Resistance	TCR	Packaging
	F (1%) G (2%) J (5%)	100KΩ 4-character code containing - 3 significant digits 1 letter multiplier MULTIPLIER R = 1 K = 10 ³ M = 10 ⁶ G = 10 ⁹	3-character code TKZ = Default Product Temperature Coefficient. Information of typical product temperature coefficient can be found in the Technical Summary section of the datasheet.**	5-character code TB = Tape Box (pieces per box) <u>EFR52/EFR207</u> 5K0 = 5,000 <u>EFR101</u> 2K0 = 2,000 <u>EFR201</u> 1K0 = 1,000 <u>EFR300/400</u> 500 = 500 <u>EFR500</u> 400 = 400

* Listed values may not be applicable across the product series/all resistance values. Please check with us before placing order.

** For the availabilities of non-default temperature coefficient, please check with us. Reference for TCR letter codes can be found in section (4) of Part Number Construction in the Appendices.

■ TECHNICAL SUMMARY

Characteristics	Limits
Dielectric Withstanding Voltage, VAC or DC	500
Temperature Coefficient, PPM / °C*	±50, ±100, ±200, ±300, ±500
Operating Temperature Range, °C	-55~+200
Insulation Resistance, MΩ	10 ⁴

* Not applicable to all resistance values. Please check with us regarding the PPM of specific resistance value(s).

■ POWER DERATING CURVE

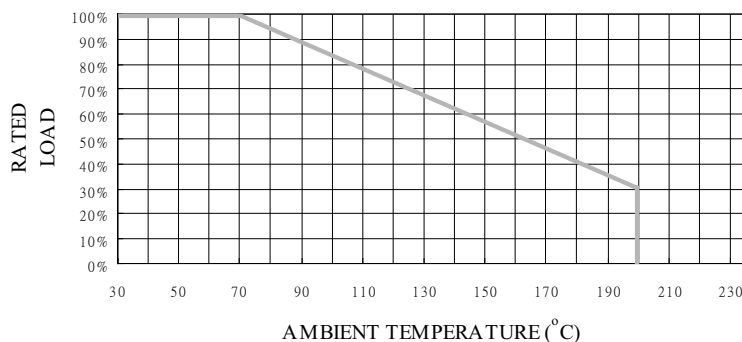

Quality • Reliability
Cost-Down via Technology

EFR

■ TAPING/PACKING SPECIFICATIONS

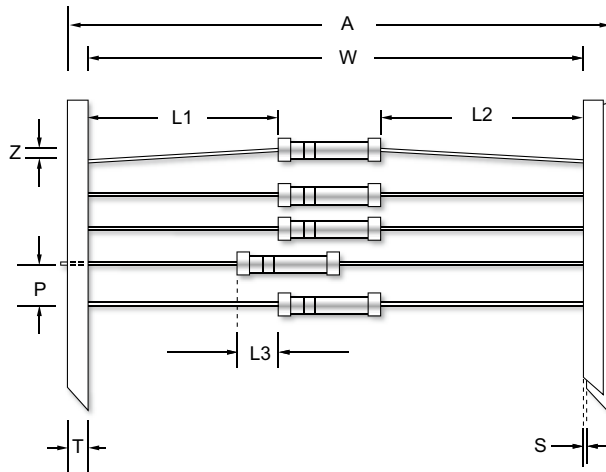

Unit (mm)

Type	A Max.	L1-L2 (Max.)	L3 (Max.)	P ±0.5	S (Max.)	T ±0.5	W ±1.5	Z (Max.)
EFR52	65	±1.0	0.5	5.0	0.8	6.0	52.5	1.2
EFR207	65	±1.0	0.5	5.0	0.8	6.0	52.5	1.2
EFR101	65	±1.0	0.5	5.0	0.8	6.0	52.5	1.2
EFR201	76	±1.5	1.0	10.0	0.8	6.0	63.5	1.2
EFR300	76	±1.5	1.0	10.0	0.8	6.0	63.5	1.2
EFR400	76	±1.5	1.0	10.0	0.8	6.0	63.5	1.2
EFR500 L option	76	±1.5	1.0	10.0	0.8	6.0	63.5	1.2
	95	±1.5	1.0	10.0	0.8	6.0	77	1.2

■ PERFORMANCE SPECIFICATIONS

Characteristics	Test Conditions	Limits
Short Time Over Load	IEC 60115-1 4.13 5 seconds 2.5x rated voltage (not over max. overload voltage)	±2%
Load Life In Humidity	IEC 60115-1 4.24 56 days rated load at (40±2)°C and (93±3)% relative humidity	±1.5%
Load Life 1,000 hours	IEC 60115-1 4.25.1 Rated load with 1.5 hours ON, 0.5 hours OFF, at (70±2)°C	EFR52/207: ±1.5% EFR101/201: ±2.0% EFR300/400/500: ±5.0%
Resistance To Soldering Heat	IEC 60115-1 4.18.2 Leads immersed till 3mm from the body in (260±5)°C solder for 10±1 seconds	±1%
Solderability	IEC 60115-1 4.17.2 Solder area covered after (235±3)°C / (2±0.2) seconds with flux applied	90% Min.
Vibration	IEC 60115-1 4.22 Six hours in each parallel and axial direction with a simple harmonic motion having an amplitude of 0.75mm and 10 to 500 Hz.	±1%
Thermal Endurance	IEC 60115-1 4.25.3 1000 hours at 200°C without load	±1%
Thermal Shock	IEC 60115-1 4.19 -55°C 30minutes, +155°C 30minutes, 5 cycles	±2%
Resistance to Climatic Sequence	IEC 60115-1 4.23 Dry heat, damp heat cycle, cold, low air pressure	±2%
Terminal Strength	IEC 60115-1 4.16.2 2.5kg direct load for 10 seconds in the longitudinal direction of the terminal leads	±1%

ESM ESD Surge MELF Absorber

Quality • Reliability
Cost-Down via Technology

ESM

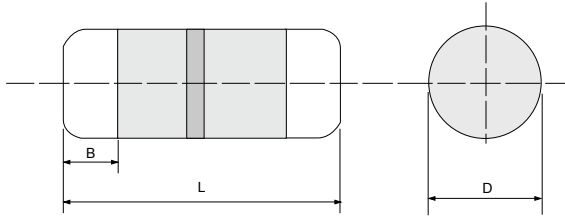

Features

- Protects through sparking over the porous layer when surge exceeds the spark-over voltage
- Patented construction with reduced costs
- High insulation resistance, low capacitance, and fast response time
- RoHS and REACH compliant

Applications

- Human body model ESD protection
- Telephone/Fax Machine/Modem Protection
- Signal Line Protection
- USB protection
- Ethernet protection
- Low voltage power protection
- Support products to comply with IEC61000-4-2, ISO10605 requirements, etc.

■ DIMENSIONS

Type	Body Length (L, mm)	Body Diameter (D, mm)	Soldering Spot (B, mm)	Net Weight Per 1000 pcs
ESM204	3.52 ± 0.08	1.35 ± 0.1	0.6 Min.	17 grams

Cross-Section View

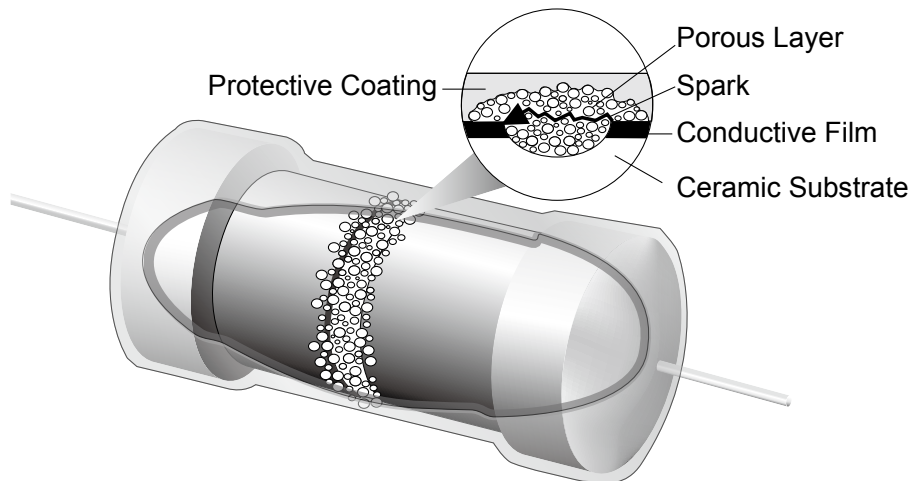

Legal disclaimer: This international patent is covered by Paris Convention for the Protection of Industrial Property under World Intellectual Property Organization (WIPO). Plagiarism and imitation shall be severely punished.

■ GENERAL SPECIFICATIONS

Series	Type Name	Color Code	DC spark-over voltage
ESM	ESM204	White	1300V ± 30%

Special sizes, values, and specifications not listed available on special order.

■ PART NUMBER

Example: ESM204N1300XXXTR3K0

ESM204	N	1300	XXX	TR3K0
Type	Tolerance	Spark-Over Voltage	TCR	Packaging
	N (30%)	1300V 4-character code	3-character code Parameter Not Applicable	5-character code TR = Tape Reel (pieces per reel) 3K0 = 3,000 6K0 = 6,000* 10K = 10,000*

*upon request

■ TECHNICAL SUMMARY

Characteristics	Limits
Dielectric Withstanding Voltage, VAC or DC	500
Surge Current Capacity	60A @8/20µs (80A @2/10µs)
Operating Temperature Range, °C	-55 ~ +155
Insulation Resistance, MΩ (Measured with DC 500V)	> 100
Capacitance	≤ 1pF
Activation time	≤ 1ns

■ PERFORMANCE SPECIFICATIONS

Characteristics	Test Conditions	Limits
Resistance To Soldering Heat	IEC 60115-1 4.18.2 Dip the resistor into a solder bath measured (260±5)°C and hold it for a 10±1 seconds	Rated value 40%
Solderability	IEC 60115-1 4.17.2 Solder area covered after (235±3)°C/(2±0.2) seconds with flux applied	95% min
Vibration	IEC 60115-1 4.22 Six hours in each parallel and axial direction with a simple harmonic motion having an amplitude of 1.52mm and 10 to 2,000 Hz.	Rated values still satisfied
Thermal Endurance	IEC 60115-1 4.25.3 1000 hours at 155°C without load	Rated value 40%
Thermal Shock	IEC 60115-1 4.19 -55°C 30minutes, +155°C 30minutes, 5 cycles	Rated value 40%
Surge Life	3000pF/ 10KV/ 0ohm, times = 300	No function failure

Quality • Reliability
Cost-Down via Technology

ESM

■ SUGGESTED PAD LAYOUT

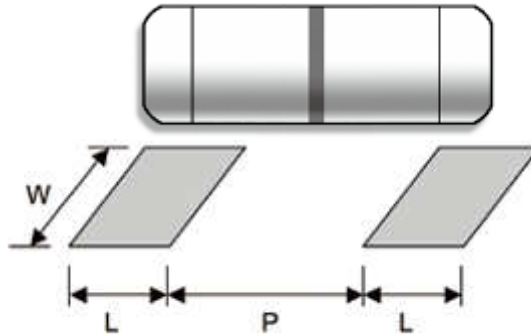

Type	Soldering mode	Pad Length (L, mm, min.)	Pad Spacing (P, mm)	Pad Width (W, mm, min.)
ESM204	Reflow	1.0	2.0 ± 0.2	1.6
	Wave	1.2	2.0 ± 0.2	1.6

For better heat dissipation / lower heat resistance, increase W & L.

■ COVER TAPE PEELING SPECIFICATION

Recommended peeling force:

ESM204: 50±5gf

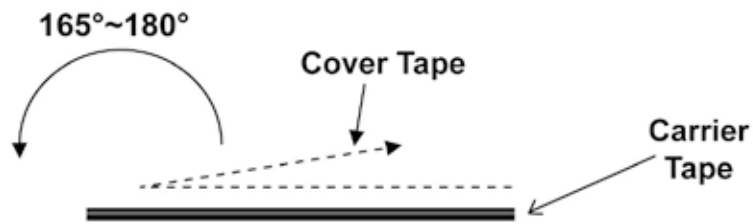

■ APPLICATIONS

Telephone/Fax Machine/Modem/USB/Mouse/Ethernet/Low-voltage power Protection (common-mode protection)

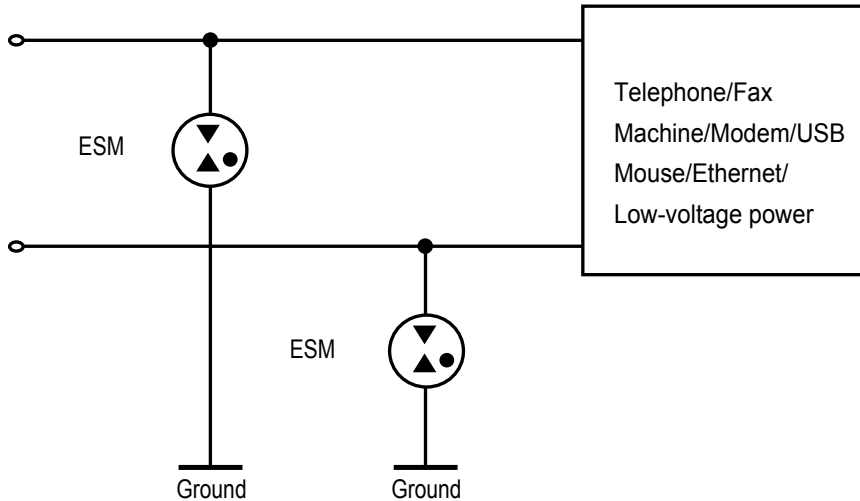

These ESM absorbers protect against common-mode interference voltages, i.e. surge voltages that appear in both exchange lines connecting to the ground. In the event of voltage overload, the ESM protects both exchange lines by conducting the surge current away to the ground.

Signal Line Protection (differential-mode protection)

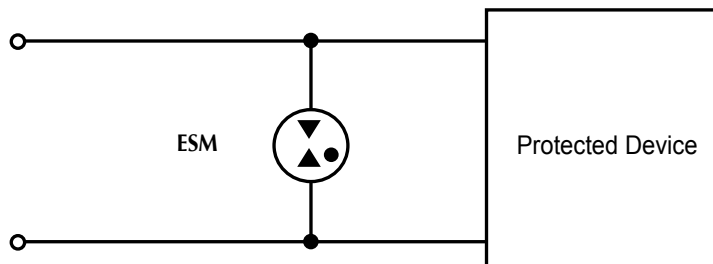

Signal circuits often run with no ground conductor. A ESM circuit located between the two signal lines offers differential mode protection by preventing the occurrence of large potential difference at the input of the equipment to be protected

Series of ESD Surge MELF Absorber (ESM) and Metal-Oxide Varistor (MOV)

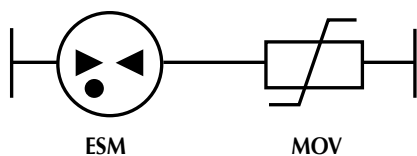

Benefits:

1. Capacitance of this branch circuit would be reduced to pF level.
2. MOV has almost no current leakage.
3. MOV aging-related issue would be greatly improved,, increasing reliability of the circuit.

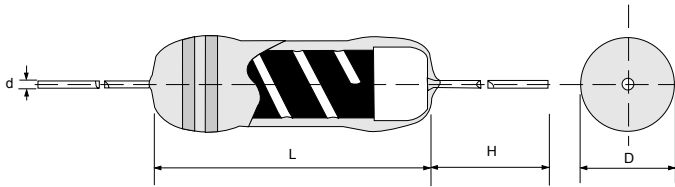

Specifications Per

• IEC 60115-1, IEC 60115-4

Features

- Flameproof multi-layer coating meets UL 94 V-0
- Flameproof feature meets overload test UL 1412
- Color code per MIL & EIA standards
- Special tin-plated electrolytic copper lead wire
- Products meet RoHS requirements and do not contain substances of very high concern identified by European Chemicals Agency

DIMENSIONS

Type	Body Length (L, mm)	Body Diameter (D, mm)	Lead Wire Length (H, mm)	Lead Wire Diameter (d, mm)	Net Weight Per 1000Pcs
FGE50	8.8 ± 1.0	3.2 ± 0.2	28 ± 3.0	0.6 ± 0.03	340 Grams
FGE101	8.8 ± 1.0	3.2 ± 0.2	28 ± 3.0	0.6 ± 0.03	340 Grams
FGE100	11.0 ± 1.0	4.0 ± 0.5	28 ± 3.0	0.7 ± 0.03	500 grams
FGE201	11.0 ± 1.0	4.0 ± 0.5	28 ± 3.0	0.8 ± 0.03	510 grams
FGE200	11.0 ± 1.0	4.5 ± 0.5	28 ± 3.0	0.8 ± 0.03	500 grams
FGE301	13.5 ± 1.0	5.0 ± 0.5	30 ± 3.0	0.8 ± 0.03	1050 grams

GENERAL SPECIFICATIONS

Type	Power Rating (at 70°C)	Maximum Working Voltage	Maximum Overload Voltage	Minimum Resistance	Maximum Resistance	Resistance Tolerance	Available Resistance Values
FGE50	1/2W	300V	600V	2.2Ω	10KΩ	±5%	E-24
FGE101	1W	300V	600V	2.2Ω	10KΩ	±5%	E-24
FGE100	1W	350V	600V	2.2Ω	10KΩ	±5%	E-24
FGE201	2W	350V	600V	2.2Ω	10KΩ	±5%	E-24
FGE200	2W	350V	600V	2.2Ω	10KΩ	±5%	E-24
FGE301	3W	350V	700V	2.2Ω	10KΩ	±5%	E-24

* Please contact us for 3W type (FGE301), resistance values, sizes, or specifications not listed.

Quality • Reliability
Cost-Down via Technology

■ PART NUMBER

Example: FGE101J10K0TKZTB2K0

FGE101	J	10K0	TKZ	TB2K0
Type	Tolerance	Resistance	TCR	Packaging
	J (5%)	10KΩ 4-character code containing - 3 significant digits 1 letter multiplier MULTIPLIER R = 1 K = 10 ³ M = 10 ⁶ G = 10 ⁹	3-character code TKZ = Default Product Temperature Coefficient. Information of typical product temperature coefficient can be found in the Technical Summary section of the datasheet.*	5-character code TB = Tape Box (pieces per box) FGE50/101 2K0 = 2,000 FGE100/201/200 1K0 = 1,000 FGE301 500 = 500

* For the availabilities of non-default temperature coefficient, please check with us. Reference for TCR letter codes can be found in section (4) of Part Number Construction in the Appendices.

■ TECHNICAL SUMMARY

Characteristics	Limits	
Dielectric Withstanding Voltage, V AC or DC	FGE50 FGE101 FGE100 FGE200 / 201 / 301	300 350 500 700
Temperature Coefficient, PPM/°C*	FGE50 / 101 / 100 / 201	±200, ±400
	FGE200	±200
	FGE301	±400
Operating Temperature Range, °C	-55~+200	
Insulation Resistance, MΩ	10 ⁴	
Fusing Condition, W	Interrupts in max. 60 seconds at below overload FGE50: 8 FGE101 / FGE100 / 201: 16 FGE200: 20 FGE301: 24	
Power Derating, Linear	100% at < 70°C, zero at 200°C	

* Not applicable to all resistance values. Please check with us regarding the PPM of specific resistance value(s).

■ PERFORMANCE SPECIFICATIONS

Characteristics	Test Conditions	Limits	
Short Time Overload	IEC 60115-1 4.13 2 seconds 2.5x rated voltage (not over max. overload voltage)	±5%	
Load Life In Humidity	IEC 60115-1 4.24 56 days rated load at (40±2)°C and (93±3)% relative humidity	±5%	
Load Life 1,000 hours	IEC 60115-1 4.25.1 Rated load with 1.5 hours ON, 0.5 hours OFF, at (70±2)°C	±5%	
Resistance To Soldering Heat	IEC 60115-1 4.18.2 Leads immersed till 3mm from the body in (260±5)°C solder for 10±1 seconds	±1%	
Solderability	IEC 60115-1 4.17.2 Solder area covered after (230±3)°C/(2±0.2) seconds with flux applied	FGE50 / 101 / 100 / 201	90% Min.
		FGE200 / 301	95% Min.
Vibration	IEC 60115-1 4.22 Six hours in each parallel and axial direction with a simple harmonic motion having an amplitude of 1.52mm and 10 to 2,000 Hz.	±1%	
Thermal Endurance	IEC 60115-1 4.25.3 1000 hours at 200°C without load	±1%	
Thermal Shock	IEC 60115-1 4.19 -55°C 30minutes, +155°C 30minutes, 5 cycles	±2%	

Firstohm[®]

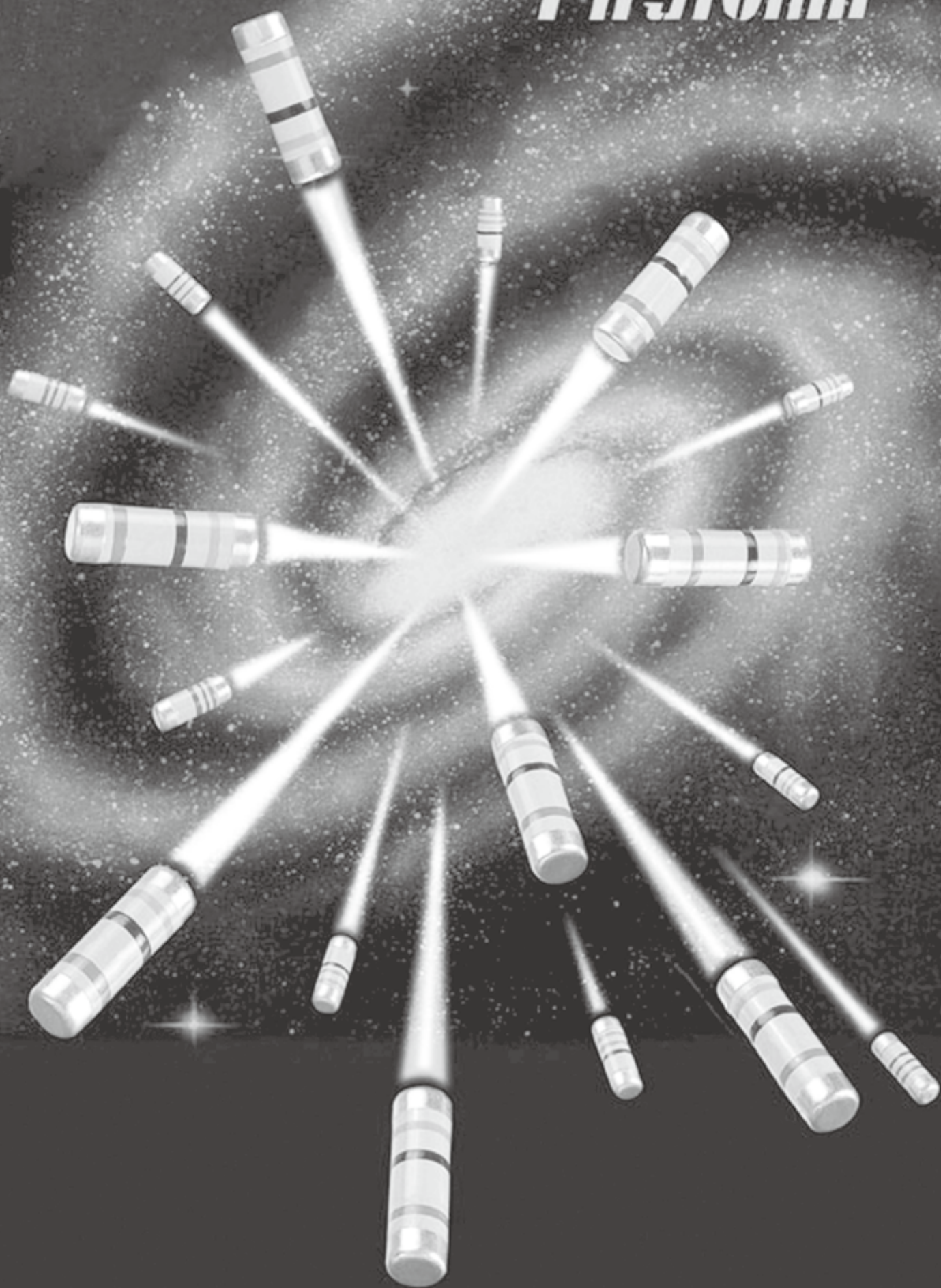

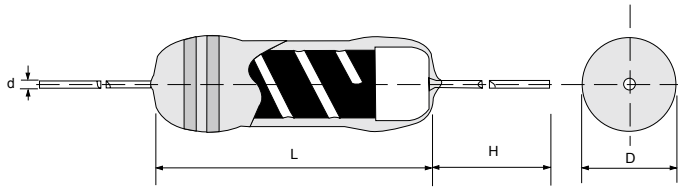

Specifications Per

• IEC 60115-1

Features

- Flameproof multi-layer coating meets UL 94V-0
- Flameproof feature meets overload test UL 1412
- Color code per MIL & EIA standards
- Special tin-plated electrolytic copper lead wire
- Products meet RoHS requirements and do not contain substances of very high concern identified by European Chemicals Agency

■ DIMENSIONS

Type	Body Length (L , mm)	Body Diameter (D, mm)	Lead Wire Length (H , mm)	Lead Wire Diameter (d , mm)	Net Weight Per 1000Pcs
FGE25	6.5 ± 0.5	2.4 ± 0.2	26 ± 3.0	0.55 ± 0.03	220 grams
FGE26	6.5 ± 0.5	2.4 ± 0.2	26 ± 3.0	0.55 ± 0.03	220 grams
FGE53	6.5 ± 0.5	2.4 ± 0.2	26 ± 3.0	0.55 ± 0.03	220 grams

■ GENERAL SPECIFICATIONS

Type	Power Rating (at 70°C)	Maximum Working Voltage	Minimum Resistance	Maximum Resistance	Resistance Tolerance	Available Resistance Values
FGE25	1/4W	250V	2.2Ω	15KΩ	±5%	E-24
FGE26	1/3W	250V	2.2Ω	15KΩ	±5%	E-24
FGE53	1/2W	350V	2.2Ω	10KΩ	±5%	E-24

Other resistance values and higher wattages available on request.

*Quality • Reliability
Cost-Down via Technology*

FGE

FGE25

FUSING CHARAC TERISTICS
USING CONST ANT VOLTAGE

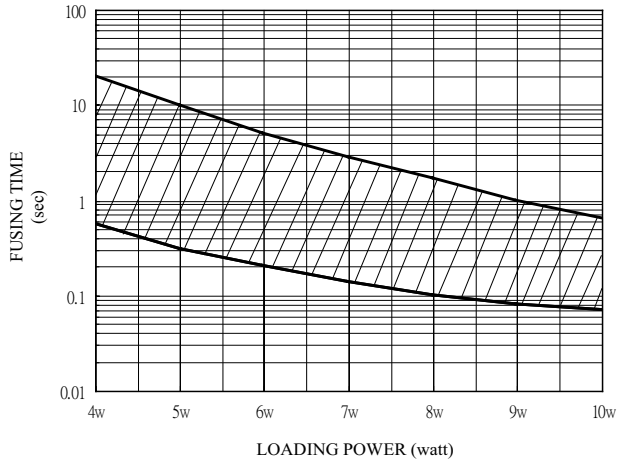

FGE26

FUSING CHARAC TERISTICS
USING CONST ANT VOLTAGE

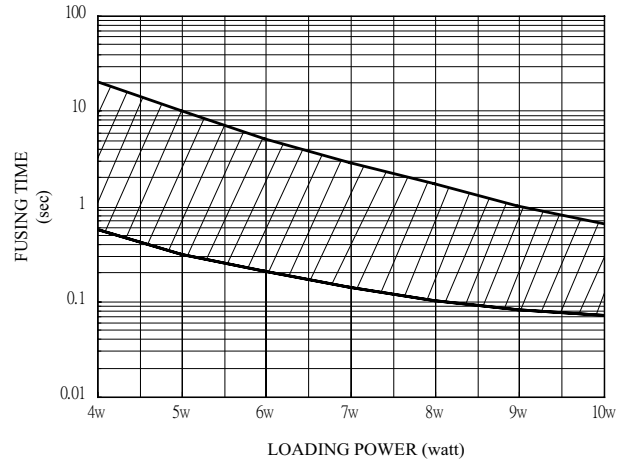

FGE53

FUSING CHARAC TERISTICS
USING CONST ANT VOLTAGE

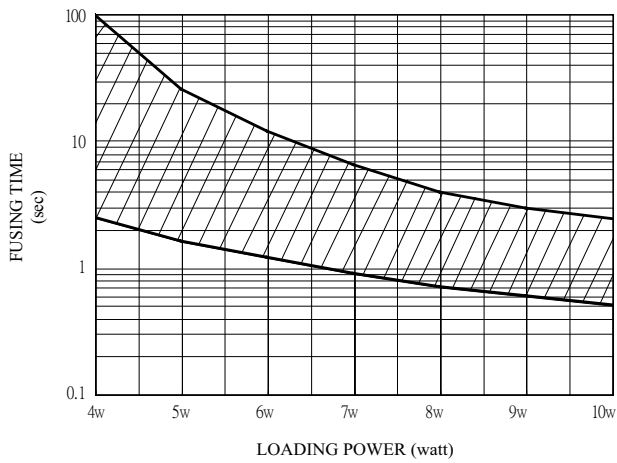

Quality • Reliability
Cost-Down via Technology

FGE

■ PART NUMBER

Example: FGE53J10K0TKZTB5K0

FGE53	J	10K0	TKZ	TB5K0
Type	Tolerance	Resistance	TCR	Packaging
	J (5%)	10KΩ 4-character code containing - 3 significant digits 1 letter multiplier MULTIPLIER R = 1 K = 10 ³ M = 10 ⁶ G = 10 ⁹	3-character code TKZ = Default Product Temperature Coefficient. Information of typical product temperature coefficient can be found in the Technical Summary section of the datasheet.*	5-character code TB = Tape Box (pieces per box) <u>FGE25/26/53</u> 5K0 = 5,000

* For the availabilities of non-default temperature coefficient, please check with us. Reference for TCR letter codes can be found in section (4) of Part Number Construction in the Appendices.

■ TECHNICAL SUMMARY

Characteristics	Limits
Dielectric Withstanding Voltage, VAC or DC	500
Temperature Coefficient, PPM / °C*	±200
Operating Temperature Range, °C	-55 ~ +155
Insulation Resistance, MΩ	10 ⁴
Power Derating, Linear	100% at < 70°C, zero at 155°C

* Not applicable to all resistance values. Please check with us regarding the PPM of specific resistance value(s).

■ PERFORMANCE SPECIFICATIONS

Characteristics	Test Conditions	Limits
Load Life In Humidity	IEC 60115-1 4.24 56 days rated load at (40±2)°C and (93±3)% relative humidity	±5%
Load Life 1,000 hours	IEC 60115-1 4.25.1 Rated load with 1.5 hours ON, 0.5 hours OFF, at (70±2)°C	±5%
Resistance To Soldering Heat	IEC 60115-1 4.18.2 Leads immersed till 3mm from the body in (260±5)°C solder for 10±1 seconds	±1%
Solderability	IEC 60115-1 4.17.2 Solder area covered after (235±3)°C/(2±0.2) seconds with flux applied	95% Min.
Vibration	IEC 60115-1 4.22 Six hours in each parallel and axial direction with a simple harmonic motion having an amplitude of 1.52mm and 10 to 2,000 Hz.	±1%
Thermal Endurance	IEC 60115-1 4.25.3 1000 hours at 155°C without load	±1%
Thermal Shock	IEC 60115-1 4.19 -55°C 30minutes, +155°C 30minutes, 5 cycles	±1%

Quality • Reliability
Cost-Down via Technology

FGE26C

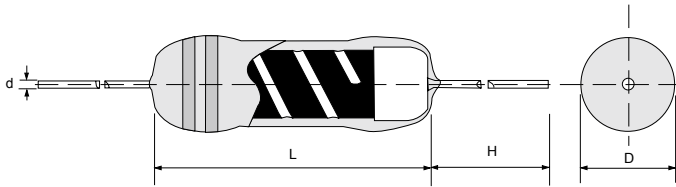

Specifications Per

- IEC 60115-1

Features

- Delay fusing within 60 sec. in case of excessive current
- Constant current fusing type
- Fuses at low magnification of power rating (5 or 10 times)
- Flameproof multi-layer coating meets UL 94V-0
- Flameproof feature meets overload test UL 1412
- Special tin-plated electrolytic copper lead wire
- Products meet RoHS requirements and do not contain substances of very high concern identified by European Chemicals Agency

DIMENSIONS

Type	Body Length (L , mm)	Body Diameter (D , mm)	Lead Wire Length (H , mm)	Lead Wire Diameter (d , mm)	Net Weight Per 1000Pcs
FGE26C	6.5 ± 0.5	2.4 ± 0.2	26 ± 3.0	0.55 ± 0.03	220 grams

GENERAL SPECIFICATIONS

Type	Power Rating (at 70°C)	Maximum Working Voltage	Minimum Resistance	Maximum Resistance	Resistance Tolerance	Available Resistance Values
FGE26C	1/4W	250V	0.1Ω	0.91Ω	±5%~10%	E-24/E-12

Other resistance values and higher wattages available on request.

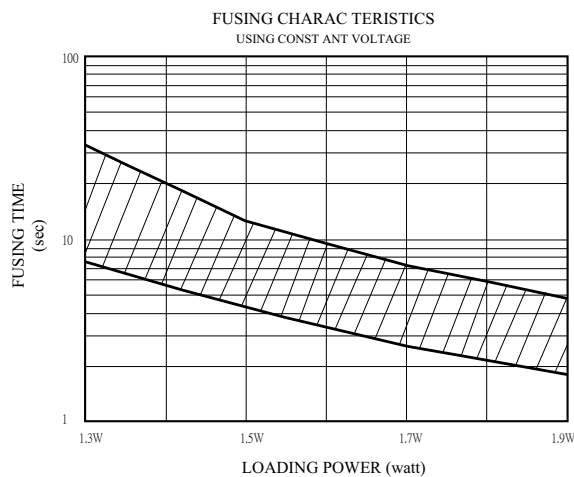

TECHNICAL SUMMARY

Characteristics	Limits
Dielectric Withstanding Voltage, VAC or DC	250
Temperature Coefficient, PPM / °C*	+2800 max.
Operating Temperature Range, °C	-55~+155
Insulation Resistance, MΩ	10 ⁴
Power Derating, Linear	100% at < 70°C, zero at 155°C

* Not applicable to all resistance values. Please check with us regarding the PPM of specific resistance value(s).

PART NUMBER

Example: FGE26CJR820TKZTB5K0

FGE26C	J	R820	TKZ	TB5K0
Type	Tolerance	Resistance	TCR	Packaging
	J (5%) K (10%)	0.82Ω 4-character code containing - 3 significant digits 1 letter multiplier <u>MULTIPLIER</u> R = 1 K = 10 ³ M = 10 ⁶ G = 10 ⁹	3-character code TKZ = Default Product Temperature Coefficient. Information of typical product temperature coefficient can be found in the Technical Summary section of the datasheet.*	5-character code TB = Tape Box (pieces per box) <u>FGE26C</u> 5K0 = 5,000

* For the availabilities of non-default temperature coefficient, please check with us. Reference for TCR letter codes can be found in section (4) of Part Number Construction in the Appendices.

PERFORMANCE SPECIFICATIONS

Characteristics	Test Conditions	Limits
Load Life In Humidity	IEC 60115-1 4.24 56 days rated load at (40±2)°C and (93±3)% relative humidity	±5%
Load Life 1,000 hours	IEC 60115-1 4.25.1 Rated load with 1.5 hours ON, 0.5 hours OFF, at (70±2)°C	±5%
Resistance To Soldering Heat	IEC 60115-1 4.18.2 Leads immersed till 3mm from the body in (260±5)°C solder for 10±1 seconds	±1%
Solderability	IEC 60115-1 4.17.2 Solder area covered after (235±3)°C/(2±0.2) seconds with flux applied	95% Min.
Vibration	IEC 60115-1 4.22 Six hours in each parallel and axial direction with a simple harmonic motion having an amplitude of 1.52mm and 10 to 2,000 Hz.	±1%
Thermal Endurance	IEC 60115-1 4.25.3 1000 hours at 155°C without load	±1%
Thermal Shock	IEC 60115-1 4.19 -55°C 30minutes, +155°C 30minutes, 5 cycles	±1%

FM Fusible MELF Resistor

Quality • Reliability
Cost-Down via Technology

FM

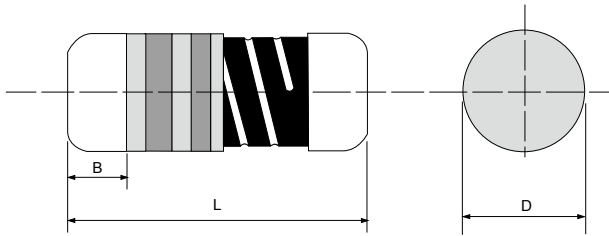

Specifications Per

- IEC 60115-1, 60115-2
- EN140401-803

Features

- SMD enabled structure
- Excellent solderability termination
- RoHS and REACH compliant

DIMENSIONS

Type	Body Length (L, mm)	Body Diameter (D, mm)	Soldering Spot (B, mm)	Net Weight Per 1000 pcs
FM26	5.90 ± 0.2	2.20 ± 0.1	1.0 Min.	66 grams
FM53	5.90 ± 0.2	2.20 ± 0.1	1.0 Min.	66 grams

GENERAL SPECIFICATIONS

Type	Power Rating (at 70°C)	Max. Working Voltage	Minimum Resistance	Maximum Resistance	Resistance Tolerance	Available Resistance Value
FM26	1/3W	250V	2.2Ω	10KΩ	±5%	E-24
FM53	1/2W	300V	2.2Ω	10KΩ	±5%	E-24

Special sizes, values, and specifications not listed available on special order.

FGE26

FUSING CHARACTERISTICS
USING CONSTANT VOLTAGE

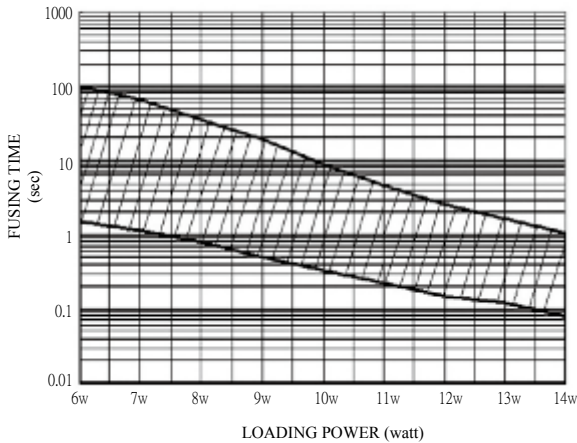

FGE53

FUSING CHARACTERISTICS
USING CONSTANT VOLTAGE

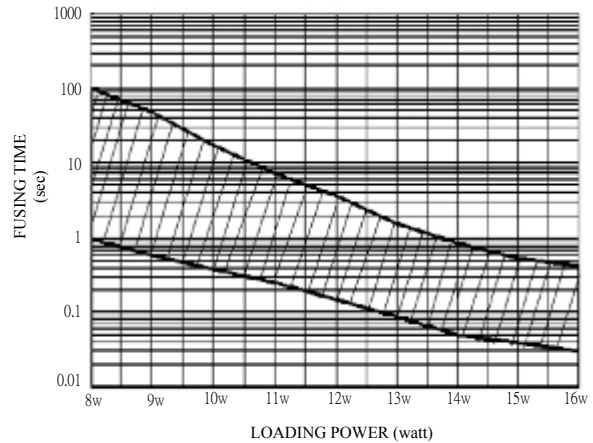

FM Fusible MELF Resistor

Quality • Reliability
Cost-Down via Technology

■ PART NUMBER

Example: FM53J10K0TKZTR2K0

FM53	J	10K0	TKZ	TR2K0
Type	Tolerance	Resistance	TCR	Packaging
	J (5%)	10KΩ 4-character code containing - 3 significant digits 1 letter multiplier <u>MULTIPLIER</u> R = 1 K = 10 ³ M = 10 ⁶ G = 10 ⁹	3-character code TKZ = Default Product Temperature Coefficient. Information of typical product temperature coefficient can be found in the Technical Summary section of the datasheet.*	5-character code TR = Tape Reel (pieces per reel) <u>FM26/FM53</u> 2K0 = 2,000 6K0 = 6,000** 10K = 10,000**

* For the availabilities of non-default temperature coefficient, please check with us. Reference for TCR letter codes can be found in section (4) of Part Number Construction in the Appendices.

** upon request

■ TECHNICAL SUMMARY

Characteristics	Limits	
Dielectric Withstanding Voltage, VAC or DC	FM26 FM53	300
Temperature Coefficient, PPM / °C*	FM26 FM53	Typically ±200
Operating Temperature Range, °C	-55 ~ +155	
Insulation Resistance, MΩ	>10 ⁴	
Power Derating, Linear	100% at < 70°C, zero at 155°C	

* Not applicable to all resistance values. Please check with us regarding the PPM of specific resistance value(s).

■ PERFORMANCE SPECIFICATIONS

Characteristics	Test Conditions	Limits
Short Time Overload	IEC 60115-1 4.13 2 seconds 2.5x rated voltage (not over max. overload voltage)	±5%
Load Life In Humidity	IEC 60115-1 4.24 56 days rated load at (40±2)°C and (93±3)% relative humidity	±5%
Load Life 1,000 hours	IEC 60115-1 4.25.1 Rated load with 1.5 hours ON, 0.5 hours OFF, at (70±2)°C	±5%
Resistance To Soldering Heat	IEC 60115-1 4.18.2 Dip the resistor into a solder bath measured of (260±5)°C and hold it for a 10±1 seconds	±1%
Solderability	IEC 60115-1 4.17.2 Solder area covered after (235±3)°C/(2±0.2) seconds with flux applied	95% Min.
Vibration	IEC 60115-1 4.22 Six hours in each parallel and axial direction with a simple harmonic motion having an amplitude of 0.75mm and 10 to 500 Hz.	±1%
Thermal Endurance	IEC 60115-1 4.25.3 1000 hours at 155°C without load	±1%
Thermal Shock	IEC 60115-1 4.19 -55°C 30minutes, +155°C 30minutes, 5 cycles	±1%

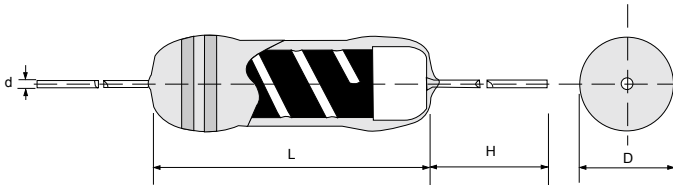

Features

- Excellent anti-surge characteristic
- Suitable for medium to high working voltage
- Flameproof coating available
- Products meet RoHS requirements and do not contain substances of very high concern identified by European Chemicals Agency

Applications

- TV, CRT Display, LCD Backlight Supply
- Copy Machine, Laser Printer
- VTR
- Switching Power Supply, AC Adapter

DIMENSIONS

Type No.	Body Length (L, mm)	Body Diameter (D, mm)	Lead Wire Length (H, mm)	Lead Wire Diameter (d, mm)	Net Weight Per 1000Pcs
HDR20	3.20 ± 1.0	1.9 ± 0.2	28 ± 3.0	0.45 ± 0.02	145 Grams
HDR25	6.50 ± 1.0	2.6 ± 0.2	26 ± 3.0	0.55 ± 0.03	220 Grams
HDR51	8.80 ± 1.0	3.2 ± 0.2	26 ± 3.0	0.70 ± 0.03	340 Grams
HDR100	11.0 ± 1.0	4.0 ± 0.5	28 ± 3.0	0.70 ± 0.03	500 Grams
HDR200	13.5 ± 1.0	5.0 ± 0.5	30 ± 3.0	0.80 ± 0.03	1050 Grams

GENERAL SPECIFICATIONS

Type	Power Rating (at 70°C)	Maximum Working Voltage	Maximum Overload Voltage	Minimum Resistance	Maximum Resistance	Resistance Tolerance	Available Resistance Values
HDR20	1/4W	500V	1KV	100KΩ	5.1MΩ	±5%	E-24
HDR25	1/4W	DC1600V AC1150V	DC3200V AC2300V	100KΩ	33MΩ	±5%	E-24
HDR51	1/2W	2KV	4KV	100KΩ	33MΩ	±5%	E-24
HDR100	1W	4KV	8 KV	100KΩ	56MΩ	±5%	E-24
HDR200	2W	5KV	10KV	100KΩ	56MΩ	±5%	E-24

Special sizes, values, and specifications not listed available on special order.

POWER DERATING CURVE

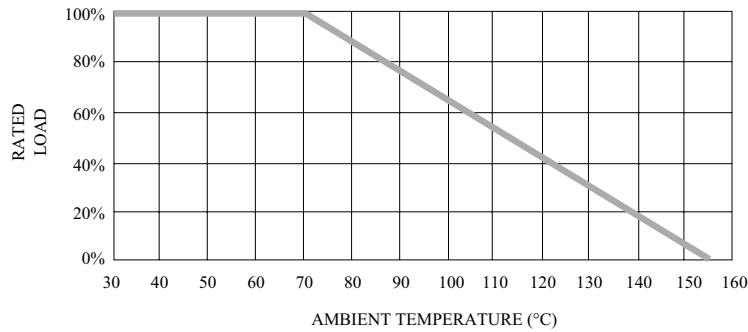

PART NUMBER

Example: HDR25J100KTKZTB5K0

HDR25	J	100K	TKZ	TB5K0
Type	Tolerance	Resistance	TCR	Packaging
	J (5%)	100KΩ 4-character code containing - 3 significant digits 1 letter multiplier <u>MULTIPLIER</u> R = 1 K = 10 ³ M = 10 ⁶ G = 10 ⁹	3-character code TKZ = Default Product Temperature Coefficient. Information of typical product temperature coefficient can be found in the Technical Summary section of the datasheet.*	5-character code TB = Tape Box (pieces per box) HDR20 5K0 = 5,000 HDR25/51 2K0 = 2,000 HDR100 1K0 = 1,000 HDR200 500 = 500

* For the availabilities of non-default temperature coefficient, please check with us. Reference for TCR letter codes can be found in section (4) of Part Number Construction in the Appendices.

TECHNICAL SUMMARY

Characteristics	Limits
Dielectric Withstanding Voltage, VAC or DC	HDR20: 300 HDR25: 500 HDR51: 700 HDR100/HDR200: 1000
Temperature Coefficient, PPM/°C*	±300, ±750, ±1500
Operating Temperature Range, °C	-55 ~ +155 (-55~+200 for flameproof coating)
Insulation Resistance, MΩ	>10 ⁴
PCS/10 ⁹ device hours	<1

* Not applicable to all resistance values. Please check with us regarding the PPM of specific resistance value(s).

■ PERFORMANCE SPECIFICATIONS

Characteristics	Test Conditions	Limits		
Short Time Over Load	IEC 60115-1 4.13 5 seconds 2.5x rated voltage (not over max. overload voltage)	±2%		
Load Life In Humidity	IEC 60115-1 4.24 56 days rated load at (40±2)°C and (93±3)% relative humidity	±2%		
Load Life 1,000 hours	IEC 60115-1 4.25.1 Rated load with 1.5 hours ON, 0.5 hours OFF, at (70±2)°C	±2.5%		
Resistance To Soldering Heat	IEC 60115-1 4.18.2 Leads immersed till 3mm from the body in (260±5)°C solder for 10±1 seconds	±1%		
Solderability	IEC 60115-1 4.17.2 Solder area covered after (235±3)°C/(2±0.2) seconds with flux applied	95% Min.		
Vibration	IEC 60115-1 4.22 Six hours in each parallel and axial direction with a simple harmonic motion having an amplitude of 1.52mm and 10 to 2,000 Hz.	±1%		
Thermal Endurance	IEC 60115-1 4.25.3 1000 hours at 155°C without load	±1%		
Thermal Shock	IEC 60115-1 4.19 -55°C 30minutes, +155°C 30minutes, 5 cycles	±2%		
EN60065 (VDE0860) Test	Discharge test:10KV, 1000pF capacitor discharge pulse, 50 times (1 pulse/5 seconds maximum)	20%		
Surge Test	Surge Voltage = $\sqrt{(3600 \times P \times R)}$ DC P is power rating, R is resistance value, surge voltage is not more than listed at right. Surge spec = 1.2/50µs Period = 12 sec Number of surges = 50	HDR20	2.5KV	5%
		HDR25	3.5K V	
		HDR51	5KV	
		HDR100	7KV	
		HDR200	10KV	

*Quality • Reliability
Cost-Down via Technology*

HDR

HDR20

SURGE PERFORMANCE

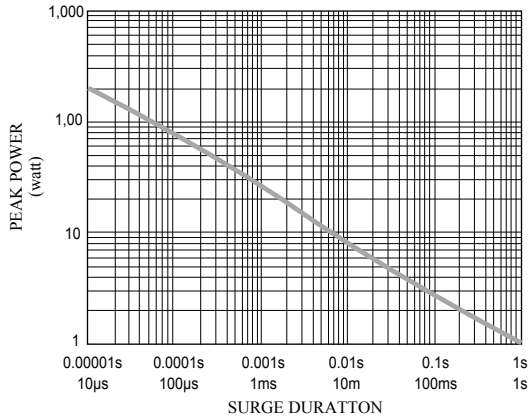

HDR25

SURGE PERFORMANCE

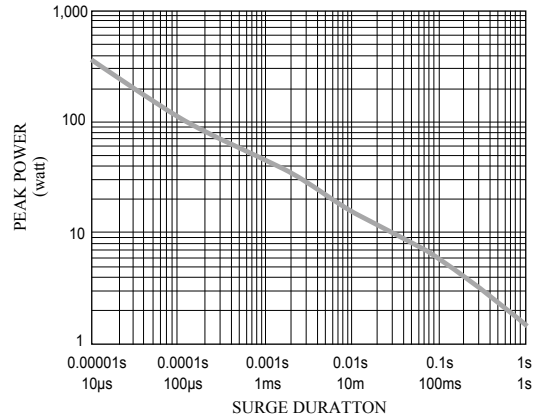

HDR51

SURGE PERFORMANCE

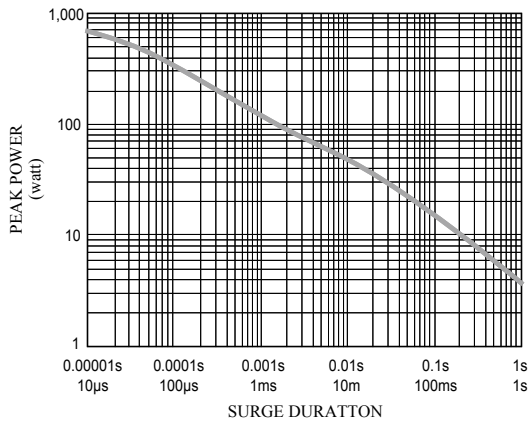

HDR100

SURGE PERFORMANCE

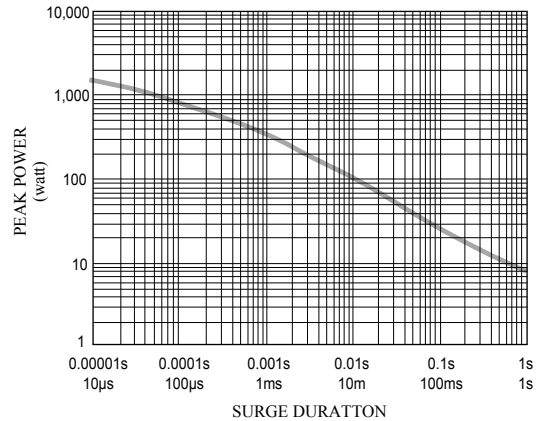

HDR200

SURGE PERFORMANCE

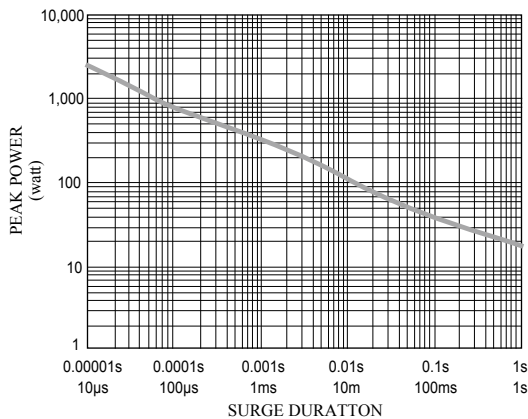

Quality • Reliability
Cost-Down via Technology

HFT

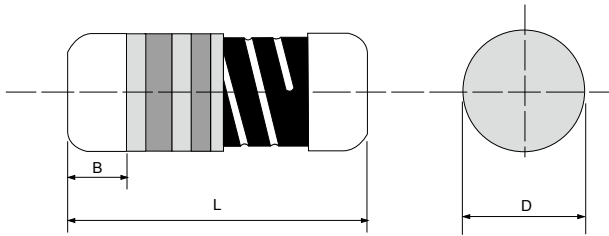

Specifications Per

- IEC 60115-1, IEC 60115-2
- EN 140401-803

Features

- SMD enabled structure
- Superior frequency response
- Excellent solderability termination
- Products meet RoHS requirements and do not contain substances of very high concern identified by European Chemicals Agency

DIMENSIONS

Type	Body Length (L, mm)	Body Diameter (D, mm)	Soldering Spot (B, mm)	Net Weight Per 1000 pcs
HFT204	3.52 ± 0.08	1.35 ± 0.1	0.6 Min.	17 grams
HFT207	5.90 ± 0.20	2.20 ± 0.1	1.0 Min.	66 grams

GENERAL SPECIFICATIONS

Type	Power Rating (at 70°C)	Maximum Working Voltage	Maximum Overload Voltage	Minimum Resistance	Maximum Resistance	Resistance Tolerance	Available Resistance Values
HFT204	1/4W	200V	400V	24.9Ω	75Ω	±0.1%~±1%	E-24/E-96
HFT207	1/3W	300V	500V	24.9Ω	75Ω	±0.1%~±1%	E-24/E-96

Special size, values, and specifications not listed available on special order.

POWER DERATING CURVE

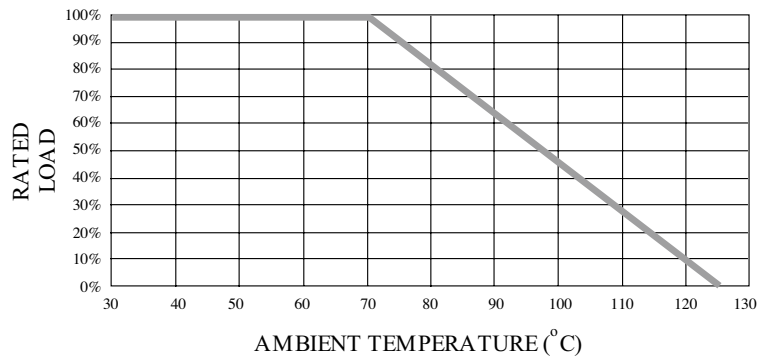

Quality • Reliability
Cost-Down via Technology

■ PART NUMBER

Example: HFT204F50R0TKZTR3K0

HFT204	F	50R0	TKZ	TR3K0
Type	Tolerance*	Resistance	TCR	Packaging
	B (0.1%) C (0.25%) D(0.5%) F (1%)	50Ω 4-character code containing - 3 significant digits 1 letter multiplier <u>MULTIPLIER</u> R = 1 K = 10 ³ M = 10 ⁶ G = 10 ⁹	3-character code TKZ = Default Product Temperature Coefficient. Information of typical product temperature coefficient can be found in the Technical Summary section of the datasheet.**	5-character code TR = Tape Reel (pieces per reel) <u>HFT204</u> 3K0 = 3,000 6K0 = 6,000*** 10K = 10,000*** <u>HFT207</u> 2K0 = 2,000 6K0 = 6,000*** 10K = 10,000***

* Listed values may not be applicable to all resistance values. Please check with us before placing order.

** For the availabilities of non-default temperature coefficient, please check with us. Reference for TCR letter codes can be found in section (4) of Part Number Construction in the Appendices.

*** upon request

■ TECHNICAL SUMMARY

Characteristics	Limits	
Dielectric Withstanding Voltage, VAC or DC	HFT204: 200VAC HFT207: 500VAC	
Temperature Coefficient, PPM / °C*	±50, ±100	
Operating Temperature Range, °C	-55 ~ +125	
Film Temperature, °C	HFT204	HFT207
	125	125
Insulation Resistance, MΩ	>10 ⁴	
Tin Whisker (JESD201 Temperature Cycling & High Temp. /Humidity Storage), μm	<5	

* Not applicable to all resistance values. Please check with us regarding the PPM of specific resistance value(s).

■ COVER TAPE PEELING SPECIFICATION

Recommended peeling force:

HFT204, HFT207: 50±5gf

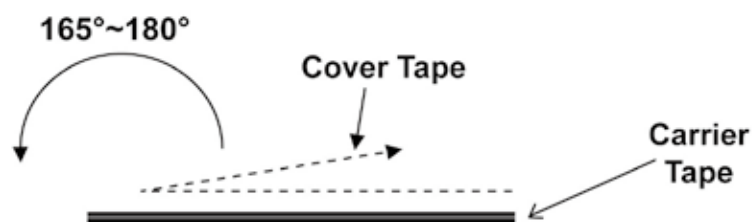

Quality • Reliability
Cost-Down via Technology

■ FUNCTIONAL PERFORMANCE

RF-BEHAVIOR

HFT

IZI/R for HFT204 MELF resistors

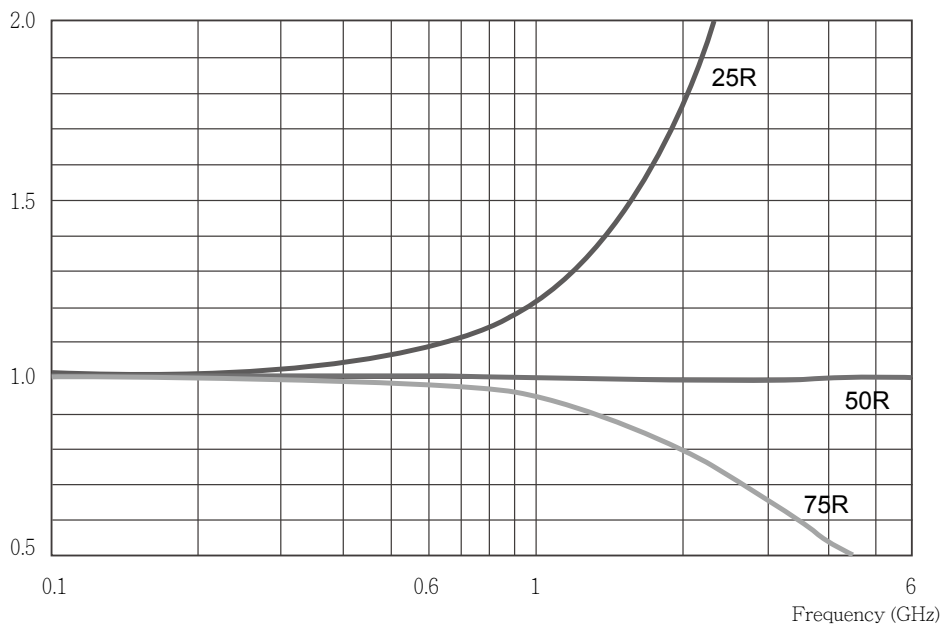

IZI/R for HFT207 MELF resistors

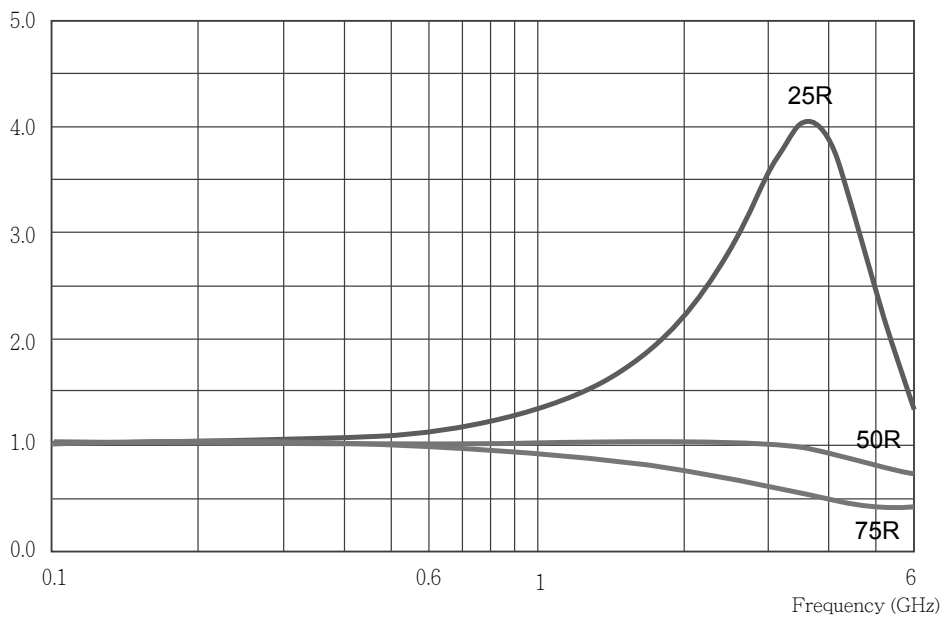

*Quality • Reliability
Cost-Down via Technology*

■ **FUNCTIONAL PERFORMANCE**

VSWR

HFT204 25R MFLF Resistor

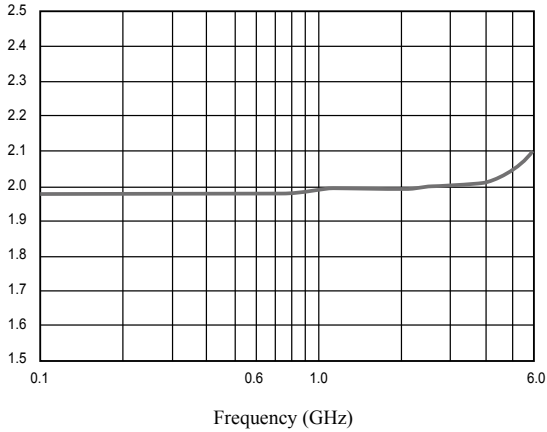

HFT207 25R MFLF Resistor

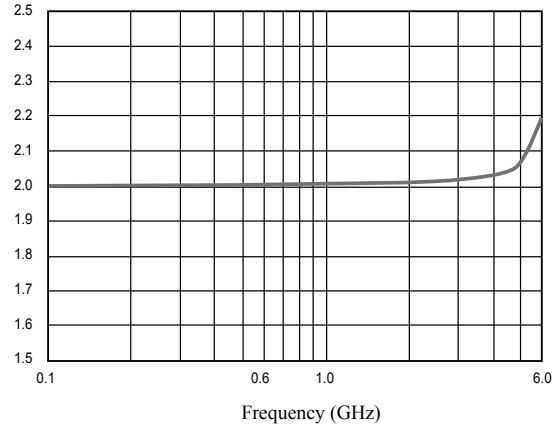

HFT204 50R MFLF Resistor

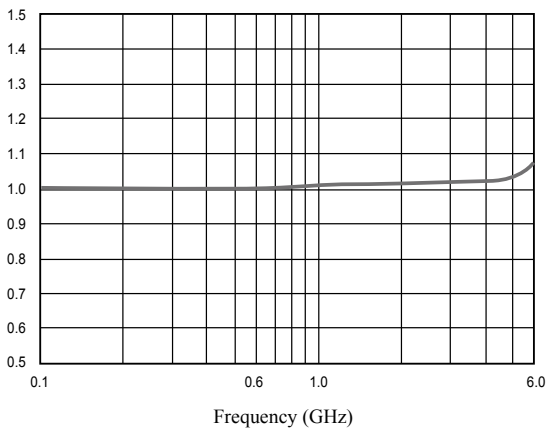

HFT207 50R MFLF Resistor

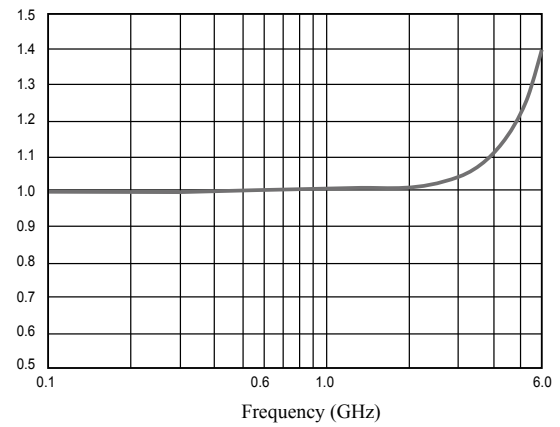

HFT204 75R MFLF Resistor

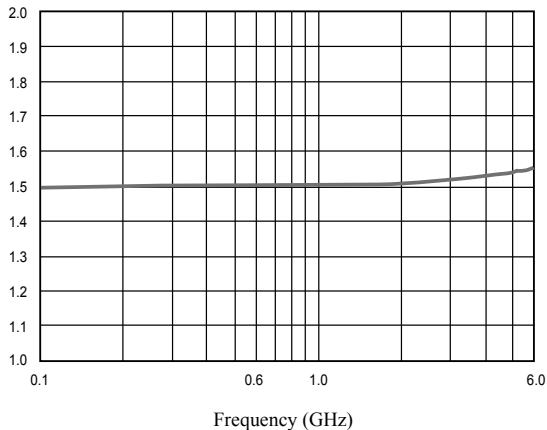

HFT207 75R MFLF Resistor

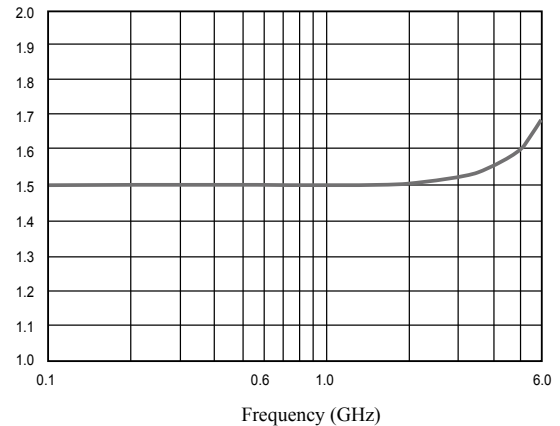

HFT

■ PERFORMANCE SPECIFICATIONS

Characteristics	Test Conditions	Limits
Short Time Overload	IEC 60115-1 4.13 5 seconds 2.5x rated voltage (not over max. overload voltage)	±0.5%
Load Life In Humidity	IEC 60115-1 4.24 56 days rated load at (40±2)°C and (93±3)% relative humidity	±1%
Load Life 1,000 hours	IEC 60115-1 4.25.1 Rated load with 1.5 hours ON, 0.5 hours OFF, at (70±2)°C	±1%
Periodic Electric Overload	IEC 60115-1 4.39 3.9x rated voltage (not over max. overload voltage) with 0.1s ON, 2.5s OFF for 1,000 cycles	±1%
Resistance To Soldering Heat	IEC 60115-1 4.18.2 Dip the resistor into a solder bath measured (260±5)°C and hold it for a 10±1 seconds	±0.5%
Solderability	IEC 60115-1 4.17.2 Solder area covered after (235±3)°C/(2±0.2) seconds with flux applied	95% Min.
Vibration	IEC 60115-1 4.22 Six hours in each parallel and axial direction with a simple harmonic motion having an amplitude of 1.52mm and 10 to 2,000 Hz.	±1%
Thermal Endurance	IEC 60115-1 4.25.3 1000 hours at 125°C without load	±0.5%
Thermal Shock	IEC 60115-1 4.19 -55°C 30minutes, +125°C 30minutes, 5 cycles	±0.5%
Single pulse high voltage overload	IEC 60115-1 4.27 10 pulses of 10/700µs at 10x rated voltage (not over max. overload voltage) with interval of 60 sec.	±1%
Electrostatic discharge (Human body model)	IEC 60115-1 4.38 3 positive & 3 negative discharges with 2KV for HFT204 or 4KV for HFT207	±2%
Climatic test	IEC 60115-1 4.23 4.23.2 - dry heat: 16 hours 125°C 4.23.3 - damp heat: 24 hours 55°C with 95% relative humidity 4.23.4 - cold: 2 hours -55°C 4.23.5 - negative air pressure: 2 hour 8.5KPa at (25±10)°C 4.23.6 - damp heat cyclic: 5 days 55°C with 95% relative humidity 4.23.7 - DC load: rated voltage at -55°C and 125°C each 1 Min.	±1%
Bending test	IEC 60115-1 4.33 Pressing depth 2mm, 3 times	±0.25%
Flammability	IEC 60115-1 4.35 Needle flame test 10s	No burning after 30s

■ SUGGESTED PAD LAYOUT

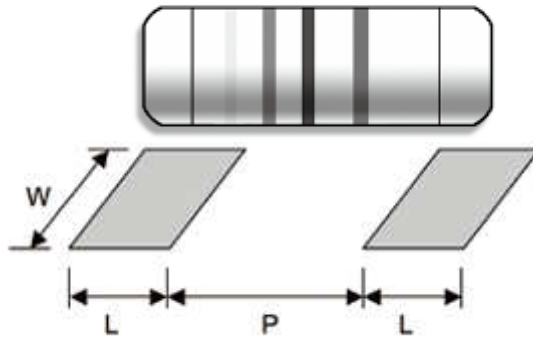

Type	Soldering Mode	Pad Length (L, mm, Min.)	Pad Spacing (P, mm)	Pad Width (W, mm, Min.)
HFT204	Reflow	1.0	2.0 ± 0.2	1.6
	Wave	1.2	2.0 ± 0.2	1.6
HFT207	Reflow	2.0	3.0 ± 0.3	3.0
	Wave	2.5	3.0 ± 0.3	3.0

For better heat dissipation / lower heat resistance, increase W & L.

HVM High Voltage MELF Resistor

Quality • Reliability
Cost-Down via Technology

HVM

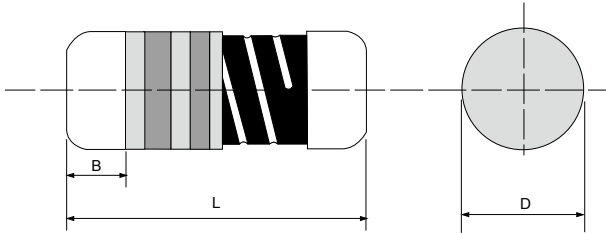

Specifications Per

- IEC 60115-1

Features

- Handles much higher working voltage than general purpose resistors
- Pure tin-plated termination for excellent solderability
- SMD enabled structure
- Anti-surge feature available
- Products meet RoHS requirements and do not contain substances of very high concern identified by European Chemicals Agency

■ DIMENSIONS

Type	Body Length (L, mm)	Body Diameter (D, mm)	Soldering Spot (B, mm)	Net Weight Per 1000 pcs
HVM16	3.52 ± 0.08	1.35 ± 0.1	0.6 Min.	17 grams
HVM25	5.90 ± 0.20	2.20 ± 0.1	1.0 Min.	66 grams
HVM50	8.50 ± 1.00	3.00 ± 0.2	1.3 Min.	186 grams
HVM100	10.5 ± 1.00	4.00 ± 0.5	1.6 Min.	446 grams
HVM200	12.6 ± 1.50	4.60 ± 0.7	1.8 Min.	750 grams
HVM300	14.6 ± 2.00	5.10 ± 1.0	2.0 Min.	1000 grams

■ GENERAL SPECIFICATIONS

Type	Power Rating (at 70°C)	Maximum Working Voltage	Maximum Overload Voltage	Minimum Resistance	Maximum Resistance	Resistance Tolerance	Available Resistance Values
HVM16	1/6W	600V	1,250V DC 900V RMS	56KΩ	22MΩ	±1%~±5%	E-24/E-96
HVM25	1/4W	1,250V DC 900V RMS	2,400V DC 1,800V RMS	91KΩ	24MΩ	±1%~±5%	E-24/E-96
HVM50	1/2W	2,800V DC 2,000V RMS	5,600V DC 4,000V RMS	100KΩ	33MΩ	±1%~±5%	E-24/E-96
HVM100	1W	4,200V DC 3,000V RMS	8,400V DC 6,000V RMS	100KΩ	68MΩ	±1%~±5%	E-24/E-96
HVM200	2W	6,300V DC 4,500V RMS	11,200V DC 8,000V RMS	100KΩ	68MΩ	±1%~±5%	E-24/E-96
HVM300	3W	8,400V DC 6,000V RMS	14,000V DC 10,000V RMS	100KΩ	68MΩ	±1%~±5%	E-24/E-96

Special sizes, values, and specifications not listed available on special order.

Quality • Reliability
Cost-Down via Technology

HVM

POWER DERATING CURVE

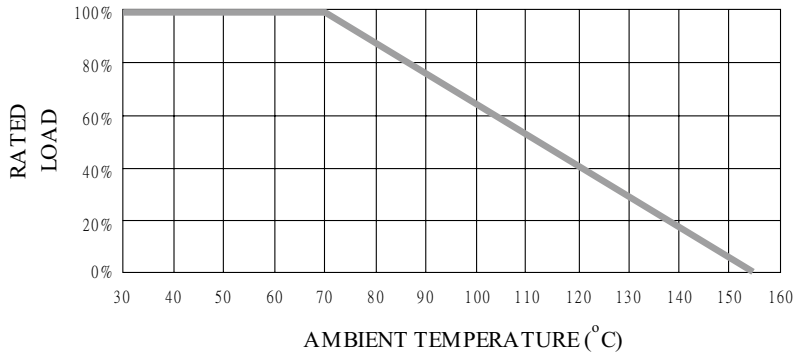

PART NUMBER

Example: HVM100J910KTKZTR2K0

HVM100	J	910K	TKZ	TR2K0
Type	Tolerance*	Resistance	TCR	Packaging
	F (1%) G (2%) J (5%)	910KΩ 4-character code containing - 3 significant digits 1 letter multiplier MULTIPLIER R = 1 K = 10 ³ M = 10 ⁶ G = 10 ⁹	3-character code TKZ = Default Product Temperature Coefficient. Information of typical product temperature coefficient can be found in the Technical Summary section of the datasheet.**	5-character code TR = Tape Reel (pieces per reel) HVM16 3K0 = 3,000 6K0 = 6,000*** 10K = 10,000*** HVM25 2K0 = 2,000 6K0 = 6,000*** 10K = 10,000*** HVM50 2K5 = 2,500 HVM100 2K0 = 2,000 BK = Bulk HVM200/HVM300 BK + Quantity

* Listed values may not be applicable to all resistance values. Please check with us before placing order.

** For the availabilities of non-default temperature coefficient, please check with us. Reference for TCR letter codes can be found in section (4) of Part Number Construction in the Appendices.

*** upon request

TECHNICAL SUMMARY

Characteristics	Limits
Dielectric Withstanding Voltage, VAC or DC	HVM16: 300 HVM25: 500 HVM50: 700 HVM100, HVM200, HVM300: 1000
Temperature Coefficient, PPM / °C*	±200, ±400, ±800, ±1200
Operating Temperature Range, °C	-55 ~ +155
Insulation Resistance, MΩ	>10 ⁴
Failure Rate in Time, pcs / 10 ⁹ device hours	< 5
Tin Whisker (JESD201 Temperature Cycling & High Temp. /Humidity Storage), μm	< 5

* Not applicable to all resistance values. Please check with us regarding the PPM of specific resistance value(s).

PERFORMANCE SPECIFICATIONS

Characteristics	Test Conditions	Limits
Short Time Overload	IEC 60115-1 4.13 2 seconds 2.5x rated voltage (not over max. overload voltage)	±2%
Load Life In Humidity	IEC 60115-1 4.24 56 days rated load at (40±2)°C and (93±3)% relative humidity	±3%
Load Life 1,000 hours	IEC 60115-1 4.25.1 Rated load with 1.5 hours ON, 0.5 hours OFF, at (70±2)°C	±3%
Periodic Electric Overload	IEC 60115-1 4.39 3.9x rated voltage (not over max. overload voltage) with 0.1s ON, 2.5s OFF for 1,000 cycles	±2.5%
Resistance To Soldering Heat	IEC 60115-1 4.18.2 Dip the resistor into a solder bath measured (260±5)°C and hold it for a 10±1 seconds	±1%
Solderability	IEC 60115-1 4.17.2 Solder area covered after (235±3)°C/(2±0.2) seconds with flux applied	95% Min.
Vibration	IEC 60115-1 4.22 Six hours in each parallel and axial direction with a simple harmonic motion having an amplitude of 0.75mm and 10 to 500 Hz.	±1%
Thermal Endurance	IEC 60115-1 4.25.3 1000 hours at 155°C without load	±1%
Thermal Shock	IEC 60115-1 4.19 -55°C 30minutes, +155°C 30minutes, 5 cycles	±2%
Single pulse high voltage overload	IEC 60115-1 4.27 10 pulses of 10/700μs at 10x rated voltage (not over max. overload voltage) with interval of 60 sec.	±2%
Electrostatic discharge (Human body model)	IEC 60115-1 4.38 3 positive & 3 negative discharges with 4KV source	±2.5%
Climatic test	IEC 60115-1 4.23 4.23.2 - dry heat: 16 hours 155°C 4.23.3 - damp heat: 24 hours 55°C with 95% relative humidity 4.23.4 - cold: 2 hours -55°C 4.23.5 - negative air pressure: 2 hour 8.5KPa at (25±10)°C 4.23.6 - damp heat cyclic: 5 days 55°C with 95% relative humidity 4.23.7 - DC load: rated voltage at -55°C and 155°C each 1 Min.	±2%
Bending test	IEC 60115-1 4.33 Pressing depth 2mm, 3 times	±1%
Flammability	IEC 60115-1 4.35 Needle flame test 10s	No burning after 30s

Quality • Reliability
Cost-Down via Technology

HVM

■ SUGGESTED PAD LAYOUT

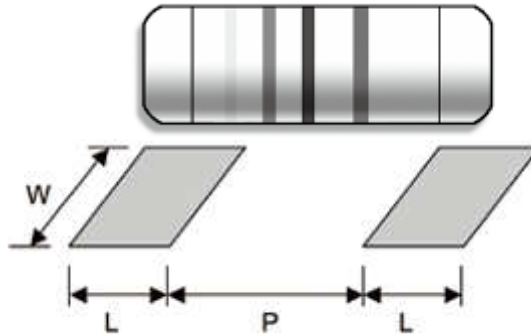

Type	Soldering Mode	Pad Length (L, mm, Min.)	Pad Spacing (P, mm)	Pad Width (W, mm, Min.)
HVM16	Reflow	1.0	2.0 ± 0.2	1.6
	Wave	1.2	2.0 ± 0.2	1.6
HVM25	Reflow	2.0	3.0 ± 0.3	3.0
	Wave	2.5	3.0 ± 0.3	3.0
HVM50	Reflow	3.0	4.9 ± 0.3	3.7
	Wave	3.5	4.8 ± 0.3	4.0
HVM100	Reflow (Not recommended)	4.0	6.2 ± 0.4	4.5
	Wave	4.5	6.0 ± 0.4	5.0
HVM200	Reflow (Not recommended)	4.5	8.0 ± 0.4	5.0
	Wave	5.0	7.7 ± 0.4	5.5
HVM300	Reflow (Not recommended)	5.0	9.3 ± 0.4	5.5
	Wave	5.0	9.0 ± 0.4	5.5

For better heat dissipation / lower heat resistance, increase W & L.

■ COVER TAPE PEELING SPECIFICATION

Recommended peeling force:

HVM16, HVM25: 50±5gf HVM50, HVM100: 70±10gf

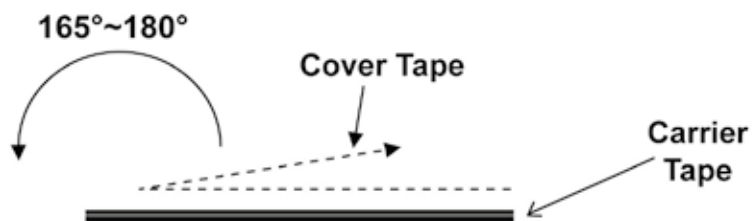

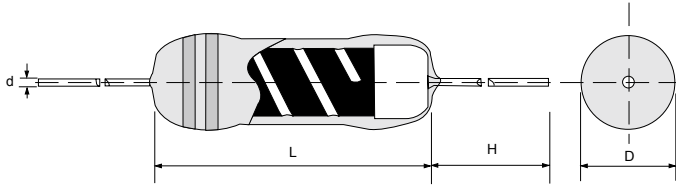

Features

- Special conductive film withstands high voltage
- Maximum working voltage far over that of general-purpose resistors
- Suitable for applications such as TV's, high voltage power supply, and high voltage detection.
- Entire series is VDE0860 (EN60065) approved under license number 40011593
- Products meet RoHS requirements and do not contain substances of very high concern identified by European Chemicals Agency

DIMENSIONS

Type	Body Length (L, mm)	Body Diameter (D, mm)	Lead Wire Length (H, mm)	Lead Wire Diameter (d, mm)	Net Weight Per 1000Pcs
HVR25	6.50 ± 1.0	2.6 ± 0.3	26 ± 3.0	0.55 ± 0.03	300 Grams
HVR50	8.80 ± 1.0	3.2 ± 0.2	28 ± 3.0	0.60 ± 0.03	340 Grams
HVR100	15.5 ± 1.0	5.5 ± 0.5	30 ± 3.0	0.80 ± 0.03	1200 Grams
HVR200	19.0 ± 1.0	6.0 ± 0.5	30 ± 3.0	0.80 ± 0.03	1620 Grams
HVR300	24.0 ± 1.0	8.0 ± 0.5	30 ± 3.0	0.80 ± 0.03	3100 Grams

GENERAL SPECIFICATIONS

Type	Power Rating (at 70°C)	Maximum Working Voltage	Maximum Overload Voltage	Minimum Resistance	Maximum Resistance	Resistance Tolerance	Available Resistance Values
HVR25	1/4W	1.6KV DC 1150V RMS	3KV DC 2KV RMS	91KΩ	24MΩ	± 5%	E-24
						± 1%	E-24/E-96
HVR50	1/2W	3.5KV DC 2.5KV RMS	7KV DC 5KV RMS	100KΩ	33MΩ	± 5%	E-24
						± 1%	E-24/E-96
HVR100	1W	10KV DC 7KV RMS	20KV DC 14KV RMS	100KΩ	68MΩ	± 5%	E-24
						± 1%	E-24/E-96
HVR200	2W	11KV DC 8KV RMS	20KV DC 15KV RMS	100KΩ	100MΩ	± 5%	E-24
						± 1%	E-24/E-96
HVR300	3W	12KV DC 8.5KV RMS	20KV DC 15KV RMS	100KΩ	100MΩ	± 5%	E-24
						± 1%	E-24/E-96

Other sizes and values available on request.

■ PART NUMBER

Example: HVR200J10M0TKZTB500

HVR200	J	10M0	TKZ	TB500
Type	Tolerance*	Resistance	TCR	Packaging
	F (1%) G (2%) J (5%)	10MΩ 4-character code containing - 3 significant digits 1 letter multiplier MULTIPLIER R = 1 K = 10 ³ M = 10 ⁶ G = 10 ⁹	3-character code TKZ = Default Product Temperature Coefficient. Information of typical product temperature coefficient can be found in the Technical Summary section of the datasheet.**	5-character code TB = Tape Box (pieces per box) <u>HVR25/HVR50</u> 2K0 = 2,000 <u>HVR100/200</u> 500 = 500 <u>HVR300</u> 250 = 250

* Listed values may not be applicable across the product series/all resistance values. Please check with us before placing order.

** For the availabilities of non-default temperature coefficient, please check with us. Reference for TCR letter codes can be found in section (4) of Part Number Construction in the Appendices.

■ TECHNICAL SUMMARY

Characteristics	Limits
Power Derating, Linear	100% at < 70°C, zero at 155°C
Dielectric Withstanding Voltage, VAC or DC	HVR25: 500
	HVR50, HVR100: 700
	HVR200: 800
	HVR300: 1000
Temperature Coefficient, PPM / °C*	±200, ±400, ±800
Operating Temperature Range, °C	-55 ~ +155
Insulation Resistance, MΩ	>10 ⁴

* Not applicable to all resistance values. Please check with us regarding the PPM of specific resistance value(s).

■ PERFORMANCE SPECIFICATIONS

Characteristics	Test Conditions	Limits	
Short Time Over Load	IEC 60115-1 4.13 5 seconds 2.5x rated voltage (not over max. overload voltage)	± 1%	
Load Life In Humidity	IEC 60115-1 4.24 56 days rated load at (40±2)°C and (93±3)% relative humidity	± 5%	
Load Life 1,000 hours	IEC 60115-1 4.25.1 Rated load with 1.5 hours ON, 0.5 hours OFF, at (70±2)°C	± 5%	
Resistance To Soldering Heat	IEC 60115-1 4.18.2 Leads immersed till 3mm from the body in (260±5)°C solder for 10±1 seconds	± 1%	
Solderability	IEC 60115-1 4.17.2 Solder area covered after (235±3)°C/(2±0.2) seconds with flux applied	95% Min.	
Vibration	IEC 60115-1 4.22 Six hours in each parallel and axial direction with a simple harmonic motion having an amplitude of 0.75mm and 10 to 500 Hz.	± 1%	
Thermal Endurance	IEC 60115-1 4.25.3 1000 hours at 155°C without load	± 1%	
Thermal Shock	IEC 60115-1 4.19 -55°C 30 minutes, +155°C 30minutes, 5 cycles	± 1%	
Surge Test	Surge voltage = $\sqrt{(100 \times P \times R)}$ DC P is power rating, R is resistance value, surge voltage is not more than listed at right. Surge duration = 50ns Period = 1 sec Number of surges = 5000	HVR25: 10KV	5%
		HVR50: 30KV	
		HVR100: 40KV	
		HVR200: 40KV	
		HVR300: 40KV	

Firstohm®



HVR - High Voltage Resistor (High Power)

Quality • Reliability
Cost-Down via Technology

HVR

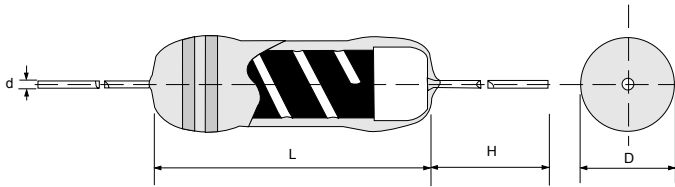

Features

- Special conductive film withstands voltage far over the maximum working voltage of general-purpose resistors.
- Suitable for applications such as TV's, high voltage power supply, and high voltage detection.
- Products meet RoHS requirements and do not contain substances of very high concern identified by European Chemicals Agency

DIMENSIONS

Type	Body Length (L, mm)	Body Diameter (D, mm)	Lead Wire Length (H, mm)	Lead Wire Diameter (d, mm)	Net Weight Per 1000 Pcs
HVR1000	66.0 ± 1.5	8 ± 0.5	39 ± 3.0	0.8 ± 0.03	8200 Grams
HVR1500	66.0 ± 1.5	8 ± 0.5	39 ± 3.0	0.8 ± 0.03	8200 Grams

GENERAL SPECIFICATIONS

Type	Power Rating (at 70°C)	Maximum Working Voltage	Maximum Overload Voltage	Minimum Resistance	Maximum Resistance	Resistance Tolerance	Available Resistance Values
HVR1000	10W	35KV DC	50KV DC	100KΩ	100MΩ	± 5%	E-24
						± 1%	E-96
HVR1500	15W	35KV DC	50KV DC	100KΩ	100MΩ	± 5%	E-24
						± 1%	E-96

Other sizes and values available on request.

POWER DERATING CURVE

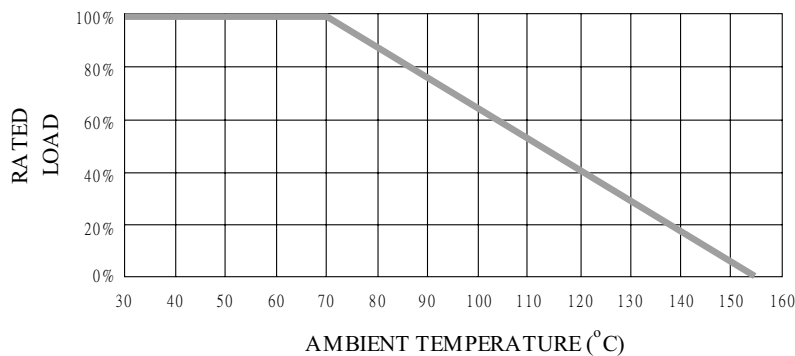

TECHNICAL SUMMARY

Characteristics	Limits
Dielectric Withstanding Voltage, VAC or DC	1000
Temperature Coefficient, PPM / °C*	±800
Operating Temperature Range, °C	-55 ~ +155
Insulation Resistance, MΩ	>10 ⁴

* Not applicable to all resistance values. Please check with us regarding the PPM of specific resistance value(s).

■ PART NUMBER

Example: HVR1000J100KTKZBK100

HVR1000	J	100K	TKZ	BK100
Type	Tolerance*	Resistance	TCR	Packaging
	F (1%) G (2%) J (5%)	100KΩ 4-character code containing - 3 significant digits 1 letter multiplier MULTIPLIER R = 1 K = 10 ³ M = 10 ⁶ G = 10 ⁹	3-character code TKZ = Default Product Temperature Coefficient. Information of typical product temperature coefficient can be found in the Technical Summary section of the datasheet.**	Bulk 100 pieces 5-character code BK = Bulk BK + Quantity

* Listed values may not be applicable across the product series/all resistance values. Please check with us before placing order.

** For the availabilities of non-default temperature coefficient, please check with us. Reference for TCR letter codes can be found in section (4) of Part Number Construction in the Appendices.

■ PERFORMANCE SPECIFICATIONS

Characteristics	Test Conditions	Limits
Short Time Over Load	IEC 60115-1 4.13 5 seconds 2.5x rated voltage (not over max. overload voltage)	±2%
Load Life In Humidity	IEC 60115-1 4.24 56 days rated load at (40±2)°C and (93±3)% relative humidity	±5%
Load Life 1,000 hours	IEC 60115-1 4.25.1 Rated load with 1.5 hours ON, 0.5 hours OFF, at (70±2)°C	±5%
Resistance To Soldering Heat	IEC 60115-1 4.18.2 Leads immersed till 3mm from the body in (260±5)°C solder for 10±1 seconds	±1%
Solderability	IEC 60115-1 4.17.2 Solder area covered after (235±3)°C/(2±0.2) seconds with flux applied	95% Min.
Vibration	IEC 60115-1 4.22 Six hours in each parallel and axial direction with a simple harmonic motion having an amplitude of 1.52mm and 10 to 2,000 Hz.	±1%
Thermal Endurance	IEC 60115-1 4.25.3 1000 hours at 155°C without load	±1%
Thermal Shock	IEC 60115-1 4.19 -55°C 30minutes, +155°C 30minutes, 5 cycles	±2%
Surge Test	Surge voltage = $\sqrt{(100 \times P \times R)}$ DC P is power rating, R is resistance value, surge voltage is not more than 80KV Surge duration = 50ns Period = 1 sec Number of surges = 5000	5%

Quality • Reliability
Cost-Down via Technology

IG

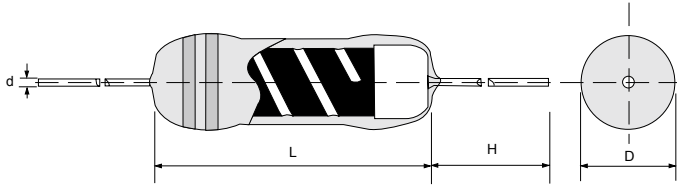

Specifications Per

- IEC 60115-1
- MIL-R-10509

Features

- Special coating technique to ensure fast ignition
- Color code per MIL & EIA standards
- Special conductive film to fuse at high temperature
- Auto cut-off after fusing/no sustaining fire hazard
- Special tin-plated electrolytic copper lead wire for optimal ease of soldering and mounting
- Products meet RoHS requirements and do not contain substances of very high concern identified by European Chemicals Agency

DIMENSIONS

Type No.	Body Length (L, mm)	Body Diameter (D, mm)	Lead Wire Length (H, mm)	Lead Wire Diameter (d, mm)	Net Weight Per 1000Pcs
IG16	3.15 ± 0.2	1.7 ± 0.1	28 ± 3.0	0.45 ± 0.02	145 Grams

GENERAL SPECIFICATIONS

Type	Power Rating (at 70°C)	Maximum Working Voltage	Maximum Overload Voltage	Minimum Resistance	Maximum Resistance	Resistance Tolerance	Available Resistance Values
IG16	1/6W	200V	400V	1Ω	150Ω	±5%	E-24

Other sizes and values available on request.

POWER DERATING CURVE

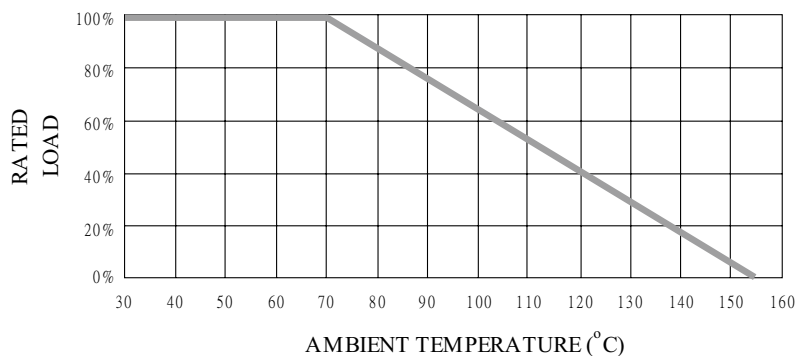

■ TAPING/PACKING SPECIFICATIONS

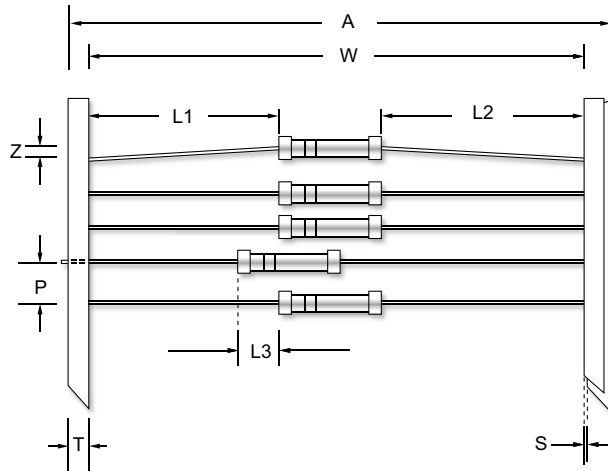

Unit (mm)

Type No.	A Max.	L1-L2 (Max.)	L3 (Max.)	P ±0.5	S (Max.)	T ±0.5	W ±1.5	Z (Max.)
IG16	65	±1.0	0.5	5.0	0.8	6.0	52.5	1.2

Type No.	Packing Type	R16	R25
Minimum Packing QTY (pcs)	Ammo pack	5000	5000

■ PART NUMBER

Example: IG16J24R0TKZTB5K0

IG16	J	24R0	TKZ	TB5K0
Type	Tolerance	Resistance	TCR	Packaging
	J (5%)	24Ω 4-character code containing - 3 significant digits 1 letter multiplier <u>MULTIPLIER</u> R = 1 K = 10 ³ M = 10 ⁶ G = 10 ⁹	3-character code TKZ = Default Product Temperature Coefficient. Information of typical product temperature coefficient can be found in the Technical Summary section of the datasheet.*	5-character code TB = Tape Box (pieces per box) IG16 5K0 = 5,000

* For the availabilities of non-default temperature coefficient, please check with us. Reference for TCR letter codes can be found in section (4) of Part Number Construction in the Appendices.

■ TECHNICAL SUMMARY

Characteristics	Limits
Ignition Power, W	>21
Ignition Time, secon(s)	<1.5
Temperature Coefficient, PPM / °C*	±200 PPM/°C
Insulation Resistance, MΩ	>10 ⁴
Operating Temperature Range, °C	-55 ~ +155

* Not applicable to all resistance values. Please check with us regarding the PPM of specific resistance value(s).

■ PERFORMANCE SPECIFICATIONS

Characteristics	Test Conditions	Limits
Short Time Over Load	IEC 60115-1 4.13 5 seconds 2.5x rated voltage (not over max. overload voltage)	±0.5%
Load Life In Humidity	IEC 60115-1 4.24 56 days rated load at (40±2)°C and (93±3)% relative humidity	±2%
Load Life 1,000 hours	IEC 60115-1 4.25.1 Rated load with 1.5 hours ON, 0.5 hours OFF, at (70±2)°C	±2%
Resistance To Soldering Heat	IEC 60115-1 4.18.2 Leads immersed till 3mm from the body in (260±5)°C solder for 10±1 seconds	±0.5%
Solderability	IEC 60115-1 4.17.2 Solder area covered after (235±3)°C/(2+0.2) seconds with flux applied	95% Min.
Vibration	IEC 60115-1 4.22 Six hours in each parallel and axial direction with a simple harmonic motion having an amplitude of 1.52mm and 10 to 2,000 Hz.	±0.5%
Thermal Endurance	IEC 60115-1 4.25.3 1000 hours at 155°C without load	±1%
Thermal Shock	IEC 60115-1 4.19 -55°C 30minutes, +155°C 30minutes, 5 cycles	±0.5%

Firstohm®



M-Series Metal Film Fixed Resistor

Quality • Reliability
Cost-Down via Technology

M-Series

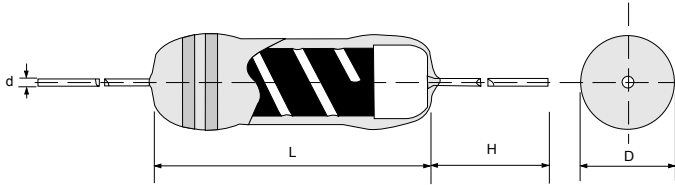

Specifications Per

- IEC 60115-1
- MIL-R-10509

Features

- Conformal multi-layer coating
- Color code per MIL & EIA standards
- Special tin-plated electrolytic copper lead wire
- Products meet RoHS requirements and do not contain substances of very high concern identified by European Chemicals Agency

■ DIMENSIONS

Type	Body Length (L, mm)	Body Diameter (D, mm)	Lead Wire Length (H, mm)	Lead Wire Diameter (d, mm)	Net Weight Per 1000Pcs
M16	3.20 ± 1.0	1.9 ± 0.2	28 ± 3.0	0.45 ± 0.02	145 Grams
M20	3.20 ± 1.0	1.9 ± 0.2	28 ± 3.0	0.45 ± 0.02	145 Grams
M25	6.50 ± 1.0	2.4 ± 0.2	26 ± 3.0	0.55 ± 0.03	220 Grams
M207	6.50 ± 1.0	2.4 ± 0.2	26 ± 3.0	0.55 ± 0.03	220 Grams
M51	8.80 ± 1.0	3.2 ± 0.2	26 ± 3.0	0.60 ± 0.03	340 Grams
M100	11.0 ± 1.0	4.5 ± 0.5	26 ± 3.0	0.70 ± 0.03	600 Grams
M200	15.5 ± 1.0	5.5 ± 0.5	26 ± 3.0	0.80 ± 0.03	1200 Grams

■ GENERAL SPECIFICATIONS

Type	Power Rating At 70°C	Maximum Working Voltage	Maximum Overload Voltage	Minimum Resistance	Maximum Resistance	Resistance Tolerance	Available Resistance Values
M16	1/6W	200V	400V	0.1Ω	10MΩ	±5%	E-24
				1Ω	1MΩ	±1%	E-24/E-96
				47Ω	510KΩ	±0.1%~0.5%	E-24/E-192
M20	1/4W	250V	400V	0.1Ω	10MΩ	±5%	E-24
				1Ω	1MΩ	±1%	E-24/E-96
				47Ω	510KΩ	±0.1%~0.5%	E-24/E-192
M25	1/4W	250V	500V	0.1Ω	10MΩ	±5%	E-24
				1Ω	1MΩ	±1%	E-24/E-96
				20Ω	1MΩ	±0.1%~0.5%	E-24/E-192
M207	3/5W	300V	500V	0.1Ω	10MΩ	±5%	E-24
				1Ω	1MΩ	±1%	E-24/E-96
				20Ω	1MΩ	±0.1%~0.5%	E-24/E-192
M51	1/2W	350V	700V	0.1Ω	10MΩ	±5%	E-24
				1Ω	1MΩ	±1%	E-24/E-96
				15Ω	1MΩ	±0.1%~0.5%	E-24/E-192
M100	1W	500V	1000V	0.1Ω	10MΩ	±5%	E-24
				1Ω	1MΩ	±1%	E-24/E-96
				10Ω	1MΩ	±0.1%~0.5%	E-24/E-192
M200	2W	500V	1000V	0.1Ω	10MΩ	±5%	E-24
				1Ω	1MΩ	±1%	E-24/E-96
				10Ω	1MΩ	±0.1%~0.5%	E-24/E-192

Special sizes, values, and specifications not listed available on special order.

TAPING/PACKING SPECIFICATIONS

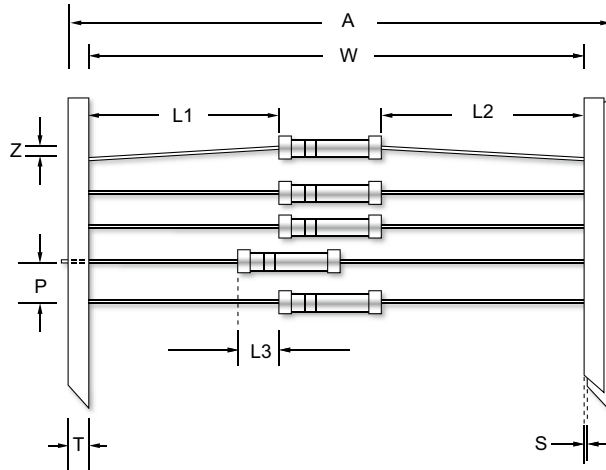

Unit (mm)

Type	A Max.	L1-L2 (Max.)	L3 (Max.)	P ±0.5	S (Max.)	T ±0.5	W ±1.5	Z (Max.)
M16	65	±1.0	0.5	5.0	0.8	6.0	52.5	1.2
M20	65	±1.0	0.5	5.0	0.8	6.0	52.5	1.2
M25	65	±1.0	0.5	5.0	0.8	6.0	52.5	1.2
M207	65	±1.0	0.5	5.0	0.8	6.0	52.5	1.2
M51	65	±1.0	0.5	5.0	0.8	6.0	52.5	1.2
M100	65	±1.0	0.5	5.0	0.8	6.0	52.5	1.2
M200	76	±1.5	1.0	10.0	0.8	6.0	63.5	1.2

Type	Packing Type	M16	M20	M25	M207	M51	M100	M200
Minimum Packing QTY (pcs)	Ammo pack	5000	5000	5000	5000	2000	1000	500

TECHNICAL SUMMARY

Characteristics	Limits	
Dielectric Withstanding Voltage, VAC or DC	M16 / M20 M25 / M207 M51 M100 / M200	300 500 700 1000
Temperature Coefficient, PPM / °C*	±25, ±50, ±100	
Operating Temperature Range, °C	-55 ~ +155	
Insulation Resistance, MΩ	10 ⁴	
Power Derating, linear	100% at 70 °C, down to zero at 155°C	

* Not applicable to all resistance values. Please check with us regarding the PPM of specific resistance value(s).

M-Series Metal Film Fixed Resistor

Quality • Reliability
Cost-Down via Technology

M-Series

■ PART NUMBER

Example: M51F49K9TKRTB2K0

M51	F	49K9	TKR	TB2K0
Type	Tolerance*	Resistance	TCR*	Packaging
	B (0.1%) C (0.25%) D (0.5%) F (1%) G (2%) J (5%)	49.9KΩ 4-character code containing - 3 significant digits 1 letter multiplier MULTIPLIER R = 1 K = 10 ³ M = 10 ⁶ G = 10 ⁹	50ppm 3-character code TKQ = ± 25ppm TKR = ± 50ppm TKS = ± 100ppm	5-character code TB = Tape Box (pieces per box) <u>M16/20/25/207</u> 5K0 = 5,000 <u>M51</u> 2K0 = 2,000 <u>M100</u> 1K0 = 1,000 <u>M200</u> 500 = 500

* Listed values may not be applicable across product types or to all resistance values. Please check with us before placing order.

■ PERFORMANCE SPECIFICATIONS

Characteristics	Test Conditions	Limits
Short Time Over Load	IEC 60115-1 4.13 5 seconds 2.5x rated voltage (not over max. overload voltage)	±0.2%
Load Life In Humidity	IEC 60115-1 4.24 56 days rated load at (40±2)°C and (93±3)% relative humidity	±0.75%
Load Life 1,000 hours	IEC 60115-1 4.25.1 Rated load with 1.5 hours ON, 0.5 hours OFF, at (70±2)°C	±0.75%
Resistance To Soldering Heat	IEC 60115-1 4.18.2 Leads immersed till 3mm from the body in (260±5)°C solder for 10±1 seconds	±0.2%
Solderability	IEC 60115-1 4.17.2 Solder area covered after (235±3)°C/(2±0.2) seconds with flux applied	95% Min.
Vibration	IEC 60115-1 4.22 Six hours in each parallel and axial direction with a simple harmonic motion having an amplitude of 0.75mm and 10 to 500 Hz.	±0.1%
Thermal Endurance	IEC 60115-1 4.25.3 1000 hours at 155°C without load	±0.2%
Thermal Shock	IEC 60115-1 4.19 -55°C 30minutes, +155°C 30minutes, 5 cycles	±0.2%

Firstohm®

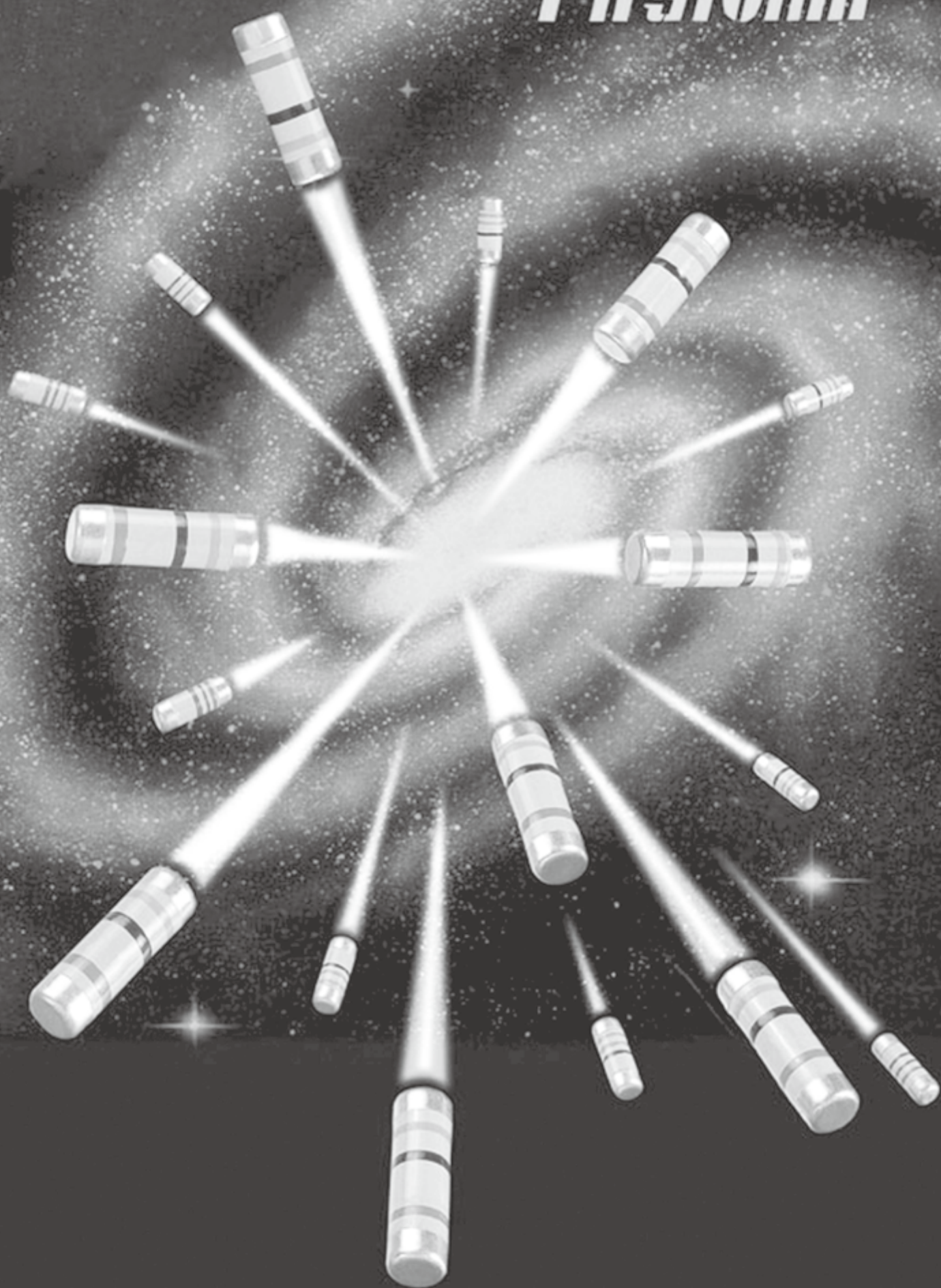

M-Series (S) MINIATURE SIZE Metal Film Fixed Power Resistor

Quality • Reliability
Cost-Down via Technology

M-Series

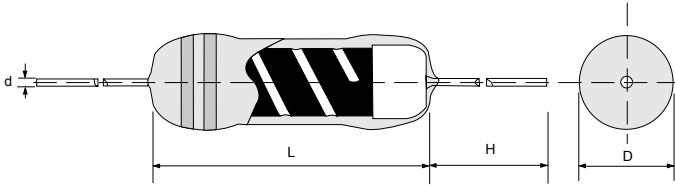

Specifications Per

- IEC 60115-1
- MIL-R-10509

Features

- Conformal multi-layer coating (flame proof coating available)
- Color code per MIL & EIA standards
- Special tin-plated electrolytic copper lead wire
- Products meet RoHS requirements and do not contain substances of very high concern identified by European Chemicals Agency

■ DIMENSIONS

Type	Body Length (L, mm)	Body Diameter (D, mm)	Lead Wire Length (H, mm)	Lead Wire Diameter (d, mm)	Net Weight Per 1000Pcs
M100S	8.80 ± 1.0	3.2 ± 0.2	26 ± 3.0	0.60 ± 0.03	340 Grams
M200S	11.0 ± 1.0	4.5 ± 0.5	26 ± 3.0	0.70 ± 0.03	600 Grams
M300S	15.5 ± 1.0	5.5 ± 0.5	26 ± 3.0	0.80 ± 0.03	1200 Grams

■ GENERAL SPECIFICATIONS

Type	Power Rating At 70°C	Maximum Working Voltage	Maximum Overload Voltage	Minimum Resistance	Maximum Resistance	Resistance Tolerance	Available Resistance Values
M100S	1W	350V	700V	1Ω	1MΩ	±1%	E-24/E-96
M200S	2W	500V	1000V	1Ω	1MΩ	±1%	E-24/E-96
M300S	3W	500V	1000V	1Ω	1MΩ	±1%	E-24/E-96

Special sizes, values, and specifications not listed available on special order.

M-Series (S) MINIATURE SIZE Metal Film Fixed Power Resistor

Quality • Reliability
Cost-Down via Technology

M-Series

■ PART NUMBER

Example: M100SF10K0TKSTB2K0

M100S	F	10K0	TKS	TB2K0
Type	Tolerance	Resistance	TCR*	Packaging
	F (1%)	10KΩ 4-character code containing - 3 significant digits 1 letter multiplier MULTIPLIER R = 1 K = 10 ³ M = 10 ⁶ G = 10 ⁹	100ppm 3-character code TKR = ± 50ppm TKS = ± 100ppm	5-character code TB = Tape Box (pieces per box) M100S 2K0 = 2,000 M200S 1K0 = 1,000 M300S 500 = 500

* Listed values may not be applicable across product types or to all resistance values. Please check with us before placing order.

■ TECHNICAL SUMMARY

Characteristics	Limits	
	Dielectric Withstanding Voltage, V AC or DC	M100S M200S / M300S
Temperature Coefficient, PPM / °C*	±50, ±100	
Operating Temperature Range, °C	-55~+150	
Insulation Resistance, MΩ	10 ⁴	
Power Derating, Linear	100% at 70°C, down to zero at 150°C	

* Not applicable to all resistance values. Please check with us regarding the PPM of specific resistance value(s).

Quality • Reliability
Cost-Down via Technology

M-Series

■ TAPING/PACKING SPECIFICATIONS

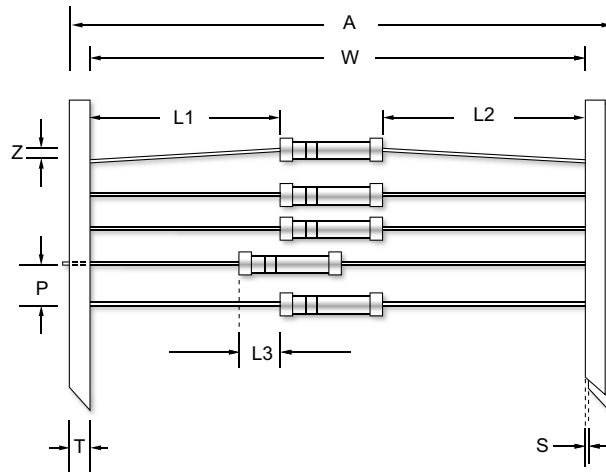

Unit (mm)

Type	A Max.	L1-L2 (Max.)	L3 (Max.)	P ±0.5	S (Max.)	T ±0.5	W ±1.5	Z (Max.)
M100S	65	±1.0	0.5	5.0	0.8	6.0	52.5	1.2
M200S	65	±1.0	0.5	5.0	0.8	6.0	52.5	1.2
M300S	76	±1.5	1.0	10.0	0.8	6.0	63.5	1.2

Type	Packing Type	M100S	M200S	M300S
Minimum Packing QTY (pcs)	Ammo pack	2000	1000	500

M-Series (S) MINIATURE SIZE Metal Film Fixed Power Resistor

Quality • Reliability
Cost-Down via Technology

■ PERFORMANCE SPECIFICATIONS

Characteristics	Test Conditions	Limits
Short Time Over Load	IEC 60115-1 4.13 5 seconds 2.5x rated voltage (not over max. overload voltage)	±2%
Load Life In Humidity	IEC 60115-1 4.24 56 days rated load at (40±2)°C and (93±3)% relative humidity	±2%
Load Life 1,000 hours	IEC 60115-1 4.25.1 Rated load with 1.5 hours ON, 0.5 hours OFF, at (70±2)°C	±1.5%
Resistance To Soldering Heat	IEC 60115-1 4.18.2 Leads immersed till 3mm from the body in (260±5)°C solder for 10±1 seconds	±1%
Solderability	IEC 60115-1 4.17.2 Solder area covered after (235±3)°C/(2±0.2) seconds with flux applied	95% Min.
Vibration	IEC 60115-1 4.22 Six hours in each parallel and axial direction with a simple harmonic motion having an amplitude of 0.75mm and 10 to 500 Hz.	±1%
Thermal Endurance	IEC 60115-1 4.25.3 1000 hours at 150°C without load	±1%
Thermal Shock	IEC 60115-1 4.19 -55°C 30minutes, +150°C 30minutes, 5 cycles	±2%

M-Series (T) MINIATURE SIZE Metal Film Fixed Power Resistor

Quality • Reliability
Cost-Down via Technology

M-Series

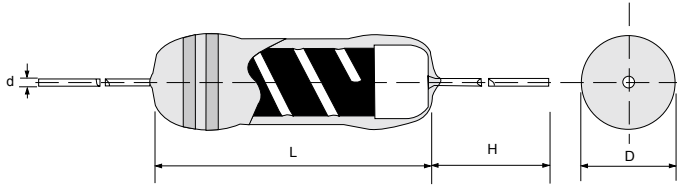

Specifications Per

- IEC 60115-1
- MIL-R-10509

Features

- Conformal multi-layer coating (flame proof coating available)
- Color code per MIL & EIA standards
- Special tin-plated electrolytic copper lead wire
- Products meet RoHS requirements and do not contain substances of very high concern identified by European Chemicals Agency

DIMENSIONS

Type	Body Length (L, mm)	Body Diameter (D, mm)	Lead Wire Length (H, mm)	Lead Wire Diameter (d, mm)	Net Weight Per 1000Pcs
M204 M204T	3.2 ± 1.0	1.9 ± 0.2	28 ± 3.0	0.45 ± 0.02	145 Grams

GENERAL SPECIFICATIONS

Type	Power Rating At 70°C	Maximum Working Voltage	Maximum Overload Voltage	Minimum Resistance	Maximum Resistance	Resistance Tolerance	Available Resistance Values
M204	0.4W	200V	400V	1Ω	10MΩ	±1%, 5%	E-24/E-96
M204T	1/2W	250V	400V	1Ω	4.7MΩ	±1%, 5%	E-24/E-96

Special sizes, values, and specifications not listed available on special order.

POWER DERATING CURVE

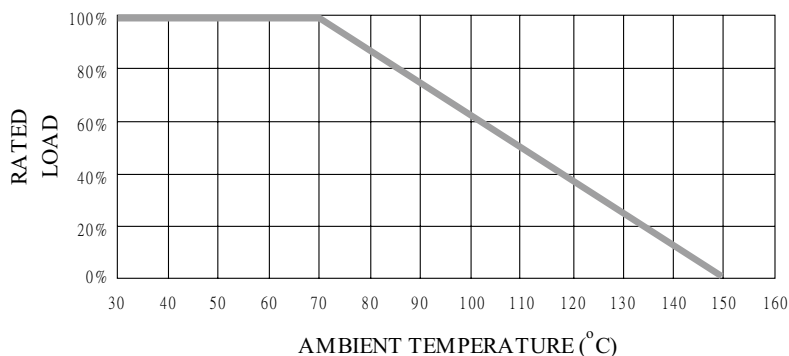

M-Series (T) MINIATURE SIZE Metal Film Fixed Power Resistor

Quality • Reliability
Cost-Down via Technology

■ PART NUMBER

Example: M204TF10K0TKSTB5K0

M204T	F	10K0	TKS	TB5K0
Type	Tolerance*	Resistance	TCR*	Packaging
	F (1%) J (5%)	10KΩ 4-character code containing - 3 significant digits 1 letter multiplier MULTIPLIER R = 1 K = 10 ³ M = 10 ⁶ G = 10 ⁹	100ppm 3-character code TKR = ± 50ppm TKS = ± 100ppm TKU = ± 250ppm	5-character code TB = Tape Box (pieces per box) <u>M204/M204T</u> 5K0 = 5,000

* Listed values may not be applicable across product types or to all resistance values. Please check with us before placing order.

■ TECHNICAL SUMMARY

Characteristics	Limits	
Dielectric Withstanding Voltage, V AC or DC	400	
Temperature Coefficient, PPM / °C*	M204	±50, ±100
	M204T	11Ω~1MΩ: ±100 1Ω~10Ω, 1M1~4M7Ω: ±250
Operating Temperature Range, °C	-55~+150	
Insulation Resistance, MΩ	M204	10 ⁵ Min.
	M204T	10 ⁴ Min.

* Not applicable to all resistance values. Please check with us regarding the PPM of specific resistance value(s).

■ PERFORMANCE SPECIFICATIONS

Characteristics	Test Conditions	Limits
Short Time Over Load	IEC 60115-1 4.13 2 seconds 2.5x rated voltage (not over max. overload voltage)	±1%
Load Life In Humidity	IEC 60115-1 4.24 56 days rated load at (40±2)°C and (93±3)% relative humidity	±2.5%
Load Life 1,000 hours	IEC 60115-1 4.25.1 Rated load with 1.5 hours ON, 0.5 hours OFF, at (70±2)°C	±2.5%
Resistance To Soldering Heat	IEC 60115-1 4.18 Leads immersed till 3mm from the body in (260±5)°C solder for 10±1 seconds	±1%
Solderability	IEC 60115-1 4.17.2 Solder area covered after (235±3)°C/(2±0.2) seconds with flux applied	95% Min.
Vibration	IEC 60115-1 4.22 Six hours in each parallel and axial direction with a simple harmonic motion having an amplitude of 0.75mm and 10 to 500 Hz.	±1%
Thermal Endurance	IEC 60115-1 4.25.3 1000 hours at 150°C without load	±1%
Thermal Shock	IEC 60115-1 4.19 -55°C 30minutes, +150°C 30minutes, 5 cycles	±1%

Quality • Reliability
Cost-Down via Technology

MM(P)

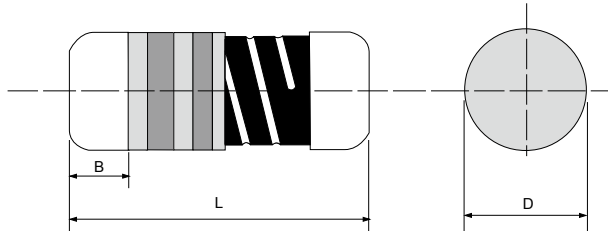

Specifications Per

- IEC 60115-1, IEC 60115-2
- EN 140401-803

Features

- SMD enabled structure
- Excellent solderability termination
- Products meet RoHS requirements and do not contain substances of very high concern identified by European Chemicals Agency

■ DIMENSIONS

Type	Body Length (L, mm)	Body Diameter (D, mm)	Soldering Spot (B, mm)	Net Weight Per 1000 pcs
MM16P	3.52 ± 0.08	1.35 ± 0.1	0.6 Min.	17 grams
MM204P	3.52 ± 0.08	1.35 ± 0.1	0.6 Min.	17 grams
MM207P	5.90 ± 0.20	2.20 ± 0.1	1.0 Min.	66 grams
MM52P	5.90 ± 0.20	2.20 ± 0.1	1.0 Min.	66 grams

■ GENERAL SPECIFICATIONS

Type	Power Rating At 70°C	Maximum Working Voltage	Maximum Overload Voltage	Minimum Resistance	Maximum Resistance	Resistance Tolerance	Available Resistance Values
MM16P	1/6W	200V	400V	0.1Ω	100KΩ	±1%	E-24/E-96
						±2%, ±5%	E-24
MM204P	1/4W	200V	400V	0.1Ω	100KΩ	±1%	E-24/E-96
						±2%, ±5%	E-24
MM207P	1/3W	300V	500V	0.1Ω	330KΩ	±1%	E-24/E-96
						±2%, ±5%	E-24
MM52P	1/2W	300V	500V	0.1Ω	330KΩ	±1%	E-24/E-96
						±2%, ±5%	E-24

For zero-ohm jumper, please see ZMM series. For 1m~510mΩ please see CSM series.
Special sizes and specifications available on request.

MM PULSE WITHSTANDING Metal Film MELF Resistor

Quality • Reliability
Cost-Down via Technology

POWER DERATING CURVE

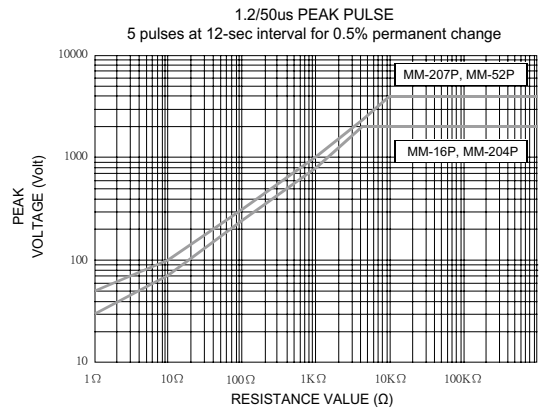
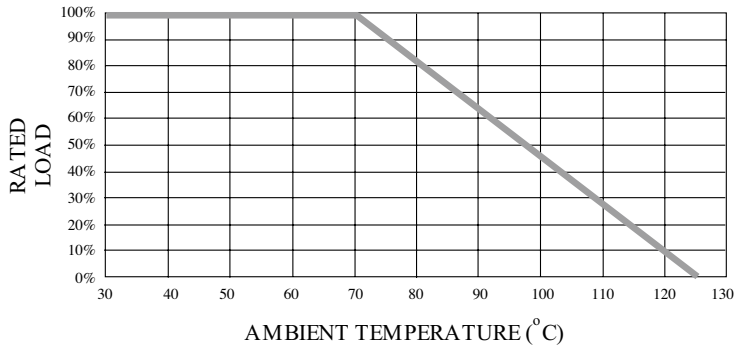

MM(P)

PART NUMBER

Example: MM52PJ10K0TKSTR2K0

MM52P	J	10K0	TKS	TR2K0
Type	Tolerance*	Resistance	TCR*	Packaging
	F (1%) G (2%) J (5%)	10KΩ 4-character code containing - 3 significant digits 1 letter multiplier <u>MULTIPLIER</u> R = 1 K = 10 ³ M = 10 ⁶ G = 10 ⁹	100ppm 3-character code TKR = ± 50ppm TKS = ± 100ppm	5-character code TR = Tape Reel (pieces per reel) <u>MM16P/MM204P</u> 3K0 = 3,000 6K0 = 6,000** 10K = 10,000** <u>MM207P/MM52P</u> 2K0 = 2,000 6K0 = 6,000** 10K = 10,000**

* Listed values may not be applicable across product types or to all resistance values. Please check with us before placing order.

** upon request

TECHNICAL SUMMARY

Characteristics	Limits			
Dielectric Withstanding Voltage, VAC or DC	MM16P, MM204P: 200 MM207P, MM52P: 500			
Temperature Coefficient, PPM / °C*	±1%, ±2%		±50	
	±5%		±100	
Operating Temperature Range, °C	-55 ~ +125			
Film Temperature, °C	MM16P	MM204P	MM207P	MM52P
	125	125	125	140
Insulation Resistance, MΩ	>10 ⁴			
Tin Whisker (JESD201 Temperature Cycling & High Temp. / Humidity Storage), μm	< 5			

* Not applicable to all resistance values. Please check with us regarding the PPM of specific resistance value(s).

PERFORMANCE SPECIFICATIONS

Characteristics	Test Conditions	Limits
Short Time Overload	IEC 60115-1 4.13 5 seconds 2.5x rated voltage (not over max. overload voltage)	±0.5%
Load Life In Humidity	IEC 60115-1 4.24 56 days rated load at (40±2)°C and (93±3)% relative humidity	±1.5%
Load Life 1,000 hours	IEC 60115-1 4.25.1 Rated load with 1.5 hours ON, 0.5 hours OFF, at (70±2)°C	±1.5%
Resistance To Soldering Heat	IEC 60115-1 4.18.2 Dip the resistor into a solder bath measured (260±5)°C and hold it for a 10±1 seconds	±0.5%
Solderability	IEC 60115-1 4.17.2 Solder area covered after (235±3)°C/(2±0.2) seconds with flux applied	95% Min.
Vibration	IEC 60115-1 4.22 Six hours in each parallel and axial direction with a simple harmonic motion having an amplitude of 1.52mm and 10 to 2,000 Hz.	±1%
Thermal Endurance	IEC 60115-1 4.25.3 1000 hours at 125°C without load	±0.5%
Thermal Shock	IEC 60115-1 4.19 -55°C 30minutes, +125°C 30minutes, 5 cycles	±0.5%

SRM-201 withstands 51,840,000 surges at 30KV, in duration of 500 hours.



Firstohm®

第一電

Surge Resistor Pulse Resistor
High Voltage Resistor Surge MELF
Power MELF High Temperature Resistor
Dual Power Resistor Spark Gap Resistor
All General-Purpose Resistors

Phone: +886-2-27051878, 27051879, 27079869

Fax: +886-2-27036701

E-mail: QR@Firstohm.com.tw

<http://www.Firstohm.com.tw>

TÜV ISO 9002 ISO 14001 / IECQ CERTIFIED FACTORY

MM Metal Film MELF Resistor

Quality • Reliability
Cost-Down via Technology

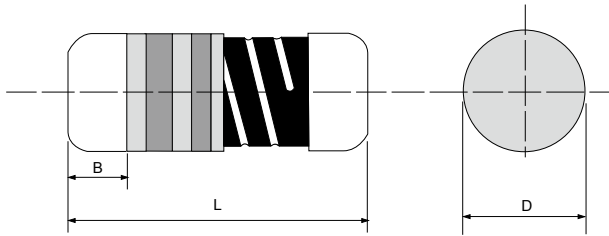

Specifications Per

- IEC 60115-1, IEC 60115-2
- EN140401-803

Features

- SMD enabled structure
- Excellent solderability termination
- Products meet RoHS requirements and do not contain substances of very high concern identified by European Chemicals Agency

DIMENSIONS

Type	Body Length (L, mm)	Body Diameter (D, mm)	Soldering Spot (B, mm)	Net Weight Per 1000 pcs
MM16	3.52 ± 0.08	1.35 ± 0.1	0.6 Min.	17 grams
MM204	3.52 ± 0.08	1.35 ± 0.1	0.6 Min.	17 grams
MM207	5.90 ± 0.20	2.20 ± 0.1	1.0 Min.	66 grams
MM52	5.90 ± 0.20	2.20 ± 0.1	1.0 Min.	66 grams

GENERAL SPECIFICATIONS

Type	Power Rating At 70°C	Maximum Working Voltage	Maximum Overload Voltage	Minimum Resistance	Maximum Resistance	Resistance Tolerance	Available Resistance Values
MM16	1/6W	200V	400V	0.51Ω	10MΩ	±1%	E-24/E-96
						±2%, ±5%	E-24
MM204	1/4W	200V	400V	0.51Ω	10MΩ	±1%	E-24/E-96
						±2%, ±5%	E-24
MM207	1/3W	300V	500V	0.51Ω	10MΩ	±1%	E-24/E-96
						±2%, ±5%	E-24
MM52	1/2W	300V	500V	0.51Ω	10MΩ	±1%	E-24/E-96
						±2%, ±5%	E-24

For zero-ohm jumper, please see ZMM series. For 1m~510mΩ please see CSM series.
Special sizes and specifications available on request.

PART NUMBER

Example: MM204F162RTKRTR3K0

MM204	F	162R	TKR	TR3K0
Type	Tolerance*	Resistance	TCR*	Packaging
	F (1%) G (2%) J (5%)	162Ω 4-character code containing - 3 significant digits 1 letter multiplier MULTIPLIER R = 1 K = 10 ³ M = 10 ⁶ G = 10 ⁹	50ppm 3-character code TKQ = ± 25ppm TKR = ± 50ppm TKS = ± 100ppm	5-character code TR = Tape Reel (pieces per reel) MM16/MM204 3K0 = 3,000 6K0 = 6,000** 10K = 10,000** MM207/MM52 2K0 = 2,000 6K0 = 6,000** 10K = 10,000**

* Listed values may not be applicable across product types or to all resistance values. Please check with us before placing order. **upon request

TECHNICAL SUMMARY

Characteristics	Ranges & Limits	
Operating Temperature Range, °C	-55 ~ +125	
Temperature Coefficient, PPM / °C*	±1%, ±2%	±25, ±50, ±100
	±5%	±100
Dielectric Withstanding Voltage, VAC or DC	MM16, MM204	200
	MM207, MM52	500
Insulation Resistance, MΩ	>10 ⁴	
Film Temperature, °C	MM16, MM204, MM207	125
	MM52	140
Power Derating, Linear	100% for temp. < 70 °C down to zero at 125°C	
Tin Whisker (JESD201 Temperature Cycling & High Temp. / Humidity Storage), μm	<5	

* Not applicable to all resistance values. Please check with us regarding the PPM of specific resistance value(s).

SINGLE SURGE PERFORMANCE

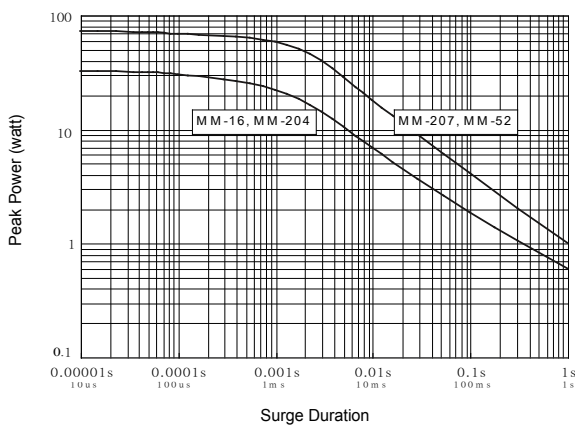

SURGE POWER DERATING CURVE

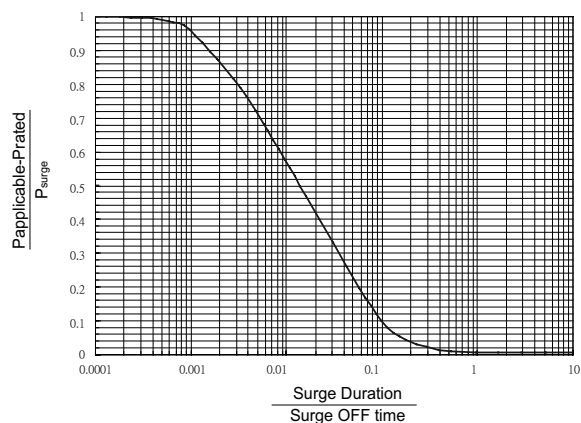

Notes:

• SINGLE SURGE PERFORMANCE graph is good for NON REPETITIVE applications operating in an ambient temperature of 70°C or less. For temperatures above 70°C, the graph power must be derated further linearly down to zero at 125°C.

• To determine applicable surge power in continuous-surge applications:

1. Identify allowable duration and peak power P_{surge} of single surge;
2. Determine ratio of surge duration/surge OFF time in application;
3. Calculate P_{applicable} backwardly according to Y-axis of SURGE POWER DERATING CURVE.

■ PERFORMANCE SPECIFICATIONS

Characteristics	Test Conditions	Limits	
Short Time Overload	IEC 60115-1 4.13 5 seconds 2.5x rated voltage (not over max. overload voltage)	0.51Ω to 332KΩ	±0.25%
		>332KΩ	±0.5%
Load Life	IEC 60115-1 4.25.1 Rated load 1,000 hours with 1.5 hours ON, 0.5 hours OFF, at (70±2)°C	0.51Ω to 332KΩ	±0.5%
		>332KΩ	±1.0%
Load Life In Humidity	IEC 60115-1 4.24 56 days rated load at (40±2)°C and (93±3)% relative humidity	±1.0%	
Load Life In Humidity (accelerated mode)	IEC 60115-1 4.37 1,000 hours at 85°C and 85% relative humidity with 0.1x rated voltage (not over 100V)	0.51Ω to <100KΩ	±1.0%
		100KΩ to 332KΩ	±2.0%
		>332KΩ	±5.0%
Periodic Electric Overload	IEC 60115-1 4.39 3.9x rated voltage (not over max. overload voltage) with 0.1s ON, 2.5s OFF for 1,000 cycles	±1.0%	
Resistance To Soldering Heat	IEC 60115-1 4.18.2 Dip the resistor into a solder bath measured (260±5)°C and hold it for a 10±1 seconds	±0.5%	
Thermal Endurance	IEC 60115-1 4.25.3 1,000 hours without load	85°C	±0.25%
		125°C	±0.5%
Thermal Shock	IEC 60115-1 4.19 -55°C 30minutes, +125°C 30minutes	5 cycles	±0.5%
		1,000 cycles	±1.5%
Single pulse high voltage overload	IEC 60115-1 4.27 <ul style="list-style-type: none"> • 5 pulses of 1.2/50μs at 10x rated voltage (not over 400V for MM16 & MM204; not over 500V for MM207 & MM52) with interval of 12 sec. • 10 pulses of 10/700μs at 10x rated voltage (not over 400V for MM16 & MM204; not over 500V for MM207 & MM52) with interval of 60 sec. 	±0.5	
		±0.5	
Electrostatic discharge (Human body model)	IEC 60115-1 4.38 3 positive & 3 negative discharges with 2KV for MM16 & MM204 or 4KV for MM207 & MM52 (For continuous surge application please see Surge Performance paragraph)	±2.0	
Climatic test	IEC 60115-1 4.23 4.23.2 - dry heat: 16 hours 125°C 4.23.3 - damp heat: 24 hours 55°C with 95% relative humidity 4.23.4 - cold: 2 hours -55°C 4.23.5 - negative air pressure: 2 hour 8.5KPa at (25±10)°C 4.23.6 - damp heat cyclic: 5 days 55°C with 95% relative humidity 4.23.7 - DC load: rated voltage at -55°C and 125°C each 1 Min.	±1.0	
Solderability	IEC 60115-1 4.17.2 Solder area covered after (235±3)°C/(2±0.2) seconds with flux applied	> 95%	
Vibration	IEC 60115-1 4.22 Six hours in each parallel and axial direction with a simple harmonic motion having an amplitude of 1.52mm and 10 to 2,000 Hz.	±1.0%	
Bending test	IEC 60115-1 4.33 Pressing depth 2mm, 3 times	±0.25%	
Flammability	IEC 60115-1 4.35 Needle flame test 10s	No burning after 30s	

Quality • Reliability
Cost-Down via Technology

■ SUGGESTED PAD LAYOUT

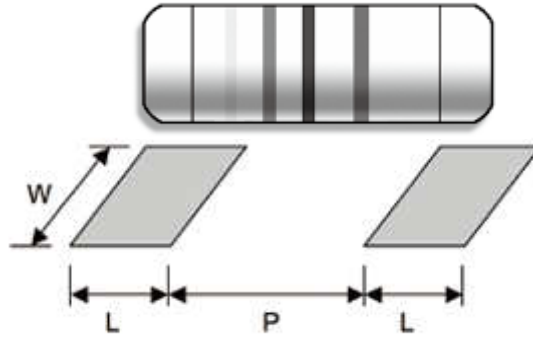

Type	Soldering Mode	Pad Length (L, mm, Min.)	Pad Spacing (P, mm)	Pad Width (W, mm, Min.)
MM16 MM204	Reflow	1.0	2.0 ± 0.2	1.6
	Wave	1.2	2.0 ± 0.2	1.6
MM207 MM52	Reflow	2.0	3.0 ± 0.3	3.0
	Wave	2.5	3.0 ± 0.3	3.0

For better heat dissipation / lower heat resistance, increase W & L.

■ COVER TAPE PEELING SPECIFICATION

Recommended peeling force: 50±5gf

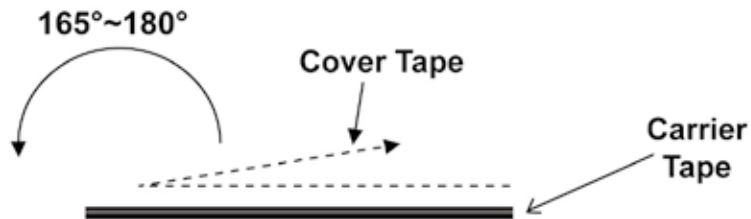

MMP - Metal Film MELF Precision Resistor

Quality • Reliability
Cost-Down via Technology

MMP

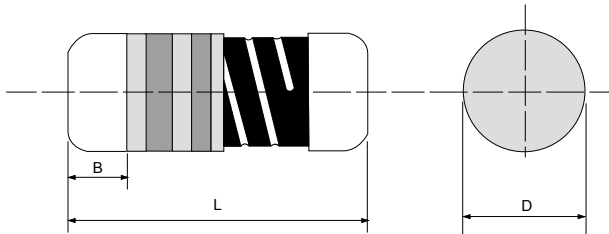

Specifications Per

- IEC 60115-1, IEC 60115-2
- EN140401-803

Features

- SMD enabled structure
- Excellent solderability termination
- Products meet RoHS requirements and do not contain substances of very high concern identified by European Chemicals Agency

DIMENSIONS

Type	Body Length (L, mm)	Body Diameter (D, mm)	Soldering Spot (B, mm)	Net Weight Per 1000 pcs
MMP16	3.52 ± 0.08	1.35 ± 0.1	0.6 Min.	17 grams
MMP204	3.52 ± 0.08	1.35 ± 0.1	0.6 Min.	17 grams
MMP207	5.90 ± 0.20	2.20 ± 0.1	1.0 Min.	66 grams
MMP52	5.90 ± 0.20	2.20 ± 0.1	1.0 Min.	66 grams

GENERAL SPECIFICATIONS

Type	Power Rating (at 70°C)	Maximum Working Voltage (AC/DC)	Maximum Overload Voltage (AC/DC)	Minimum Resistance	Maximum Resistance	Resistance Tolerance	Available Resistance Values
MMP16	1/6W	200V	400V	10Ω	1MΩ	± 0.5%	E-24/E192
				22Ω	510KΩ	± 0.25%	
				43Ω	510KΩ	± 0.1%	
MMP204	1/4W	200V	400V	10Ω	1MΩ	± 0.5%	E-24/E192
				22Ω	510KΩ	± 0.25%	
				43Ω	510KΩ	± 0.1%	
MMP207	1/3W	300V	500V	10Ω	1MΩ	± 0.5%	E-24/E192
				15Ω	1MΩ	± 0.25%	
				33Ω	1MΩ	± 0.1%	
MMP52	1/2W	300V	500V	10Ω	1MΩ	± 0.5%	E-24/E192
				15Ω	1MΩ	± 0.25%	
				33Ω	1MΩ	± 0.1%	

For zero-ohm jumper, please see ZMM series. For 500mohm & under, please see CSM series. Special sizes, values, and specifications not listed available on special order.

TECHNICAL SUMMARY

Characteristics	Ranges & Limits	
Operating Temperature Range, °C	-55 ~ +125	
Temperature Coefficient, PPM / °C*	±5, ±10, ±15, ±25, ±50 (See below for availability)	
Dielectric Withstanding Voltage, VAC or DC	MMP16, MMP204	MMP207, MMP52
	300	500
Insulation Resistance, MΩ	>10 ⁴	
Film Temperature	MMP16, MMP204	MMP207, MMP52
	125°C	125°C
Power Derating, Linear	100% for < 70°C, down to zero at 125°C	
Failure Rate, pcs/10 ⁹ device hours	MMP16, MMP207	MMP204, MMP52
	<1	<1.5
Tin Whisker (JESD201 Temperature Cycling & High Temp./Humidity Storage), μm	<5	

* Not applicable to all resistance values. Please check with us regarding the PPM of specific resistance value(s).

TEMPERATURE COEFFICIENT AVAILABILITY

Specifications		Resistance Values Available			
TC	Tolerance	MMP16	MMP204	MMP207	MMP52
±5 PPM / °C	±0.5%	100Ω~10KΩ		75Ω~15KΩ	
	±0.25%				
	±0.1%				
±10, ±15 PPM / °C	±0.5%	10Ω~510KΩ	10Ω~330KΩ	10Ω~750KΩ	10Ω~680KΩ
	±0.25%	22Ω~510KΩ	22Ω~330KΩ	15Ω~680KΩ	15Ω~510KΩ
	±0.1%	43Ω~510KΩ	43Ω~330KΩ	33Ω~680KΩ	33Ω~510KΩ
±25 PPM / °C	±0.5%	10Ω~750KΩ		10Ω~1MΩ	10Ω~750KΩ
	±0.25%	22Ω~510KΩ		15Ω~1MΩ	15Ω~680KΩ
	±0.1%	43Ω~510KΩ		33Ω~1MΩ	33Ω~680KΩ
±50 PPM / °C	±0.5%	10Ω~1MΩ		10Ω~1MΩ	
	±0.25%	22Ω~510KΩ		15Ω~1MΩ	
	±0.1%	43Ω~510KΩ		33Ω~1MΩ	

MMP - Metal Film MELF Precision Resistor

Quality • Reliability
Cost-Down via Technology

MMP

■ SINGLE SURGE PERFORMANCE

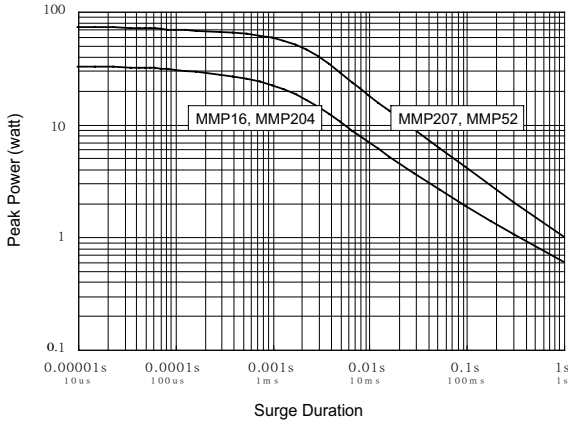

■ SURGE POWER DERATING CURVE

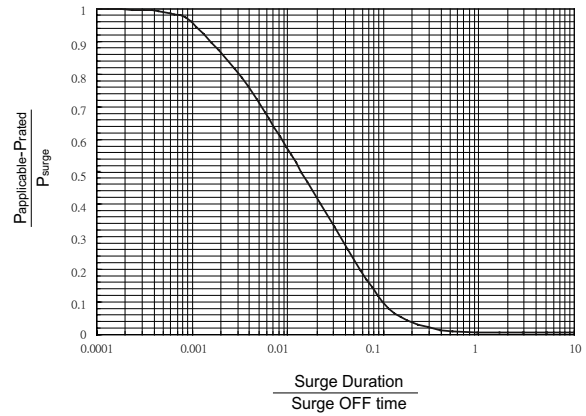

Notes:

• SINGLE SURGE PERFORMANCE graph is good for NON REPETITIVE applications operating in an ambient temperature of 70°C or less. For temperatures above 70°C, the graph power must be derated further linearly down to zero at 125°C.

- To determine applicable surge power in continuous-surge applications:
 1. Identify allowable duration and peak power P_{surge} of single surge;
 2. Determine ratio of surge duration/surge OFF time in application;
 3. Calculate $P_{applicable}$ backwardly according to Y-axis of SURGE POWER DERATING CURVE.

■ PART NUMBER

Example: MMP52B2K61TKQTR2K0

MMP52	B	2K61	TKQ	TR2K0
Type	Tolerance*	Resistance	TCR*	Packaging
	B (0.1%) C (0.25%) D (0.5%)	2.61KΩ 4-character code containing - 3 significant digits 1 letter multiplier <u>MULTIPLIER</u> R = 1 K = 10 ³ M = 10 ⁶ G = 10 ⁹	25ppm 3-character code TKM = ± 5 ppm TKN = ± 10 ppm TKP = ± 15 ppm TKQ = ± 25 ppm TKR = ± 50 ppm	5-character code TR = Tape Reel (pieces per reel) <u>MMP16/MMP204</u> 3K0 = 3,000 6K0 = 6,000** 10K = 10,000** <u>MMP207/MMP52</u> 2K0 = 2,000 6K0 = 6,000** 10K = 10,000**

* Listed values may not be applicable across product types or to all resistance values. Please check with us before placing order.

** upon request

■ PERFORMANCE SPECIFICATIONS

Characteristics	Test Conditions	Limits	
Short Time Overload	IEC 60115-1 4.13 5 seconds 2.5x rated voltage (not over max. overload voltage)	± 0.25%	
Load Life	IEC 60115-1 4.25.1 Rated load 1,000 hrs with 1.5 hours ON, 0.5 hours OFF, at (70±2)°C	10Ω to <10KΩ	±0.2%
		10KΩ to 332KΩ	±0.25%
		>332KΩ	±0.5%
Load Life In Humidity	IEC 60115-1 4.24 56 days rated load at (40±2)°C and (93±3)% relative humidity	± 1.0%	
Load Life In Humidity (accelerated mode)	IEC 60115-1 4.37 1,000 hours at 85°C and 85% relative humidity with 0.1x rated voltage (not over 100V)	10Ω to <10KΩ	±1.0%
		10KΩ to 332KΩ	±1.5%
		>332KΩ	±3.0%
Periodic Electric Overload	IEC 60115-1 4.39 3.9x rated voltage (not over max. overload voltage) with 0.1s ON, 2.5s OFF for 1,000 cycles	± 0.5%	
Resistance To Soldering Heat	IEC 60115-1 4.18.2 Dip the resistor into a solder bath measured (260±5)°C and hold it for a 10±1 seconds	± 0.5%	
Thermal Endurance	IEC 60115-1 4.25.3 1,000 hours without load	85°C	± 0.25%
		125°C	± 0.5%
Thermal Shock	IEC 60115-1 4.19 -55°C 30minutes, +125°C 30minutes	5 cycles	± 0.25%
		1,000 cycles	± 1.5%
Single pulse high voltage overload	IEC 60115-1 4.27 Severity no.4 10 pulses of 10/700µs at 10x rated voltage (not over max. overload voltage) with interval of 60 sec.	± 0.5%	
Electrostatic discharge (Human body model)	IEC 60115-1 4.38 3 positive & 3 negative discharges with 2KV for MMP16 & MMP204 or 4KV for MMP207 & MMP52 (For continuous surge application please see Surge Performance paragraph)	± 1.0%	
Climatic test	IEC 60115-1 4.23 4.23.2 - dry heat: 16 hours 125°C 4.23.3 - damp heat: 24 hours 55°C with 95% relative humidity 4.23.4 - cold: 2 hours -55°C 4.23.5 - negative air pressure: 2 hour 8.5kPa at (25±10)°C 4.23.6 - damp heat cyclic: 5 days 55°C with 95% relative humidity 4.23.7 - DC load: rated voltage at -55°C and 125°C each 1 Min.	± 1.0%	
Solderability	IEC 60115-1 4.17.2 Solder area covered after (235±3)°C/(2±0.2) seconds with flux applied	> 95%	
Vibration	IEC 60115-1 4.22 Six hours in each parallel and axial direction with a simple harmonic motion having an amplitude of 1.52mm and 10 to 2,000 Hz.	± 1.0%	
Bending test	IEC 60115-1 4.33 Pressing depth 2mm, 3 times	± 0.25%	
Flammability	IEC 60115-1 4.35 Needle flame test 10s	No burning after 30s	

Quality • Reliability
Cost-Down via Technology

MMP

■ SUGGESTED PAD LAYOUT

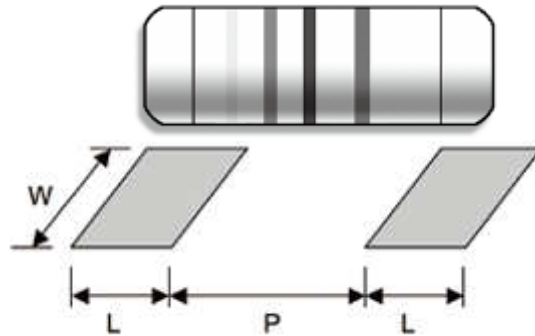

Type	Soldering Mode	Pad Length (L, mm, Min.)	Pad Spacing (P, mm)	Pad Width (W, mm, Min.)
MMP16	Reflow	1.0	2.0 ± 0.2	1.6
MMP204	Wave	1.2	2.0 ± 0.2	1.6
MMP207	Reflow	2.0	3.0 ± 0.3	3.0
MMP52	Wave	2.5	3.0 ± 0.3	3.0

For better heat dissipation / lower heat resistance, increase W & L.

■ COVER TAPE PEELING SPECIFICATION

Recommended peeling force: 50±5gf

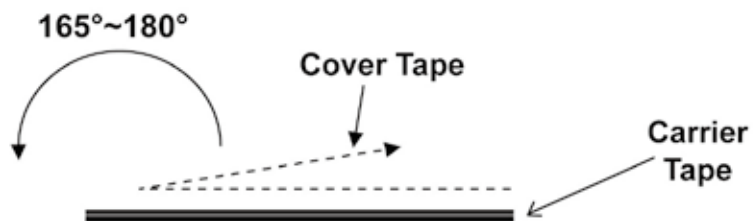

Firstohm®



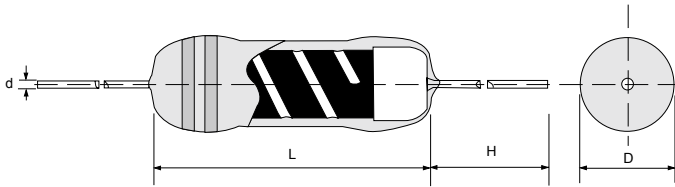

Specifications Per

- IEC 60115-4
- MIL-11804

Features

- Flameproof multi-layer coating meets UL 94 V-0
- Flameproof feature meets overload test UL 1412
- Solvent resistant
- Special tin-plated electrolytic copper lead wire
- Products meet RoHS requirements and do not contain substances of very high concern identified by European Chemicals Agency

■ DIMENSIONS

Type	Body Length (L, mm)	Body Diameter (D, mm)	Lead Wire Length (H, mm)	Lead Wire Diameter (d, mm)	Net Weight Per 1000Pcs
MO50	8.80 ± 1.0	3.2 ± 0.2	28 ± 3.0	0.6 ± 0.03	340 Grams
MO100	11.0 ± 1.0	4.0 ± 0.5	28 ± 3.0	0.7 ± 0.03	500 Grams
MO200	13.5 ± 1.0	5.0 ± 0.5	30 ± 3.0	0.8 ± 0.03	1050 Grams
MO300	15.5 ± 1.0	5.5 ± 0.5	30 ± 3.0	0.8 ± 0.03	1200 Grams
MO400	19.0 ± 1.0	6.0 ± 0.5	30 ± 3.0	0.8 ± 0.03	1620 Grams
MO500	19.0 ± 1.0	8.0 ± 0.5	30 ± 3.0	0.8 ± 0.03	3100 Grams
MO600	24.0 ± 1.0	8.0 ± 0.5	30 ± 3.0	0.8 ± 0.03	3700 Grams
MO700	31.5 ± 1.0	8.0 ± 0.5	30 ± 3.0	0.8 ± 0.03	4000 Grams
MO1000	52.5 ± 1.5	8.0 ± 0.5	39 ± 3.0	0.8 ± 0.03	6900 Grams

■ GENERAL SPECIFICATIONS

Type	Power Rating (at 70°C)	Maximum Working Voltage	Maximum Overload Voltage	Minimum Resistance	Maximum Resistance	Resistance Tolerance	Available Resistance Values
MO050	1/2W	350V	600V	0.1Ω	120KΩ	±5%	E-24
MO100	1W	350V	600V	0.1Ω	120KΩ	±5%	E-24
MO200	2W	350V	700V	0.1Ω	150KΩ	±5%	E-24
MO300	3W	350V	700V	0.1Ω	150KΩ	±5%	E-24
MO400	4W	450V	800V	0.1Ω	180KΩ	±5%	E-24
MO500	5W	500V	1000V	0.1Ω	200KΩ	±5%	E-24
MO600	6W	500V	1000V	0.1Ω	220KΩ	±5%	E-24
MO700	7W	600V	1200V	0.22Ω	220KΩ	±5%	E-24
MO1000	10W	1000V	2000V	0.33Ω	330KΩ	±5%	E-24

Special sizes, values, and specifications not listed available on special order.

Quality • Reliability
Cost-Down via Technology

TAPING SPECIFICATIONS

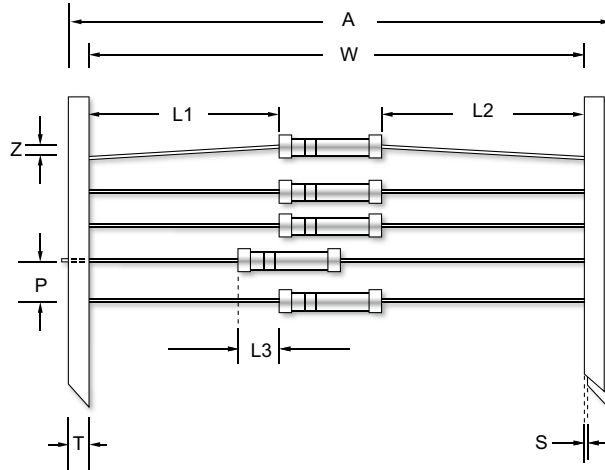

Unit (mm)

Type	A (Max.)	L1-L2 (Max.)	L3 (Max.)	P ±0.5	S (Max.)	T ±0.5	W ±1.5	Z (Max.)
MO50	65	±1.0	0.5	5.0	0.8	6.0	52.5	1.2
MO100	65	±1.0	0.5	5.0	0.8	6.0	52.5	1.2
MO200	76	±1.5	1.0	10.0	0.8	6.0	63.5	1.2
MO300	76	±1.5	1.0	10.0	0.8	6.0	63.5	1.2
MO400	76	±1.5	1.0	10.0	0.8	6.0	63.5	1.2
MO500	76	±1.5	1.0	10.0	0.8	6.0	63.5	1.2
MO600	97	±1.5	1.0	10.0	0.8	6.0	83.0	1.2
MO700	97	±1.5	1.0	10.0	0.8	6.0	83.0	1.2
MO1000	Available only in bulk package.							

POWER DERATING CURVE

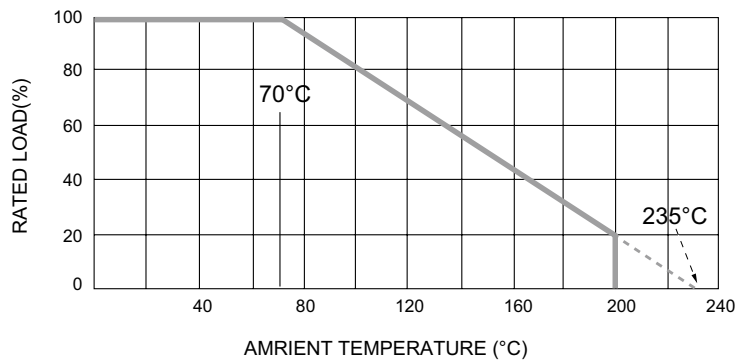

Quality • Reliability
Cost-Down via Technology

MO

TECHNICAL SUMMARY

Characteristics	Limits
Dielectric Withstanding Voltage, VAC or DC	MO050: 350 MO100 / MO200: 600 MO300 to MO1000: 1000
Temperature Coefficient, PPM / °C*	Typically ±300
Operating Temperature Range, °C	-55~+200
Insulation Resistance, MΩ	10 ⁴

* Not applicable to all resistance values. Please check with us regarding the PPM of specific resistance value(s).

PART NUMBER

Example: MO200J10K0TKZTB500

MO200	J	10K0	TKZ	TB500
Type	Tolerance	Resistance	TCR	Packaging
	J (5%)	10KΩ 4-character code containing - 3 significant digits 1 letter multiplier <u>MULTIPLIER</u> R = 1 K = 10 ³ M = 10 ⁶ G = 10 ⁹	3-character code TKZ = Default Product Temperature Coefficient. Information of typical product temperature coefficient can be found in the Technical Summary section of the datasheet.*	5-character code TB = Tape Box (pieces per box) <u>MO50</u> 2K0 = 2,000 <u>MO100</u> 1K0 = 1,000 <u>MO200/300/400</u> 500 = 500 <u>MO500</u> 400 = 400 <u>MO600/700</u> 250 = 250 (Bulk Packaging Only) <u>MO1000</u> BK250

* For the availabilities of non-default temperature coefficient, please check with us. Reference for TCR letter codes can be found in section (4) of Part Number Construction in the Appendices.

■ PERFORMANCE SPECIFICATIONS

Characteristics	Test Conditions	Limits
Short Time Over Load	IEC 60115-1 4.13 5 seconds 2.5x rated voltage (not over max. overload voltage)	±1%
Load Life In Humidity	IEC 60115-1 4.24 56 days rated load at (40±2)°C and (93±3)% relative humidity	±5%
Load Life 1,000 hours	IEC 60115-1 4.25.1 Rated load with 1.5 hours ON, 0.5 hours OFF, at (70±2)°C	±5%
Resistance To Soldering Heat	IEC 60115-1 4.18.2 Leads immersed till 3mm from the body in (260±5)°C solder for 10±1 seconds	±1%
Solderability	IEC 60115-1 4.17.2 Solder area covered after (235±3)°C/(2±0.2) seconds with flux applied	90% Min.
Vibration	IEC 60115-1 4.22 Six hours in each parallel and axial direction with a simple harmonic motion having an amplitude of 1.52mm and 10 to 2,000 Hz.	±1%
Thermal Endurance	IEC 60115-1 4.25.3 1000 hours at 200°C without load	±1%
Thermal Shock	IEC 60115-1 4.19 -55°C 30minutes, +150°C 30minutes, 5 cycles	±2%

Quality • Reliability
Cost-Down via Technology

MO

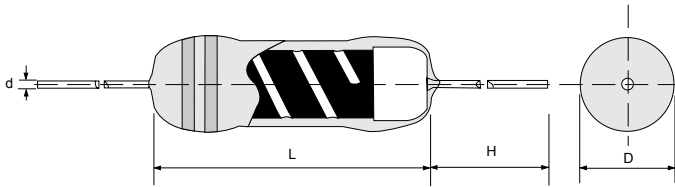

Specifications Per

- IEC 60115-4
- MIL-11804

Features

- Flameproof multi-layer coating meets UL 94 V-0
- Flameproof feature meets overload test UL 1412
- Solvent resistant
- Special tin-plated electrolytic copper lead wire
- Products meet RoHS requirements and do not contain substances of very high concern identified by European Chemicals Agency

■ DIMENSIONS

Type	Body Length (L, mm)	Body Diameter (D, mm)	Lead Wire Length (H, mm)	Lead Wire Diameter (d, mm)	Net Weight Per 1000Pcs
MO51	6.50 ± 1.0	2.6 ± 0.2	26 ± 3.0	0.6 ± 0.03	300 Grams
MO101	8.80 ± 1.0	3.2 ± 0.5	28 ± 3.0	0.6 ± 0.03	340 Grams
MO201	11.0 ± 1.0	4.0 ± 0.5	28 ± 3.0	0.7 ± 0.03	500 Grams
MO301	13.5 ± 1.0	5.0 ± 0.5	30 ± 3.0	0.8 ± 0.03	1050 Grams
MO401	15.5 ± 1.0	5.5 ± 0.5	30 ± 3.0	0.8 ± 0.03	1200 Grams
MO501	19.0 ± 1.0	6.0 ± 0.5	30 ± 3.0	0.8 ± 0.03	1620 Grams
MO601	19.0 ± 1.0	8.0 ± 0.5	30 ± 3.0	0.8 ± 0.03	3100 Grams

■ GENERAL SPECIFICATIONS

Type	Power Rating (at 70°C)	Maximum Working Voltage	Maximum Overload Voltage	Minimum Resistance	Maximum Resistance	Resistance Tolerance	Available Resistance Values
MO51	1/2W	250V	500V	0.1Ω	100KΩ	±5%	E-24
MO101	1W	300V	600V	0.1Ω	120KΩ	±5%	E-24
MO201	2W	350V	600V	0.1Ω	120KΩ	±5%	E-24
MO301	3W	350V	700V	0.1Ω	150KΩ	±5%	E-24
MO401	4W	350V	700V	0.1Ω	150KΩ	±5%	E-24
MO501	5W	450V	800V	0.1Ω	180KΩ	±5%	E-24
MO601	6W	500V	800V	0.1Ω	200KΩ	±5%	E-24

Special sizes, values, and specifications not listed available on special order.

Quality • Reliability
Cost-Down via Technology

■ PART NUMBER

Example: MO301J10K0TKZTB500

MO301	J	10K0	TKZ	TB500
Type	Tolerance	Resistance	TCR	Packaging
	J (5%)	10KΩ 4-character code containing - 3 significant digits 1 letter multiplier MULTIPLIER R = 1 K = 10 ³ M = 10 ⁶ G = 10 ⁹	3-character code TKZ = Default Product Temperature Coefficient. Information of typical product temperature coefficient can be found in the Technical Summary section of the datasheet.*	5-character code TB = Tape Box (pieces per box) <u>MO51/MO101</u> 2K0 = 2,000 <u>MO201</u> 1K0 = 1,000 <u>MO301/401/501</u> 500 = 500 <u>MO601</u> 400 = 400

* For the availabilities of non-default temperature coefficient, please check with us.
Reference for TCR letter codes can be found in section (4) of Part Number Construction in the Appendices.

■ TECHNICAL SUMMARY

Characteristics	Limits	
Dielectric Withstanding Voltage, VAC or DC	1/2W	250V
	1W	300V
	2W to 4W	350V
	5W	450V
	6W	500V
Temperature Coefficient, PPM/°C*	Typically ±300	
Operating Temperature Range, °C	-55~+200	
Insulation Resistance, MΩ	10 ⁴	

* Not applicable to all resistance values. Please check with us regarding the PPM of specific resistance value(s).

Quality • Reliability
Cost-Down via Technology

MO

TAPING SPECIFICATIONS

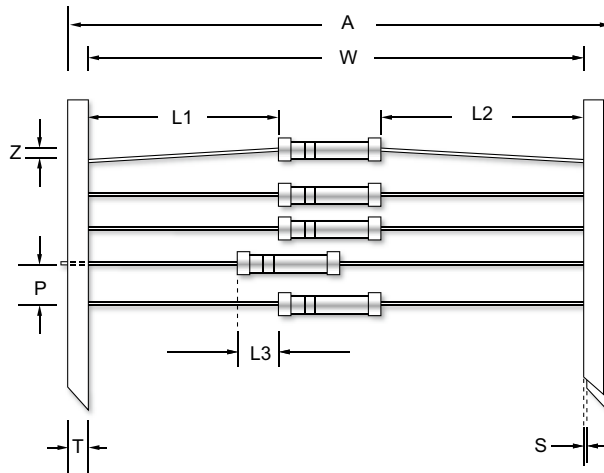

Unit (mm)

Type	A (Max.)	L1-L2 (Max.)	L3 (Max.)	P ±0.5	S (Max.)	T ±0.5	W ±1.5	Z (Max.)
MO51	65	±1.0	0.5	5.0	0.8	6.0	52.5	1.2
MO101	65	±1.0	0.5	5.0	0.8	6.0	52.5	1.2
MO201	65	±1.0	0.5	5.0	0.8	6.0	52.5	1.2
MO301	76	±1.5	1.0	10.0	0.8	6.0	63.5	1.2
MO401	76	±1.5	1.0	10.0	0.8	6.0	63.5	1.2
MO501	76	±1.5	1.0	10.0	0.8	6.0	63.5	1.2
MO601	76	±1.5	1.0	10.0	0.8	6.0	63.5	1.2

POWER DERATING CURVE

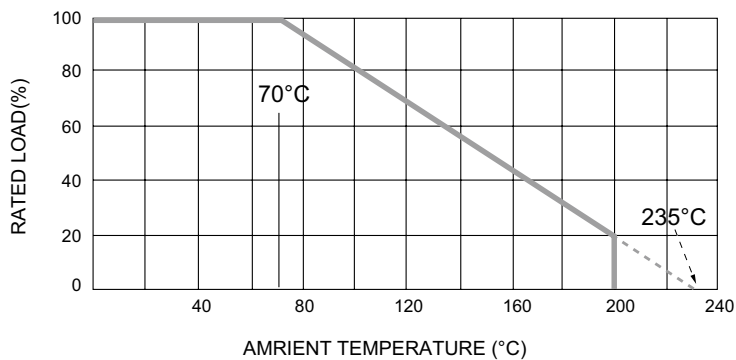

■ PERFORMANCE SPECIFICATIONS

Characteristics	Test Conditions	Limits
Short Time Over Load	IEC 60115-1 4.13 5 seconds 2.5x rated voltage (not over max. overload voltage)	±1%
Load Life In Humidity	IEC 60115-1 4.24 56 days rated load at (40±2)°C and (93±3)% relative humidity	±5%
Load Life 1,000 hours	IEC 60115-1 4.25.1 Rated load with 1.5 hours ON, 0.5 hours OFF, at (70±2)°C	±5%
Resistance To Soldering Heat	IEC 60115-1 4.18.2 Leads immersed till 3mm from the body in (260±5)°C solder for 10±1 seconds	±1%
Solderability	MIL-STD-202 Method 208 Solder area covered after (235±3)°C/(2±0.2) seconds with flux applied	90% Min.
Vibration	MIL-STD-202 Method 204 Six hours in each parallel and axial direction with a simple harmonic motion having an amplitude of 1.52mm and 10 to 2,000 Hz.	±1%
Thermal Endurance	IEC 60115-1 4.25.3 1000 hours at 200°C without load	±1%
Thermal Shock	IEC 60115-1 4.19 -55°C 30minutes, +150°C 30minutes, 5 cycles	±1%

Quality • Reliability
Cost-Down via Technology

MP

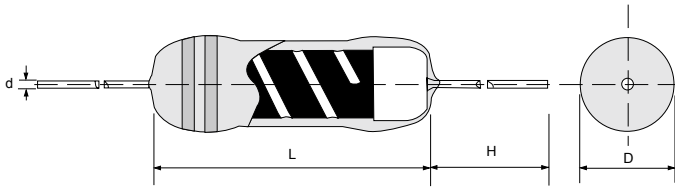

Specifications Per

- IEC 60115-1
- MIL R-10509

Features

- Conformal multi-layer coating
- Color code per MIL & EIA standards
- Special tin-plated electrolytic copper lead wire
- Products meet RoHS requirements and do not contain substances of very high concern identified by European Chemicals Agency

DIMENSIONS

Type	Body Length (L, mm)	Body Diameter (D, mm)	Lead Wire Length (H, mm)	Lead Wire Diameter (d, mm)	Net Weight Per 1000Pcs
MP16	3.2 ± 1.0	1.9 ± 0.2	28 ± 3.0	0.45 ± 0.02	145 Grams
MP25	6.5 ± 1.0	2.4 ± 0.2	26 ± 3.0	0.55 ± 0.03	220 Grams
MP51	8.8 ± 1.0	3.2 ± 0.2	26 ± 3.0	0.60 ± 0.03	340 Grams

GENERAL SPECIFICATIONS

Type	Power Rating (at 70°C)	Maximum Working Voltage	Maximum Overload Voltage	Minimum Resistance	Maximum Resistance	Resistance Tolerance	Available Resistance Values
MP16	1/6W	150V	300V	10Ω	500KΩ	±0.5%	E-24/E-192
						±0.25%	
						±0.1%	
						±0.05%	
MP25	1/4W	250V	500V	10Ω	1MΩ	±0.5%	E-24/E-192
						±0.25%	
						±0.1%	
						±0.05%	
MP51	1/2W	350V	700V	10Ω	1MΩ	±0.5%	E-24/E-192
						±0.25%	
						±0.1%	
						±0.05%	

Special sizes, values, and specifications not listed available on special order.

Quality • Reliability
Cost-Down via Technology

■ TAPING SPECIFICATIONS

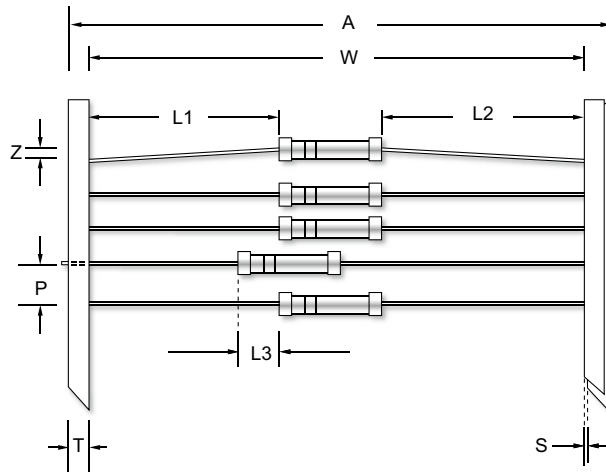

Unit (mm)

Type	A (Max.)	L1-L2 (Max.)	L3 (Max.)	P ±0.5	S (Max.)	T ±0.5	W ±1.5	Z (Max.)
MP16	65	±1.0	0.5	5.0	0.8	6.0	52.5	1.2
MP25	65	±1.0	0.5	5.0	0.8	6.0	52.5	1.2
MP51	65	±1.0	0.5	5.0	0.8	6.0	52.5	1.2

Type	Packing Type	MP16	MP25	MP51
Minimum Packing QTY (pcs)	Ammo pack	5000	5000	2000

MP

Quality • Reliability
Cost-Down via Technology

MP

POWER DERATING CURVE

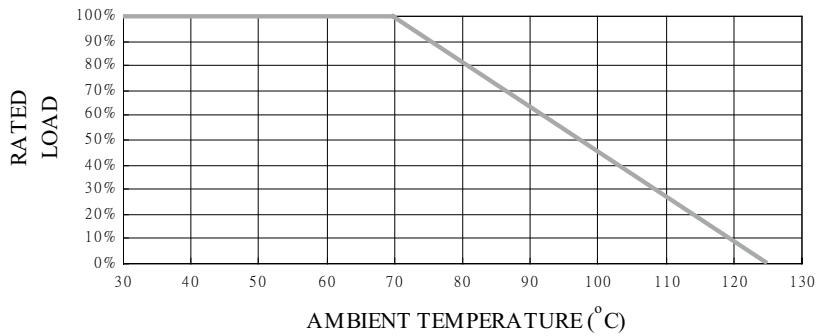

PART NUMBER

Example: MP25B49K9TKQTB5K0

MP25	B	49K9	TKQ	TB5K0
Type	Tolerance*	Resistance	TCR*	Packaging
	B (0.1%) C (0.25%) D (0.5%)	49.9KΩ 4-character code containing - 3 significant digits 1 letter multiplier MULTIPLIER R = 1 K = 10 ³ M = 10 ⁶ G = 10 ⁹	25ppm 3-character code TKN = ± 10 ppm TKP = ± 15 ppm TKQ = ± 25 ppm TKR = ± 50 ppm	5-character code TB = Tape Box (pieces per box) <u>MP16/MP25</u> 5K0 = 5,000 <u>MP51</u> 2K0 = 2,000

* Listed values may not be applicable across product types or to all resistance values. Please check with us before placing order.

TECHNICAL SPECIFICATIONS

Characteristics	Limits	
Dielectric Withstanding Voltage, VAC or DC	MP16 MP25 MP51	300 500 700
Temperature Coefficient, PPM / °C*	±50, ±25, ±15, ±10	
Operating Temperature Range, °C	-55~+125	
Insulation Resistance, MΩ	10 ⁴	

* Not applicable to all resistance values. Please check with us regarding the PPM of specific resistance value(s).

■ PERFORMANCE SPECIFICATIONS

Characteristics	Test Conditions	Limits
Short Time Over Load	IEC 60115-1 4.13 5 seconds 2.5x rated voltage (not over max. overload voltage)	±0.15%
Load Life In Humidity	IEC 60115-1 4.24 56 days rated load at (40±2)°C and (93±3)% relative humidity	±0.75%
Load Life 1,000 hours	IEC 60115-1 4.25.1 Rated load with 1.5 hours ON, 0.5 hours OFF, at (70±2)°C	±0.5%
Resistance To Soldering Heat	IEC 60115-1 4.18.2 Leads immersed till 3mm from the body in (260±5)°C solder for 10±1 seconds	±0.15%
Solderability	IEC 60115-1 4.17.2 Solder area covered after (235±3)°C/(2±0.2) seconds with flux applied	95% Min.
Vibration	IEC 60115-1 4.22 Six hours in each parallel and axial direction with a simple harmonic motion having an amplitude of 0.75mm and 10 to 500 Hz.	±0.1%
Thermal Endurance	IEC 60115-1 4.25.3 1000 hours at 125°C without load	±0.15%
Thermal Shock	IEC 60115-1 4.19 -55°C 30minutes, +125°C 30minutes, 5 cycles	±0.15%

MSD MINIATURE SIZE Pulse Safety Resistor

Quality • Reliability
Cost-Down via Technology

MSD

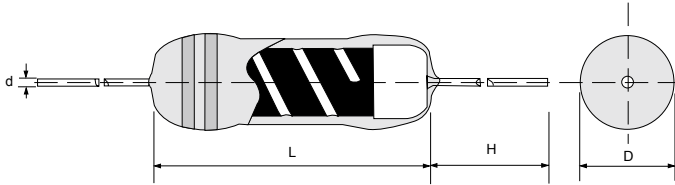

Specifications Per

- IEC 60115-4
- MIL-11804

Features

- Special composite film on high grade ceramic substrate
- Flameproof coating meets UL 94 V-0 and overload test UL 1412
- Excellent anti-surge capability
- Absorbs pulse from city power line, direct crossing or inductive coupling
- Protects electric equipment or parts from accidental shock
- Low-cost alternative to wire-wound resistors
- Products meet RoHS requirements and do not contain substances of very high concern identified by European Chemicals Agency

■ DIMENSIONS

Type	Body Length (L, mm)	Body Diameter (D, mm)	Lead Wire Length (H, mm)	Lead Wire Diameter (d, mm)	Net Weight Per 1000 Pcs
MSD51	6.50 ± 0.5	2.6 ± 0.2	28 ± 3.0	0.6 ± 0.03	300 Grams
MSD101	8.80 ± 1.0	3.2 ± 0.3	28 ± 3.0	0.6 ± 0.03	340 Grams
MSD201	11.0 ± 1.0	4.0 ± 0.5	28 ± 3.0	0.7 ± 0.03	500 Grams
MSD301	13.5 ± 1.0	5.0 ± 0.5	30 ± 3.0	0.8 ± 0.03	1050 Grams
MSD401	15.5 ± 1.0	5.5 ± 0.5	30 ± 3.0	0.8 ± 0.03	1200 Grams
MSD501	19.0 ± 1.0	6.0 ± 0.5	30 ± 3.0	0.8 ± 0.03	1620 Grams
MSD601	19.0 ± 1.0	8.0 ± 0.5	30 ± 3.0	0.8 ± 0.03	3100 Grams

■ GENERAL SPECIFICATIONS

Type	Power Rating (at 70°C)	Maximum Working Voltage	Maximum Overload Voltage	Minimum Resistance	Maximum Resistance	Resistance Tolerance	Available Resistance Values
MSD51	1/2W	350V	600V	0.1Ω	120KΩ	±0.1~5%	E-24/E-96
MSD101	1W	350V	600V	0.1Ω	120KΩ	±0.1~5%	E-24/E-96
MSD201	2W	350V	600V	0.1Ω	120KΩ	±0.1~5%	E-24/E-96
MSD301	3W	350V	700V	0.1Ω	150KΩ	±0.1~5%	E-24/E-96
MSD401	4W	350V	700V	0.1Ω	150KΩ	±0.1~5%	E-24/E-96
MSD501	5W	450V	800V	0.1Ω	180KΩ	±0.1~5%	E-24/E-96
MSD601	6W	500V	800V	0.1Ω	200KΩ	±0.1~5%	E-24/E-96

Special sizes, values, and specifications not listed available on special order.

Quality • Reliability
Cost-Down via Technology

■ TAPING SPECIFICATIONS

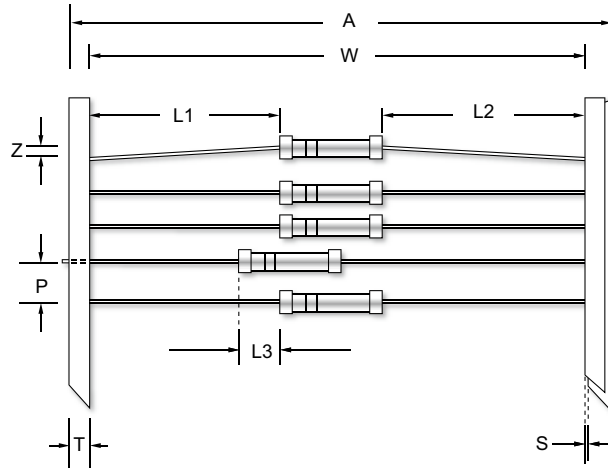

Unit (mm)

Type	A (Max.)	L1-L2 (Max.)	L3 (Max.)	P ±0.5	S (Max.)	T ±0.5	W ±1.5	Z (Max.)
MSD51	65	±1.0	0.5	5.0	0.8	6.0	52.5	1.2
MSD101	65	±1.0	0.5	5.0	0.8	6.0	52.5	1.2
MSD201	76	±1.5	1.0	10.0	0.8	6.0	63.5	1.2
MSD301	76	±1.5	1.0	10.0	0.8	6.0	63.5	1.2
MSD401	76	±1.5	1.0	10.0	0.8	6.0	63.5	1.2
MSD501	76	±1.5	1.0	10.0	0.8	6.0	63.5	1.2
MSD601	76	±1.5	1.0	10.0	0.8	6.0	63.5	1.2

■ POWER DERATING CURVE

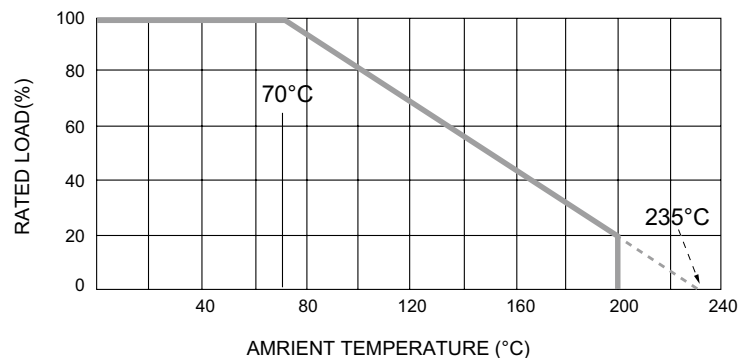

MSD

Quality • Reliability
Cost-Down via Technology

■ SINGLE SURGE PERFORMANCE

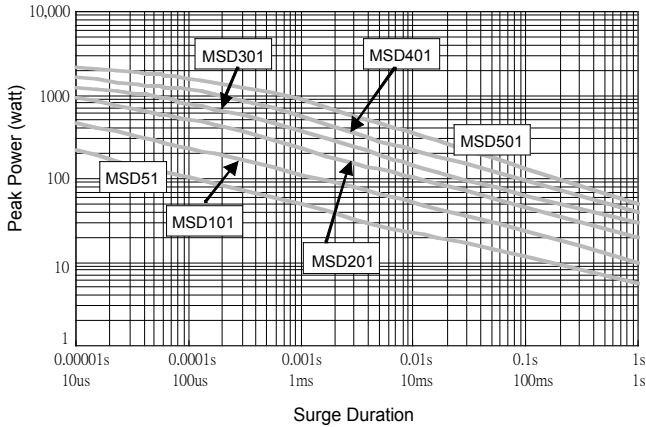

■ SURGE POWER DERATING CURVE

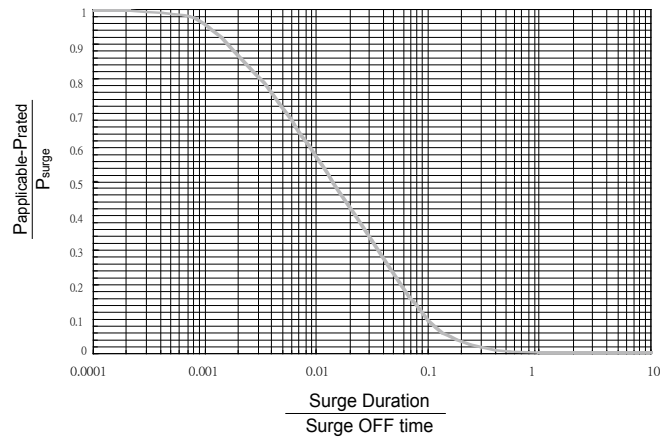

Notes:

- Above graph is accurate for NON REPETITIVE applications operating in an ambient temperature of 70°C or less. For temperatures above 70°C, the graph power must be derated further by 0.62% per °C until 200°C.
- For applicable surge power in continuous-surge applications please see SURGE POWER DERATING CURVE.

■ TECHNICAL SPECIFICATIONS

Characteristics	Limits	
Dielectric Withstanding Voltage, VAC or DC	1/2W	350
	1W to 2W	600
	3W to 6W	1000
Temperature Coefficient, PPM / °C*	±20~±300 (Typically ±300)	
Operating Temperature Range, °C	-55~+200	
Insulation Resistance, MΩ	10 ⁴	

* Not applicable to all resistance values. Please check with us regarding the PPM of specific resistance value(s).

■ SURGE PERFORMANCE SPECIFICATIONS

Characteristics		Limits
Max. Surge Voltage	MSD51	3000V DC
	MSD101	4000V DC
	MSD201	5000V DC
	MSD301	5500V DC
	MSD401	6000V DC
	MSD501	6500V DC
	MSD601	7000V DC
Surge Voltage = $\sqrt{(1000 \times P \times R)}$ DC P is power rating, R is resistance value, surge voltage is not more than 2 times of max. surge voltage. Surge spec = 1.2/50µs Period = 1 sec Number of surges = 50		±5%

MSD MINIATURE SIZE Pulse Safety Resistor

Quality • Reliability
Cost-Down via Technology

■ PART NUMBER

Example: MSD301J10K0TKZTB500

MSD301	J	10K0	TKZ	TB500
Type	Tolerance*	Resistance	TCR	Packaging
	B (0.1%) D (0.5%) F (1%) J (5%)	10KΩ 4-character code containing - 3 significant digits 1 letter multiplier MULTIPLIER R = 1 K = 10 ³ M = 10 ⁶ G = 10 ⁹	3-character code TKZ = Default Product Temperature Coefficient. Information of typical product temperature coefficient can be found in the Technical Summary section of the datasheet.**	5-character code TB = Tape Box (pieces per box) <u>MSD51/MSD101</u> 2K0 = 2,000 <u>MSD201</u> 1K0 = 1,000 <u>MSD301/401/501</u> 500 = 500 <u>MSD601</u> 400 = 400

* Listed values may not be applicable to all product types or to all resistance values. Please check with us before placing order.

** For the availabilities of non-default temperature coefficient, please check with us. Reference for TCR letter codes can be found in section (4) of Part Number Construction in the Appendices.

■ PERFORMANCE SPECIFICATIONS

Characteristics	Test Conditions	Limits
Short Time Over Load	IEC 60115-1 4.13 5 seconds 2.5x rated voltage (not over max. overload voltage)	±1%
Load Life In Humidity	IEC 60115-1 4.24 56 days rated load at (40±2)°C and (93±3)% relative humidity	±5%
Load Life 1,000 hours	IEC 60115-1 4.25.1 Rated load with 1.5 hours ON, 0.5 hours OFF, at (70±2)°C	±5%
Resistance To Soldering Heat	IEC 60115-1 4.18.2 Leads immersed till 3mm from the body in (260±5)°C solder for 10±1 seconds	±1%
Solderability	IEC 60115-1 4.17.2 Solder area covered after (235±3)°C/(2±0.2) seconds with flux applied	90% Min.
Vibration	IEC 60115-1 4.22 Six hours in each parallel and axial direction with a simple harmonic motion having an amplitude of 1.52mm and 10 to 2,000 Hz.	±1%
Thermal Endurance	IEC 60115-1 4.25.3 1000 hours at 200°C without load	±1%
Thermal Shock	IEC 60115-1 4.19 -55°C 30minutes, +155°C 30minutes, 5 cycles	±1%

MSD

MSD Pulse Safety Resistor

Quality • Reliability
Cost-Down via Technology

MSD

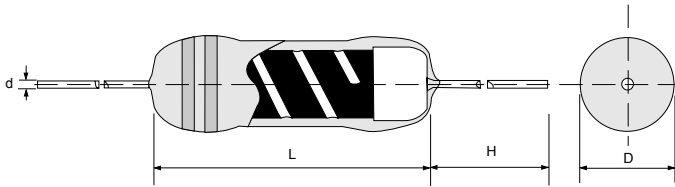

Specifications Per

- IEC 60115-4
- MIL-11804

Features

- Special composite film on high grade ceramic substrate
- Flameproof coating meets UL 94 V-0 and overload test UL 1412
- Excellent anti-surge capability
- Absorbs pulse from city power line, direct crossing or inductive coupling
- Protects electric equipment or parts from accidental shock
- Low-cost alternative to wire-wound resistors
- Products meet RoHS requirements and do not contain substances of very high concern identified by European Chemicals Agency

DIMENSIONS

Type	Body Length (L, mm)	Body Diameter (D, mm)	Lead Wire Length (H, mm)	Lead Wire Diameter (d, mm)	Net Weight Per 1000 Pcs
MSD25	6.50 ± 1.0	2.6 ± 0.2	26 ± 3.0	0.6 ± 0.03	300 Grams
MSD50	8.80 ± 1.0	3.2 ± 0.3	28 ± 3.0	0.6 ± 0.03	340 Grams
MSD100	11.0 ± 1.0	4.0 ± 0.5	28 ± 3.0	0.7 ± 0.03	500 Grams
MSD200	13.5 ± 1.0	5.0 ± 0.5	30 ± 3.0	0.8 ± 0.03	1050 Grams
MSD300	15.5 ± 1.0	5.5 ± 0.5	30 ± 3.0	0.8 ± 0.03	1200 Grams
MSD400	19.0 ± 1.0	6.0 ± 0.5	30 ± 3.0	0.8 ± 0.03	1600 Grams
MSD500	19.0 ± 1.0	8.0 ± 0.5	30 ± 3.0	0.8 ± 0.03	3100 Grams
MSD600	24.0 ± 1.0	8.0 ± 0.5	30 ± 3.0	0.8 ± 0.03	3700 Grams

GENERAL SPECIFICATIONS

Type	Power Rating (at 70°C)	Maximum Working Voltage	Maximum Overload Voltage	Minimum Resistance	Maximum Resistance	Resistance Tolerance	Available Resistance Values
MSD25	1/4W	250V	500V	0.1Ω	1MΩ	±5%	E-24
MSD50	1/2W	350V	500V	0.1Ω	120KΩ	±0.1~5%	E-24/E-96
MSD100	1W	350V	600V	0.1Ω	120KΩ	±0.1~5%	E-24/E-96
MSD200	2W	350V	600V	0.1Ω	150KΩ	±0.1~5%	E-24/E-96
MSD300	3W	350V	700V	0.1Ω	150KΩ	±0.1~5%	E-24/E-96
MSD400	4W	450V	700V	0.1Ω	180KΩ	±0.1~5%	E-24/E-96
MSD500	5W	500V	800V	0.1Ω	200KΩ	±0.1~5%	E-24/E-96
MSD600	6W	500V	1000V	0.1Ω	220KΩ	±0.1~5%	E-24/E-96

Special sizes, values, and specifications not listed available on special order.

Quality • Reliability
Cost-Down via Technology

MSD

■ TAPING SPECIFICATIONS

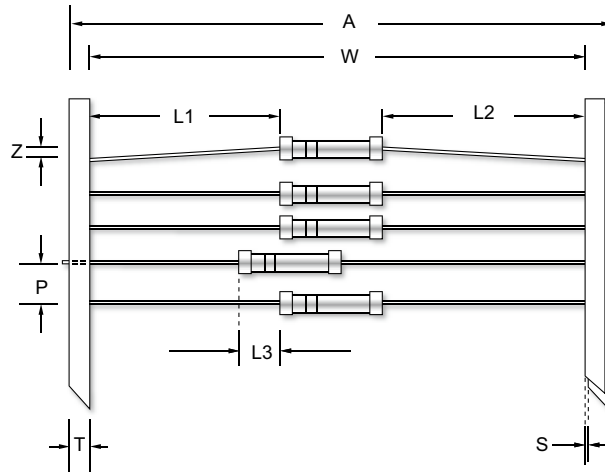

Unit (mm)

Type	A (Max.)	L1-L2 (Max.)	L3 (Max.)	P ±0.5	S (Max.)	T ±0.5	W ±1.5	Z (Max.)
MSD25	65	±1.0	0.5	5.0	0.8	6.0	52.5	1.2
MSD50	65	±1.0	0.5	5.0	0.8	6.0	52.5	1.2
MSD100	65	±1.0	0.5	5.0	0.8	6.0	52.5	1.2
MSD200	76	±1.5	1.0	10.0	0.8	6.0	63.5	1.2
MSD300	76	±1.5	1.0	10.0	0.8	6.0	63.5	1.2
MSD400	76	±1.5	1.0	10.0	0.8	6.0	63.5	1.2
MSD500	76	±1.5	1.0	10.0	0.8	6.0	63.5	1.2
MSD600	97	±1.5	1.0	10.0	0.8	6.0	83.0	1.2

■ POWER DERATING CURVE

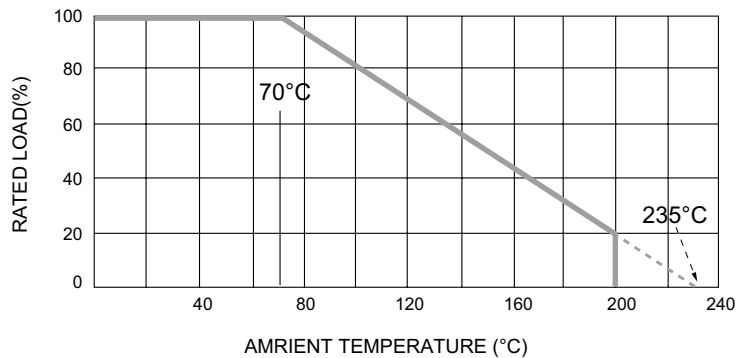

MSD Pulse Safety Resistor

Quality • Reliability
Cost-Down via Technology

■ SINGLE SURGE PERFORMANCE

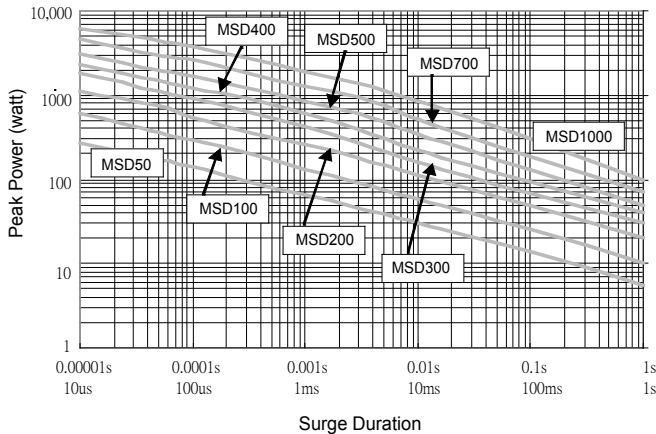

■ SURGE POWER DERATING CURVE

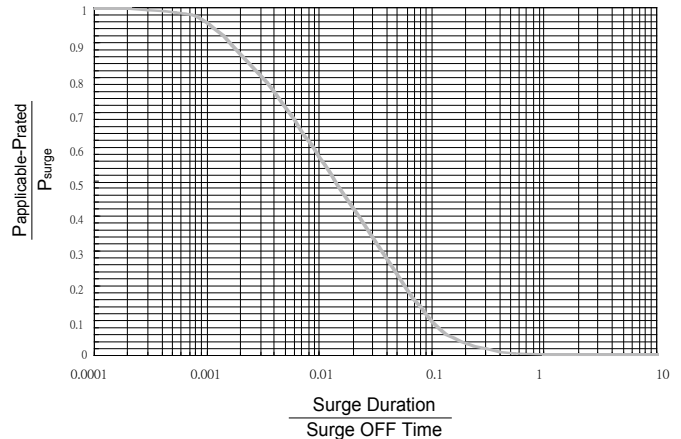

Notes:

- Above graph is accurate for NON REPETITIVE applications operating in an ambient temperature of 70°C or less. For temperatures above 70°C, the graph power must be derated further by 0.62% per °C until 200°C.
- For applicable surge power in continuous-surge applications please see SURGE POWER DERATING CURVE.

■ TECHNICAL SPECIFICATIONS

Characteristics	Limits	
Dielectric Withstanding Voltage, VAC or DC	1/4W	250
	1/2W	350
	1W to 2W	600
	3W to 6W	1000
Temperature Coefficient, PPM / °C*	±20~±300 (Typically ±300)	
Operating Temperature Range, °C	-55~+200	
Insulation Resistance, MΩ	10 ⁴	

* Not applicable to all resistance values. Please check with us regarding the PPM of specific resistance value(s).

■ SURGE PERFORMANCE SPECIFICATIONS

Characteristics		Limits
Max. Surge Voltage	MSD50	4000V DC
	MSD100	5000V DC
	MSD200	6000V DC
	MSD300	7000V DC
	MSD400	7500V DC
	MSD500	8000V DC
	MSD600	9000V DC
	MSD1000	10000V DC
Surge Voltage = $\sqrt{(1200 \times P \times R)}$ DC P is power rating, R is resistance value, surge voltage is not more than 2 times of max. surge voltage. Surge spec = 1.2/50µs Period = 1 sec Number of surges = 50		±5%

MSD Pulse Safety Resistor

Quality • Reliability
Cost-Down via Technology

■ PART NUMBER

Example: MSD200J10K0TKZTB500

MSD200	J	10K0	TKZ	TB500
Type	Tolerance*	Resistance	TCR	Packaging
	B (0.1%) D (0.5%) F (1%) J (5%)	10KΩ 4-character code containing - 3 significant digits 1 letter multiplier <u>MULTIPLIER</u> R = 1 K = 10 ³ M = 10 ⁶ G = 10 ⁹	3-character code TKZ = Default Product Temperature Coefficient. Information of typical product temperature coefficient can be found in the Technical Summary section of the datasheet.**	5-character code TB = Tape Box (pieces per box) <u>MSD25/MSD50</u> 2K0 = 2,000 <u>MSD100</u> 1K0 = 1,000 <u>MSD200/300/400</u> 500 = 500 <u>MSD500</u> 400 = 400 <u>MSD600</u> 250 = 250

* Listed values may not be applicable to all product types or to all resistance values. Please check with us before placing order.

** For the availabilities of non-default temperature coefficient, please check with us. Reference for TCR letter codes can be found in section (4) of Part Number Construction in the Appendices.

■ PERFORMANCE SPECIFICATIONS

Characteristics	Test Conditions	Limits
Short Time Over Load	IEC 60115-1 4.13 5 seconds 2.5x rated voltage (not over max. overload voltage)	±1%
Load Life In Humidity	IEC 60115-1 4.24 56 days rated load at (40±2)°C and (93±3)% relative humidity	±5%
Load Life 1,000 hours	IEC 60115-1 4.25.1 Rated load with 1.5 hours ON, 0.5 hours OFF, at (70±2)°C	±5%
Resistance To Soldering Heat	IEC 60115-1 4.18.2 Leads immersed till 3mm from the body in (260±5)°C solder for 10±1 seconds	±1%
Solderability	IEC 60115-1 4.17.2 Solder area covered after (235±3)°C/(2±0.2) seconds with flux applied	90% Min.
Vibration	IEC 60115-1 4.22 Six hours in each parallel and axial direction with a simple harmonic motion having an amplitude of 1.52mm and 10 to 2,000 Hz.	±1%
Thermal Endurance	IEC 60115-1 4.25.3 1000 hours at 200°C without load	±1%
Thermal Shock	IEC 60115-1 4.19 -55°C 30minutes, +155°C 30minutes, 5 cycles	1/4W 1/2~6W ±2% ±3%

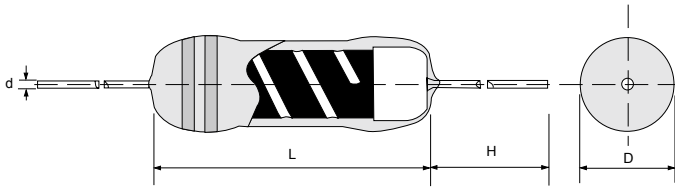

Specifications Per

- IEC 60115-1
- MIL-R-10509

Features

- Higher working voltage with improved reliability
- Proprietary conductive film
- Especially suitable for SMPS & lighting devices
- Low-cost alternative to metal-glazed resistors
- Products meet RoHS requirements and do not contain substances of very high concern identified by European Chemicals Agency

DIMENSIONS

Type	Body Length (L, mm)	Body Diameter (D, mm)	Lead Wire Length (H, mm)	Lead Wire Diameter (d, mm)	Net Weight Per 1000Pcs
MVR20	3.20 ± 1.0	1.9 ± 0.2	28 ± 3.0	0.45 ± 0.03	145 Grams
MVR25	6.50 ± 1.0	2.4 ± 0.2	26 ± 3.0	0.55 ± 0.03	220 Grams
MVR51	8.80 ± 1.0	3.2 ± 0.2	26 ± 3.0	0.60 ± 0.03	340 Grams
MVR100	11.0 ± 1.0	4.5 ± 0.5	26 ± 3.0	0.70 ± 0.03	600 Grams
MVR200	15.5 ± 1.0	5.5 ± 0.5	26 ± 3.0	0.80 ± 0.03	1200 Grams

GENERAL SPECIFICATIONS

Type	Power Rating (at 70°C)	Maximum Working Voltage	Maximum Overload Voltage	Minimum Resistance	Maximum Resistance	Resistance Tolerance	Available Resistance Values
MVR20	1/4W	550V DC 400V RMS	1.1KV DC 800V RMS	47KΩ	33MΩ	±0.1%~ 5%	E-24/E-96
MVR25	1/4W	1.1KV DC 800V RMS	2.2KV DC 1.6KV RMS	47KΩ	33MΩ	±0.1%~ 5%	E-24/E-96
MVR51	1/2W	2.3KV DC 1.6KV RMS	4.6KV DC 3.2KV RMS	47KΩ	68MΩ	±0.1%~ 5%	E-24/E-96
MVR100	1W	4KV DC 2.8KV RMS	8KV DC 5.6KV RMS	47KΩ	100MΩ	±0.1%~ 5%	E-24/E-96
MVR200	2W	7KV DC 5KV RMS	14KV DC 10KV RMS	47KΩ	100MΩ	±0.1%~ 5%	E-24/E-96

Special sizes, values, and specifications not listed available on special order.

Quality • Reliability
Cost-Down via Technology

■ POWER DERATING CURVE

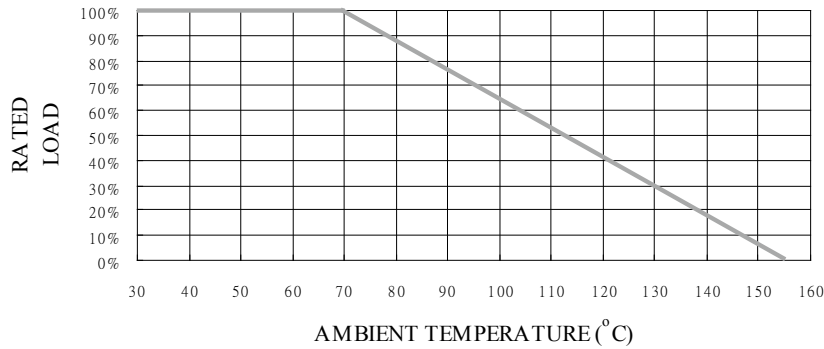

MVR

■ PART NUMBER

Example: MVR100J470KTKZTB1K0

MVR100	J	470K	TKZ	TB1K0
Type	Tolerance*	Resistance	TCR	Packaging
	B (0.1%) C (0.25%) D (0.5%) F (1%) J (5%)	470KΩ 4-character code containing - 3 significant digits 1 letter multiplier <u>MULTIPLIER</u> R = 1 K = 10 ³ M = 10 ⁶ G = 10 ⁹	3-character code TKZ = Default Product Temperature Coefficient. Information of typical product temperature coefficient can be found in the Technical Summary section of the datasheet.**	5-character code TB = Tape Box (pieces per box) <u>MVR20/MVR25</u> 5K0 = 5,000 <u>MVR51</u> 2K0 = 2,000 <u>MVR100</u> 1K0 = 1,000 <u>MVR200</u> 500 = 500

* Listed values may not be applicable to all product types or to all resistance values. Please check with us before placing order.

** For the availabilities of non-default temperature coefficient, please check with us. Reference for TCR letter codes can be found in section (4) of Part Number Construction in the Appendices.

TECHNICAL SPECIFICATIONS

Characteristics	Limits
Dielectric Withstanding Voltage, VAC or DC	MVR20: 300 MVR25: 500 MVR51: 700 MVR100/MVR200: 1000
Temperature Coefficient, PPM / °C*	±100, ±200, ±400, ±800
Operating Temperature Range, °C	-55 ~ +155
Insulation Resistance, MΩ	>10 ⁴

* Not applicable to all resistance values. Please check with us regarding the PPM of specific resistance value(s).

PERFORMANCE SPECIFICATIONS

Characteristics	Test Conditions	Limits
Short Time Over Load	IEC 60115-1 4.13 5 seconds 2.5x rated voltage (not over max. overload voltage)	±1%
Load Life In Humidity	IEC 60115-1 4.24 56 days rated load at (40±2)°C and (93±3)% relative humidity	±1%
Load Life 1,000 hours	IEC 60115-1 4.25.1 Rated load with 1.5 hours ON, 0.5 hours OFF, at (70±2)°C	±1.5%
Resistance To Soldering Heat	IEC 60115-1 4.18.2 Leads immersed till 3mm from the body in (260±5)°C solder for 10±1 seconds	±1%
Solderability	IEC 60115-1 4.17.2 Solder area covered after (235±3)°C/(2±0.2) seconds with flux applied	95% Min.
Vibration	IEC 60115-1 4.22 Six hours in each parallel and axial direction with a simple harmonic motion having an amplitude of 0.75mm and 10 to 500 Hz.	±1%
Thermal Endurance	IEC 60115-1 4.25.3 1000 hours at 155°C without load	±1%
Thermal Shock	IEC 60115-1 4.19 -55°C 30minutes, +155°C 30minutes, 5 cycles	±2%

Firstohm®



NFR - Non Flammable Carbon Film Resistor

Quality • Reliability
Cost-Down via Technology

NFR

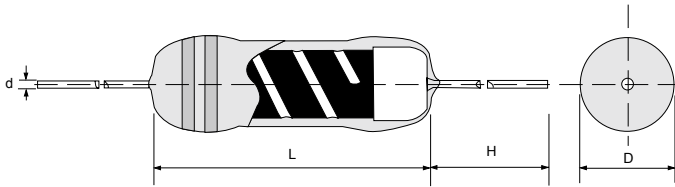

Specifications Per

- IEC 60115-1, IEC 60115-4
- MIL-R-10509

Features

- Conformal multi-layer non-flammable coating
- Color code per MIL & EIA standards
- Special tin-plated electrolytic copper lead wire
- Products meet RoHS requirements and do not contain substances of very high concern identified by European Chemicals Agency

DIMENSIONS

Type	Body Length (L, mm)	Body Diameter (D, mm)	Lead Wire Length (H, mm)	Lead Wire Diameter (d, mm)	Net Weight Per 1000Pcs
NFR16	3.20 ± 1.0	1.9 ± 0.2	28 ± 3.0	0.45 ± 0.02	145 Grams
NFR20	3.20 ± 1.0	1.9 ± 0.2	28 ± 3.0	0.45 ± 0.02	145 Grams
NFR25	6.50 ± 1.0	2.4 ± 0.2	26 ± 3.0	0.55 ± 0.03	220 Grams
NFR51	8.80 ± 1.0	3.2 ± 0.2	26 ± 3.0	0.60 ± 0.03	340 Grams
NFR52	6.50 ± 1.0	2.6 ± 0.3	26 ± 3.0	0.55 ± 0.03	300 Grams
NFR100	11.0 ± 1.0	4.5 ± 0.5	26 ± 3.0	0.70 ± 0.03	600 Grams
NFR200	15.5 ± 1.0	5.5 ± 0.5	26 ± 3.0	0.80 ± 0.03	1200 Grams

GENERAL SPECIFICATIONS

Type	Power Rating (at 70°C)	Maximum Working Voltage	Maximum Overload Voltage	Minimum Resistance	Maximum Resistance	Resistance Tolerance	Available Resistance Values
NFR16	1/6W	200V	400V	1Ω	1MΩ	±5%	E-24
NFR20	1/4W	250V	500V	1Ω	1MΩ	±5%	E-24
NFR25	1/3W	250V	500V	1Ω	10MΩ	±5%	E-24
NFR51	1/2W	350V	650V	1Ω	10MΩ	±5%	E-24
NFR52	1/2W	350V	500V	1Ω	4.7MΩ	±5%	E-24
NFR100	1W	500V	1000V	1Ω	1MΩ	±5%	E-24
NFR200	2W	500V	1000V	1Ω	1MΩ	±5%	E-24

Special sizes, values, and specifications not listed available on special order.

■ TAPING/PACKING SPECIFICATIONS

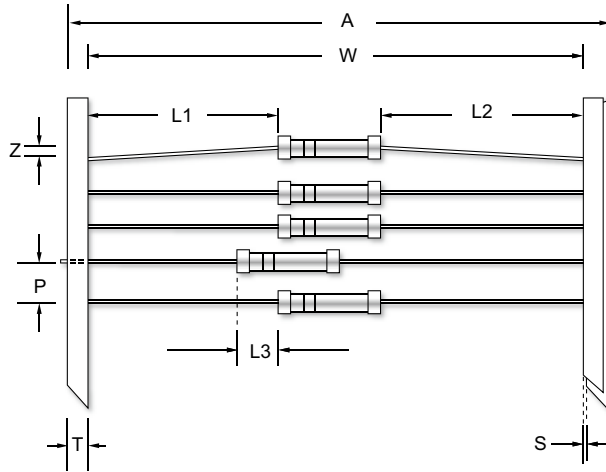

Unit (mm)

Type	A (Max.)	L1-L2 (Max.)	L3 (Max.)	P ±0.5	S (Max.)	T ±0.5	W ±1.5	Z (Max.)
NFR16	65	±1.0	0.5	5.0	0.8	6.0	52.5	1.2
NFR20	65	±1.0	0.5	5.0	0.8	6.0	52.5	1.2
NFR25	65	±1.0	0.5	5.0	0.8	6.0	52.5	1.2
NFR51	65	±1.0	0.5	5.0	0.8	6.0	52.5	1.2
NFR52	65	±1.0	0.5	5.0	0.8	6.0	52.5	1.2
NFR100	65	±1.0	0.5	5.0	0.8	6.0	52.5	1.2
NFR200	76	±1.5	1.0	10.0	0.8	6.0	63.5	1.2

Type	Packing Type	NFR16	NFR20	NFR25	NFR51	NFR52	NFR100	NFR200
Minimum Packing QTY (pcs)	Ammo pack	5000	5000	5000	2000	2000	1000	500

NFR - Non Flammable Carbon Film Resistor

Quality • Reliability
Cost-Down via Technology

NFR

■ PART NUMBER

Example: NFR16J10K0TKZTB5K0

NFR16	J	10K0	TKZ	TB5K0
Type	Tolerance	Resistance	TCR	Packaging
	J (5%)	10KΩ 4-character code containing - 3 significant digits 1 letter multiplier MULTIPLIER R = 1 K = 10 ³ M = 10 ⁶ G = 10 ⁹	3-character code TKZ = Default Product Temperature Coefficient. Information of typical product temperature coefficient can be found in the Technical Summary section of the datasheet.*	5-character code TB = Tape Box (pieces per box) <u>NFR16/20/25</u> 5K0 = 5,000 <u>NFR51/52</u> 2K0 = 2,000 <u>NFR100</u> 1K0 = 1,000 <u>NFR200</u> 500 = 500

* For the availabilities of non-default temperature coefficient, please check with us. Reference for TCR letter codes can be found in section (4) of Part Number Construction in the Appendices.

■ TECHNICAL SPECIFICATIONS

Characteristics	Limits			
Dielectric Withstanding Voltage VAC or DC	NFR16 / 20		300	
	NFR25 / 52		500	
	NFR51		700	
	NFR100 / 200		1000	
Temperature Coefficient	NFR16 /20	NFR25 /51 /52	NFR100 /200	PPM/°C
	≤ 33K	≤ 33K	≤ 56K	±300
	36K~330K	36K~330K	68K~470K	- 500
	130K~470K	360K~470K	510K~1M	- 700
	510K~910K	510K~1M	>1M	-1000
	>910K	>1M		-1500
Operating Temperature Range, °C	-55~+155			
Insulation Resistance, MΩ	10 ⁴			
Power Derating, Linear	100% at 70°C, down to zero at 155°C			

■ PERFORMANCE SPECIFICATIONS

Characteristics	Test Conditions	Limits
Short Time Over Load	IEC 60115-1 4.13 5 seconds 2.5x rated voltage (not over max. overload voltage)	±2%
Load Life In Humidity	IEC 60115-1 4.24 56 days rated load at (40±2)°C and (93±3)% relative humidity	±5%
Load Life 1,000 hours	IEC 60115-1 4.25.1 Rated load with 1.5 hours ON, 0.5 hours OFF, at (70±2)°C	±5%
Resistance To Soldering Heat	IEC 60115-1 4.18.2 Leads immersed till 3mm from the body in (260±5)°C solder for 10±1 seconds	±1%
Solderability	IEC 60115-1 4.17.2 Solder area covered after (235±3)°C/(2±0.2) seconds with flux applied	95% Min.
Vibration	IEC 60115-1 4.22 Six hours in each parallel and axial direction with a simple harmonic motion having an amplitude of 0.75mm and 10 to 500 Hz.	±1%
Thermal Endurance	IEC 60115-1 4.25.3 1000 hours at 155°C without load	±1%
Thermal Shock	IEC 60115-1 4.19 -55°C 30minutes, +155°C 30minutes, 5 cycles	±2%

NL-Series Non-inductive Resistor

Quality • Reliability
Cost-Down via Technology

NL-Series

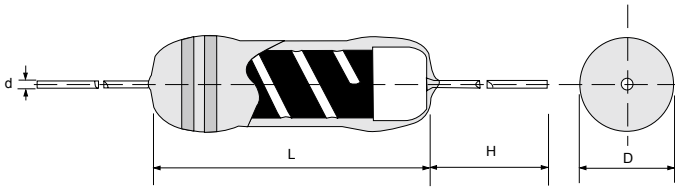

Features

- Non-inductive resistor is required by environment that demands consistent performance. With our proprietary conductive film, this NL series is designed to be low temperature coefficient and perform with low noise and virtually no inductance.
- Products meet RoHS requirements and do not contain substances of very high concern identified by European Chemicals Agency

DIMENSIONS

Type	Body Length (L, mm)	Body Diameter (D, mm)	Lead Wire Length (H, mm)	Lead Wire Diameter (d, mm)	Net Weight Per 1000Pcs
NL51	8.8 ± 1.0	3.2 ± 0.2	26 ± 3.0	0.7 ± 0.03	340 Grams
NL100	11.0 ± 1.0	4.0 ± 0.5	28 ± 3.0	0.7 ± 0.03	500 Grams
NL200	13.5 ± 1.0	5.0 ± 0.5	30 ± 3.0	0.8 ± 0.03	1050 Grams
NL300	15.5 ± 1.0	5.5 ± 0.5	30 ± 3.0	0.8 ± 0.03	1200 Grams
NL400	19.0 ± 1.0	6.0 ± 0.5	30 ± 3.0	0.8 ± 0.03	1620 Grams
NL500	19.0 ± 1.0	8.0 ± 0.5	30 ± 3.0	0.8 ± 0.03	3100 Grams
NL700	31.5 ± 1.0	8.0 ± 0.5	30 ± 3.0	0.8 ± 0.03	4000 Grams
NL1000	52.5 ± 1.5	8.0 ± 0.5	39 ± 3.0	0.8 ± 0.03	6900 Grams
NL2000	66.0 ± 2.0	8.0 ± 0.5	39 ± 3.0	0.8 ± 0.03	9000 Grams

NL1000 & NL2000 available only in bulk package.

GENERAL SPECIFICATIONS

Type	Power Rating (at 70°C)	Maximum Working Voltage	Maximum Overload Voltage	Minimum Resistance	Maximum Resistance	Resistance Tolerance	Available Resistance Values
NL51	1/2W	350V	700V	0.1 Ω	10KΩ	±1%, ±5%	E-24 / E-96
NL100	1W	350V	700V	0.1 Ω	10KΩ	±1%, ±5%	E-24 / E-96
NL200	2W	350V	700V	0.1 Ω	12KΩ	±1%, ±5%	E-24 / E-96
NL300	3W	350V	700V	0.1 Ω	15KΩ	±1%, ±5%	E-24 / E-96
NL400	4W	450V	800V	0.1 Ω	18KΩ	±1%, ±5%	E-24 / E-96
NL500	5W	500V	1000V	0.1 Ω	20KΩ	±1%, ±5%	E-24 / E-96
NL700	7W	600V	1200V	0.22 Ω	22KΩ	±1%, ±5%	E-24 / E-96
NL1000	10W	1000V	2000V	0.33 Ω	27KΩ	±1%, ±5%	E-24 / E-96
NL2000	20W	2000V	4000V	1 Ω	47KΩ	±1%, ±5%	E-24 / E-96

Special sizes, values, and specifications not listed available on special order.

POWER DERATING CURVE

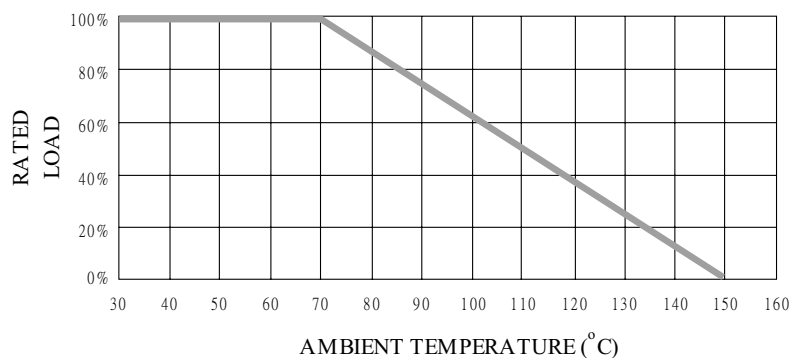

■ PART NUMBER

Example: NL200J10K0TKZTB500

NL200	J	10K0	TKZ	TB500
Type	Tolerance*	Resistance	TCR	Packaging
	F (1%) J (5%)	10KΩ 4-character code containing - 3 significant digits 1 letter multiplier <u>MULTIPLIER</u> R = 1 K = 10 ³ M = 10 ⁶ G = 10 ⁹	3-character code TKZ = Default Product Temperature Coefficient. Information of typical product temperature coefficient can be found in the Technical Summary section of the datasheet.**	5-character code TB = Tape Box (pieces per box) <u>NL51</u> 2K0 = 2,000 <u>NL100</u> 1K0 = 1,000 <u>NL200/300/400</u> 500 = 500 <u>NL500</u> 400 = 400 <u>NL700</u> 250 = 250 (Bulk Packaging Only) <u>NL1000/NL2000</u> BK + Quantity

* Listed values may not be applicable to all product types or to all resistance values. Please check with us before placing order.

**For the availabilities of non-default temperature coefficient, please check with us. Reference for TCR letter codes can be found in section (4) of Part Number Construction in the Appendices.

■ TECHNICAL SUMMARY

Characteristics	Limits	
Dielectric Withstanding Voltage, VAC or DC	NL51: NL100/ 200: NL300 to 2000:	350 600 1000
Temperature Coefficient, PPM / °C*	±100, ±300	
Operating Temperature Range, °C	-55~+150	
Insulation Resistance, MΩ	10 ⁴	

* Not applicable to all resistance values. Please check with us regarding the PPM of specific resistance value(s).

■ PERFORMANCE SPECIFICATIONS

Characteristics	Test Conditions	Limits
Short Time Over Load	IEC 60115-1 4.13 5 seconds 2.5x rated voltage (not over max. overload voltage)	±2%
Load Life In Humidity	IEC 60115-1 4.24 56 days rated load at (40±2)°C and (93±3)% relative humidity	±3%
Load Life 1,000 hours	IEC 60115-1 4.25.1 Rated load with 1.5 hours ON, 0.5 hours OFF, at (70±2)°C	±3%
Resistance To Soldering Heat	IEC 60115-1 4.18.2 Leads immersed till 3mm from the body in (260±5)°C solder for 10±1 seconds	±1%
Solderability	IEC 60115-1 4.17.2 Solder area covered after (235±3)°C/(2±0.2) seconds with flux applied	90% Min.
Vibration	IEC 60115-1 4.22 Six hours in each parallel and axial direction with a simple harmonic motion having an amplitude of 1.52mm and 10 to 2,000 Hz.	±1%
Thermal Endurance	IEC 60115-1 4.25.3 1000 hours at 150°C without load	±2%
Thermal Shock	IEC 60115-1 4.19 -55°C 30minutes, +150°C 30minutes, 5 cycles	±3%

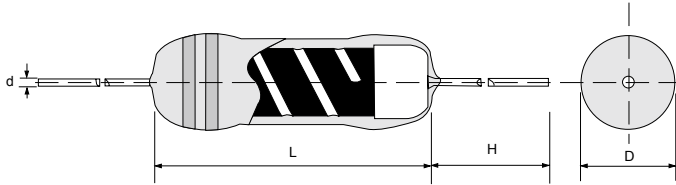

Specifications Per

- IEC 60115-1
- MIL-R-10509

Features

- Conformal multi-layer coating
- Low temperature coefficient and tolerances
- Excellent stability
- Superior power handling
- Products meet RoHS requirements and do not contain substances of very high concern identified by European Chemicals Agency

■ DIMENSIONS

Type	Body Length (L, mm)	Body Diameter (D, mm)	Lead Wire Length (H, mm)	Lead Wire Diameter (d, mm)	Net Weight Per 1000 Pcs
PMA204	3.20 ± 1.0	1.9 ± 0.2	28 ± 3.0	0.45 ± 0.02	145 Grams
PMA204T	3.20 ± 1.0	1.9 ± 0.2	28 ± 3.0	0.45 ± 0.02	145 Grams
PMA25	6.50 ± 1.0	2.4 ± 0.2	26 ± 3.0	0.55 ± 0.03	220 Grams
PMA207	6.50 ± 1.0	2.4 ± 0.2	26 ± 3.0	0.55 ± 0.03	220 Grams
PMA70	8.80 ± 1.0	3.2 ± 0.2	26 ± 3.0	0.60 ± 0.03	340 Grams
PMA100	11.0 ± 1.0	4.5 ± 0.5	26 ± 3.0	0.70 ± 0.03	600 Grams
PMA120	15.5 ± 1.0	5.5 ± 0.5	26 ± 3.0	0.80 ± 0.03	1200 Grams

■ GENERAL SPECIFICATIONS

Type	Power Rating (at 70°C)	Maximum Working Voltage	Maximum Overload Voltage	Minimum Resistance	Maximum Resistance	Resistance Tolerance	Available Resistance Values
PMA204	0.4W	250V	500V	10Ω	1MΩ	±0.1~5%	E-24~192
PMA204T	0.5W	250V	500V	10Ω	330KΩ	±0.1~5%	E-24~192
PMA25	0.25W	350V	600V	10Ω	1MΩ	±0.1~5%	E-24~192
PMA207	0.6W	350V	600V	1Ω	4.7MΩ	±0.1~5%	E-24~192
PMA70	0.7W	350V	600V	10Ω	1MΩ	±0.1~5%	E-24~192
PMA100	1.0W	500V	1000V	10Ω	1MΩ	±0.1~5%	E-24~192
PMA120	1.2W	600V	1000V	10Ω	1MΩ	±0.1~5%	E-24~192

Special sizes, values, and specifications not listed available on special order.

TAPING/PACKING SPECIFICATIONS

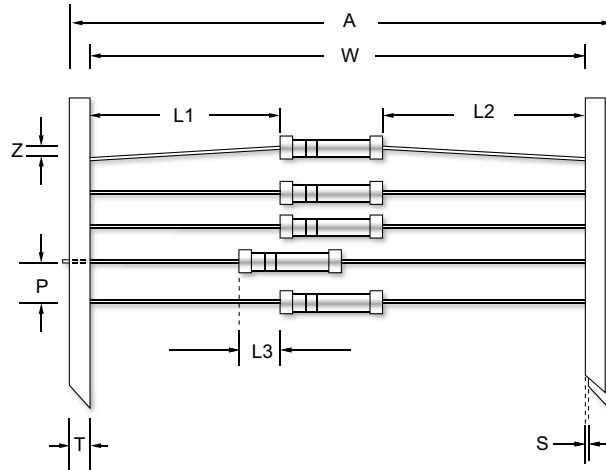

Unit (mm)

Type	A (Max.)	L1-L2 (Max.)	L3 (Max.)	P ±0.5	S (Max.)	T ±0.5	W ±1.5	Z (Max.)
PMA204	65	±1.0	0.5	5.0	0.8	6.0	52.5	1.2
PMA204T	65	±1.0	0.5	5.0	0.8	6.0	52.5	1.2
PMA25	65	±1.0	0.5	5.0	0.8	6.0	52.5	1.2
PMA207	65	±1.0	0.5	5.0	0.8	6.0	52.5	1.2
PMA70	65	±1.0	0.5	5.0	0.8	6.0	52.5	1.2
PMA100	65	±1.0	0.5	5.0	0.8	6.0	52.5	1.2
PMA120	76	±1.5	1.0	10.0	0.8	6.0	63.5	1.2

Type	Packing Type	PMA204	PMA204T	PMA25	PMA207	PMA70	PMA100	PMA120
Minimum Packing QTY (pcs)	Ammo pack	5000	5000	5000	5000	2000	1000	500

POWER DERATING CURVE

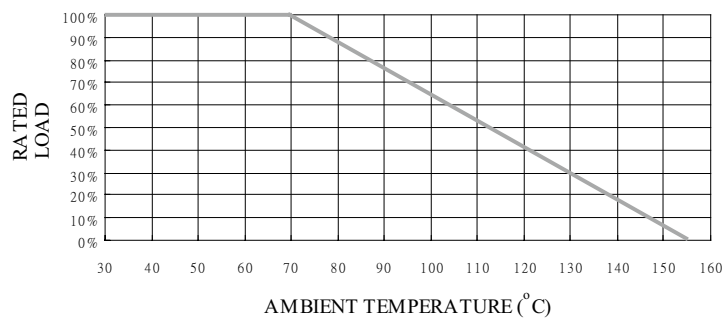

Quality • Reliability
Cost-Down via Technology

PMA

■ SURGE PERFORMANCE

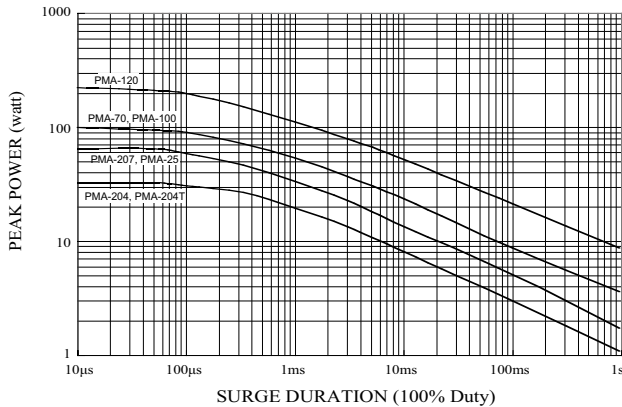
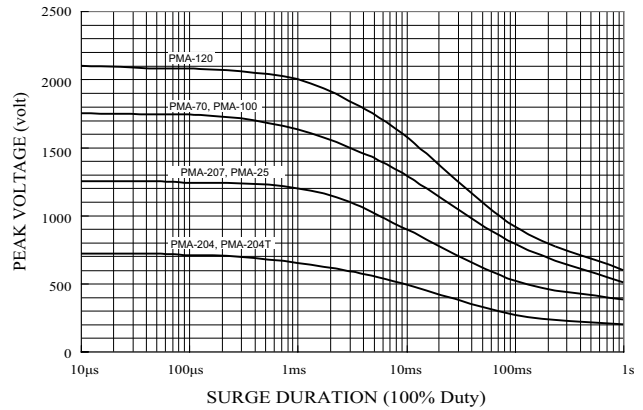
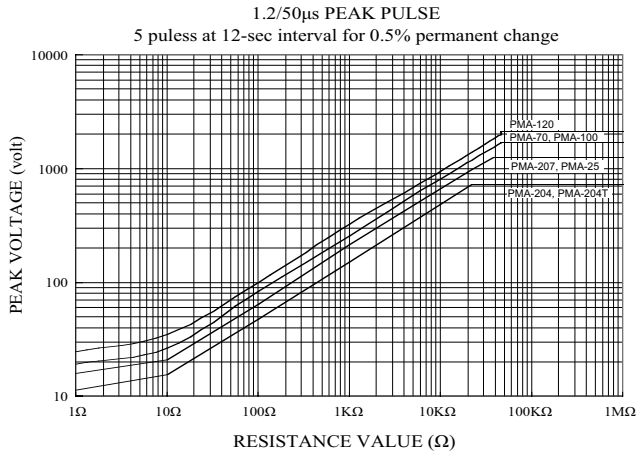

■ PART NUMBER

Example: PMA204B10K0TKQTB5K0

PMA204	B	10K0	TKQ	TB5K0
Type	Tolerance*	Resistance	TCR*	Packaging
	B (0.1%) C (0.25%) D (0.5%) F (1%) G (2%) J (5%)	10KΩ 4-character code containing - 3 significant digits 1 letter multiplier MULTIPLIER R = 1 K = 10 ³ M = 10 ⁶ G = 10 ⁹	25ppm 3-character code TKM = ± 5 ppm TKN = ± 10 ppm TKP = ± 15 ppm TKQ = ± 25 ppm TKR = ± 50 ppm TKS = ± 100 ppm	5-character code TB = Tape Box (pieces per box) <u>PM204/PMA204T/</u> <u>PMA25/PMA207</u> 5K0 = 5,000 <u>PMA70</u> 2K0 = 2,000 <u>PMA100</u> 1K0 = 1,000 <u>PMA120</u> 500 = 500

* Listed values may not be applicable across product types or to all resistance values. Please check with us before placing order.

TECHNICAL SUMMARY

Characteristics	Limits				
	PMA204 PMA204T	PMA25 PMA207	PMA70	PMA100	PMA120
Dielectric Withstanding Voltage, VAC	300	500	700	700	700
Thermal Resistance, K/W	<170	<145	<120	<95	<75
Axial Terminal Strength, N	>30	>45	>60	>70	>70
Temperature Coefficient, PPM / °C*	±5, ±10, ±15, ±20, ±25, ±50, ±100				
Operating Temperature Range, °C	-55 ~ +155				
Insulation Resistance, MΩ	>10 ⁵				
Failure Rate	<1 pcs / 10 ⁹ Device Hours				

* Not applicable to all resistance values. Please check with us regarding the PPM of specific resistance value(s).

PERFORMANCE SPECIFICATIONS

Characteristics	Test Conditions	Limits
Short Time Over Load	IEC 60115-1 4.13 6.25 times of rated power 2 seconds for PMA204 & 204T, 5 seconds for other sizes	±0.5%
Load Life In Humidity	IEC 60115-1 4.24 56 days rated load at (40±2)°C and (93±3)% relative humidity	±1%
Load Life 1000 hours	IEC 60115-1 4.25.1 Rated load with 1.5 hours ON, 0.5 hours OFF, at (70±2)°C	±1%
Resistance To Soldering Heat	IEC 60115-1 4.18.2 Leads immersed till 3mm from the body in (260±5)°C solder for 10±1 seconds	±0.5%
Solderability	IEC 60115-1 4.17.2 Solder area covered after (235±3)°C/(2±0.2) seconds with flux applied	95% Lead Coverage Min.
Vibration	IEC 60115-1 4.22 Six hours in each parallel and axial direction with a simple harmonic motion having an amplitude of 0.75mm and 10 to 500 Hz.	±0.5%
Thermal Endurance	IEC 60115-1 4.25.3 1000 hours at 155°C without load	±0.5%
Thermal Shock	IEC 60115-1 4.19 -55°C 30minutes, +155°C 30minutes, 5 cycles	±0.5%

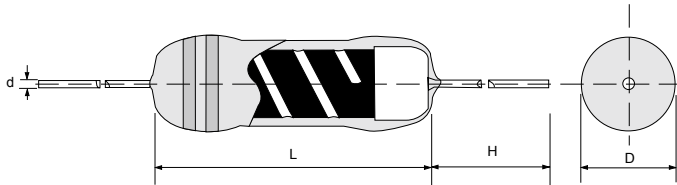

Features

- Application: high-frequency, sharp-impulse circuits.
- To protect active components in missile detonators, triac switching circuits, etc.
- Offer every better aspect of performance than carbon composition resistor.
- No "sintering effect" caused by high surge that greatly decreases resistance value.
- Replaces carbon composition resistor.
- Conformal multi-layer non-flammable coating.
- Products meet RoHS requirements and do not contain substances of very high concern identified by European Chemicals Agency

DIMENSIONS

Type	Body Length (L, mm)	Body Diameter (D, mm)	Lead Wire Length (H, mm)	Lead Wire Diameter (d, mm)	Net Weight Per 1000 Pcs
PPR16	3.20 ± 1.0	1.9 ± 0.2	28 ± 3.0	0.45 ± 0.02	145 Grams
PPR25	6.50 ± 1.0	2.6 ± 0.3	26 ± 3.0	0.55 ± 0.02	300 Grams
PPR52	6.50 ± 1.0	2.6 ± 0.3	26 ± 3.0	0.55 ± 0.02	300 Grams
PPR51	8.80 ± 1.0	3.2 ± 0.2	26 ± 3.0	0.70 ± 0.03	340 Grams
PPR100	11.0 ± 1.0	4.0 ± 0.5	28 ± 3.0	0.70 ± 0.03	500 Grams
PPR200	13.5 ± 1.0	5.0 ± 0.5	30 ± 3.0	0.80 ± 0.03	1050 Grams

GENERAL SPECIFICATIONS

Type	Power Rating (at 70°C)	Maximum Working Voltage	Maximum Permissible Surge Voltage	Minimum Resistance	Maximum Resistance	Resistance Tolerance	Available Resistance Values
PPR16	1/6W	250V	5KV	10Ω	1MΩ	±5%	E-24
PPR25	1/4W	250V	7KV	10Ω	4.7MΩ	±5%	E-24
PPR52	1/2W	250V	7KV	10Ω	4.7MΩ	±5%	E-24
PPR51	1/2W	350V	10KV	2.2Ω	4.7MΩ	±5%	E-24
PPR100	1W	350V	15KV	10Ω	4.7MΩ	±5%	E-24
PPR200	2W	400V	20KV	10Ω	4.7MΩ	±5%	E-24

Special sizes, values, and specifications not listed available on special order.

Quality • Reliability
Cost-Down via Technology

■ SURGE PERFORMANCE

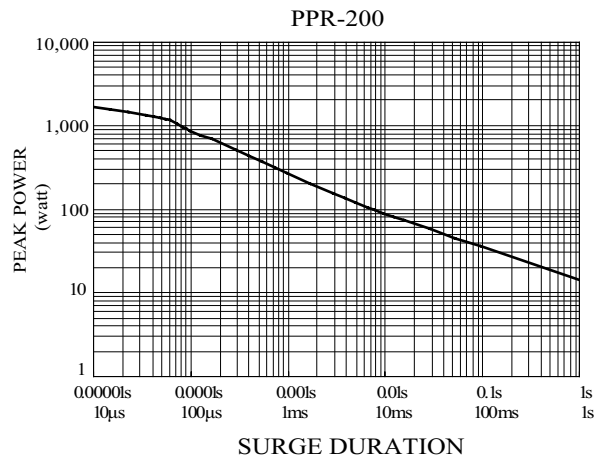
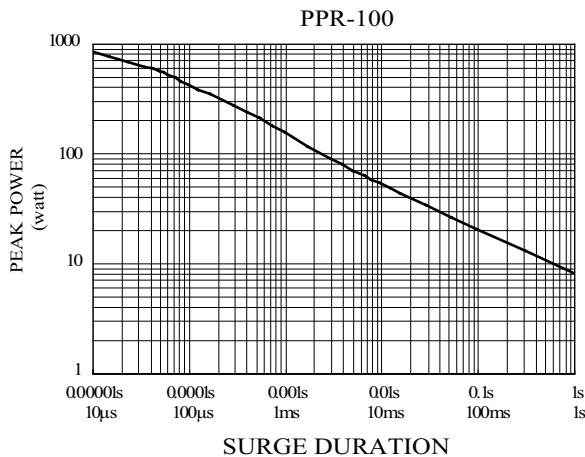
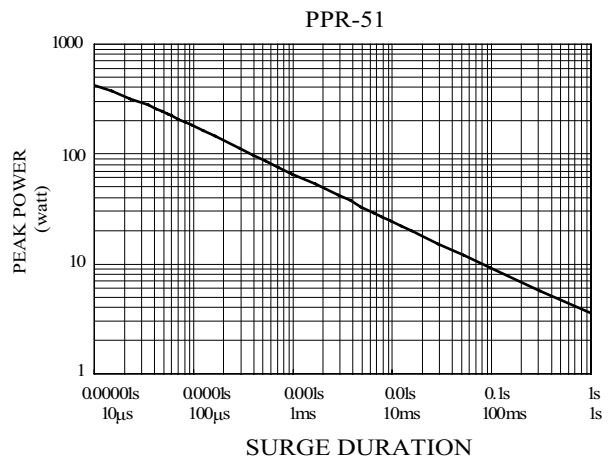
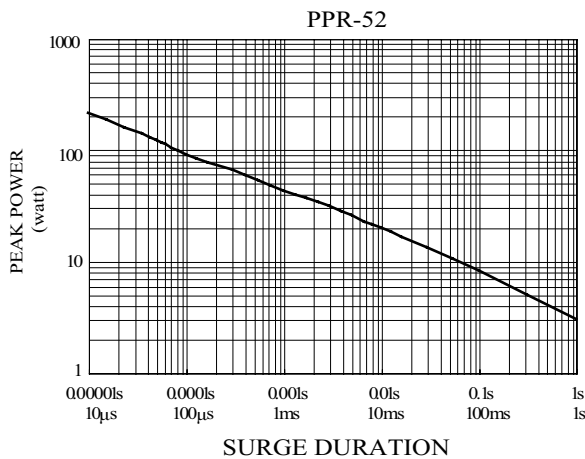
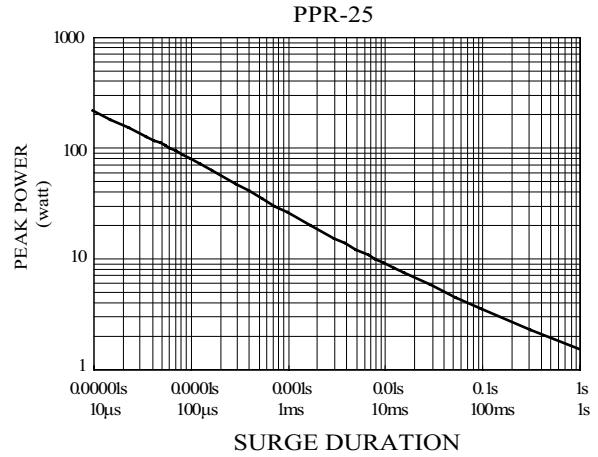
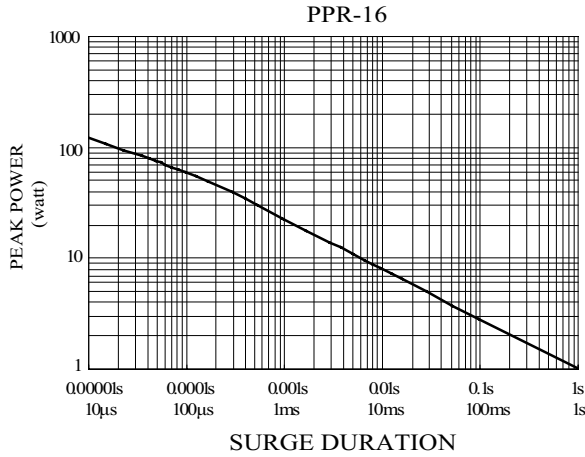

PPR

■ TECHNICAL SUMMARY

Characteristics	Limits	
Power Derating, Linear	100% at < 70°C, zero at 155°C	
Dielectric Withstanding Voltage, VAC or DC	PPR16:	300
	PPR25/ 52/ 51/ 100 :	600
	PPR200:	700
Temperature Coefficient, PPM / °C*	±750, ±1200	
Operating Temperature Range, °C	-55 ~ +155	
Insulation Resistance, MΩ	>10 ⁴	

* Not applicable to all resistance values. Please check with us regarding the PPM of specific resistance value(s).

■ PART NUMBER

Example: PPR200J10K0TKZTB500

PPR200	J	10K0	TKZ	TB500
Type	Tolerance	Resistance	TCR	Packaging
	J (5%)	10KΩ 4-character code containing - 3 significant digits 1 letter multiplier <u>MULTIPLIER</u> R = 1 K = 10 ³ M = 10 ⁶ G = 10 ⁹	3-character code TKZ = Default Product Temperature Coefficient. Information of typical product temperature coefficient can be found in the Technical Summary section of the datasheet.*	5-character code TB = Tape Box (pieces per box) <u>PPR16</u> 5K0 = 5,000 <u>PPR25/PPR52/</u> <u>PPR51</u> 2K0 = 2,000 <u>PPR100</u> 1K0 = 1,000 <u>PPR200</u> 500 = 500

* For the availabilities of non-default temperature coefficient, please check with us. Reference for TCR letter codes can be found in section (4) of Part Number Construction in the Appendices.

■ PERFORMANCE SPECIFICATIONS

Characteristics	Test Conditions	Limits		
Short Time Over Load	IEC 60115-1 4.13 5 seconds 2.5x rated voltage (not over 2X max. working voltage)	±1%		
Load Life In Humidity	IEC 60115-1 4.24 56 days rated load at (40±2)°C and (93±3)% relative humidity	±5%		
Load Life 1,000 hours	IEC 60115-1 4.25.1 Rated load with 1.5 hours ON, 0.5 hours OFF, at (70±2)°C	±5%		
Resistance To Soldering Heat	IEC 60115-1 4.18.2 Leads immersed till 3mm from the body in (260±5)°C solder for 10±1 seconds	±1%		
Solderability	IEC 60115-1 4.17.2 Solder area covered after (235±3)°C/(2±0.2) seconds with flux applied	95% Min.		
Vibration	IEC 60115-1 4.22 Six hours in each parallel and axial direction with a simple harmonic motion having an amplitude of 0.75mm and 10 to 500 Hz.	±1%		
Thermal Endurance	IEC 60115-1 4.25.3 1000 hours at 155°C without load	±1%		
Thermal Shock	IEC 60115-1 4.19 -55°C 30minutes, +155°C 30minutes, 5 cycles	±2%		
Surge Test	Surge voltage = $\sqrt{(2400 \times P \times R)}$ DC P is power rating, R is resistance value, surge voltage is not more than listed at right. Surge spec = 1.2/50µs Period = 12 sec Number of surges = 50	PPR16	5KV	5%
		PPR25	7KV	
		PPR52	7KV	
		PPR51	10KV	
		PPR100	15KV	
		PPR200	20KV	

Quality • Reliability
Cost-Down via Technology

PSR

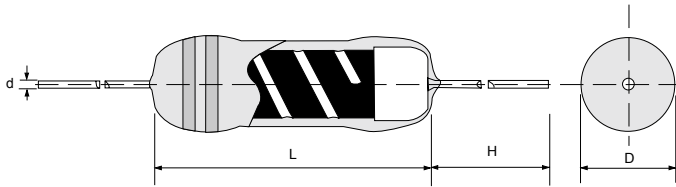

Specifications Per

- IEC 60115-4
- MIL-11804

Features

- Designed to replace cement resistors
- Reduces assembly cost with feasibility auto insertion
- Enhanced conductive film absorbs pulse noise
- Superior-grade ceramic core dissipates heat efficiently
- Flameproof multi-layer coating meets UL 94 V-0 & overload test UL 1412
- Products meet RoHS requirements and do not contain substances of very high concern identified by European Chemicals Agency

DIMENSIONS

Type	Body Length (L, mm)	Body Diameter (D, mm)	Lead Wire Length (H, mm)	Lead Wire Diameter (d, mm)	Net Weight Per 1000 Pcs
PSR650	24.0 ± 1.0	8.0 ± 0.5	30 ± 3.0	0.8 ± 0.03	3700 Grams

GENERAL SPECIFICATIONS

Type	Power Rating (at 70°C)	Maximum Working Voltage	Maximum Overload Voltage	Maximum Remissible Surge Voltage	Minimum Resistance	Maximum Resistance	Resistance Tolerance	Available Resistance Values
PSR650	6W	550V	1100V	20KV	1Ω	4.7MΩ	±5%	E-24

Special sizes, values, and specifications not listed available on special order.

SURGE PERFORMANCE

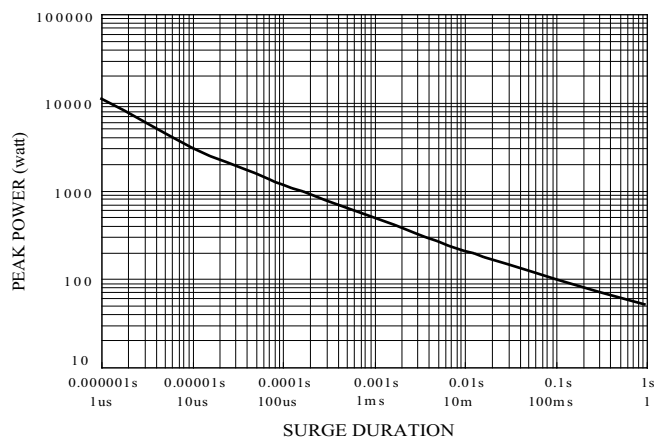

■ PART NUMBER

Example: PSR650J10K0TKZTB400

PSR650	J	10K0	TKZ	TB400
Type	Tolerance	Resistance	TCR	Packaging
	J (5%)	10KΩ 4-character code containing - 3 significant digits 1 letter multiplier <u>MULTIPLIER</u> R = 1 K = 10 ³ M = 10 ⁶ G = 10 ⁹	3-character code TKZ = Default Product Temperature Coefficient. Information of typical product temperature coefficient can be found in the Technical Summary section of the datasheet.*	5-character code TB = Tape Box (pieces per box) <u>PSR650</u> 400 = 400

* For the availabilities of non-default temperature coefficient, please check with us. Reference for TCR letter codes can be found in section (4) of Part Number Construction in the Appendices.

■ TECHNICAL SUMMARY

Characteristics	Limits
Power Derating, Linear	100% at < 70°C, zero at 155°C
Dielectric Withstanding Voltage, VAC or DC	1000
Temperature Coefficient, PPM / °C*	±750, ±1200
Operating Temperature Range, °C	-55 ~ +155
Insulation Resistance, MΩ	>10 ⁴

* Not applicable to all resistance values. Please check with us regarding the PPM of specific resistance value(s).

■ PERFORMANCE SPECIFICATIONS

Characteristics	Test Conditions	Limits	
Short Time Over Load	IEC 60115-1 4.13 5 seconds 2.5x rated voltage (not over 2X max. working voltage)	±2%	
Load Life In Humidity	IEC 60115-1 4.24 56 days rated load at (40±2)°C and (93±3)% relative humidity	±5%	
Load Life 1,000 hours	IEC 60115-1 4.25.1 Rated load with 1.5 hours ON, 0.5 hours OFF, at (70±2)°C	±5%	
Resistance To Soldering Heat	IEC 60115-1 4.18.2 Leads immersed till 3mm from the body in (260±5)°C solder for 10±1 seconds	±1%	
Solderability	IEC 60115-1 4.17.2 Solder area covered after (235±3)°C/(2±0.2) seconds with flux applied	90% Min.	
Vibration	IEC 60115-1 4.22 Six hours in each parallel and axial direction with a simple harmonic motion having an amplitude of 0.75mm and 10 to 500 Hz.	±1%	
Thermal Endurance	IEC 60115-1 4.25.3 1000 hours at 155°C without load	±2%	
Thermal Shock	IEC 60115-1 4.19 -55°C 30minutes, +155°C 30minutes, 5 cycles	±2%	
Surge Test	Surge voltage = $\sqrt{(1200 \times P \times R)}$ DC P is power rating, R is resistance value, surge voltage is not more than listed at right. Surge spec = 1.2/50µs Period = 1 sec Number of surges = 50	20KV	5%

Quality • Reliability
Cost-Down via Technology

PWR

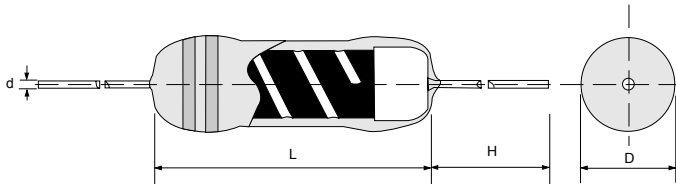

Specifications Per

- IEC 60115-1
- MIL-R-10509

Features

- Conformal multi-layer coating
- Color code per MIL & EIA standards
- Special tin-plated electrolytic copper lead wire
- Products meet RoHS requirements and do not contain substances of very high concern identified by European Chemicals Agency

DIMENSIONS

Type	Body Length (L, mm)	Body Diameter (D, mm)	Lead Wire Length (H, mm)	Lead Wire Diameter (d, mm)	Net Weight Per 1000 Pcs
PWR01	6.50 ± 1.0	2.4 ± 0.2	26 ± 3.0	0.60 ± 0.02	220 Grams
PWR02	11.0 ± 1.0	4.0 ± 0.5	28 ± 3.0	0.80 ± 0.03	220 Grams

GENERAL SPECIFICATIONS

Type	Power Rating (at 70°C)	Maximum Working Voltage	Maximum Overload Voltage	Minimum Resistance	Maximum Resistance	Resistance Tolerance	Available Resistance Values
PWR01	0.6W	350V	500V	0.22Ω	0.91Ω	±5%	E-24
	1W	350V	500V	1Ω	1MΩ	±5%	E-24
PWR02	1.2W	500V	700V	0.33Ω	0.91Ω	±5%	E-24
	2W	500V	700V	1Ω	1MΩ	±5%	E-24

Special sizes, values, and specifications not listed available on special order.

PWR01

FUSING CHARACTERISTICS
USING CONSTANT VOLTAGE

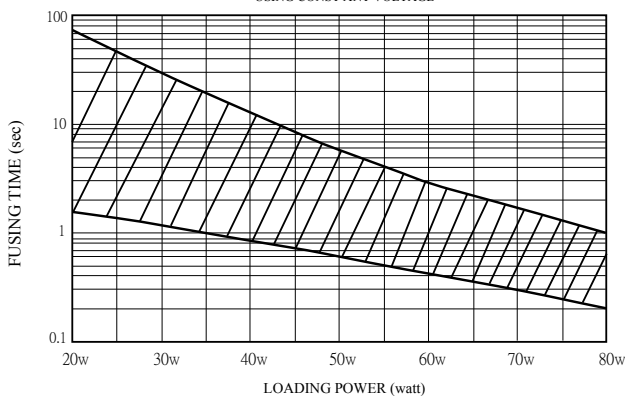

PWR02

FUSING CHARACTERISTICS
USING CONSTANT VOLTAGE

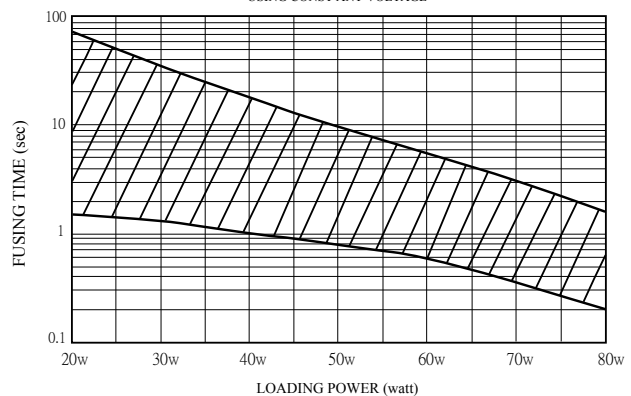

PWR Power Metal Film Resistor

Quality • Reliability
Cost-Down via Technology

■ PART NUMBER

Example: PWR01J10K0TKZTB5K0

PWR01	J	10K0	TKZ	TB5K0
Type	Tolerance	Resistance	TCR	Packaging
	J (5%)	10KΩ 4-character code containing - 3 significant digits 1 letter multiplier <u>MULTIPLIER</u> R = 1 K = 10 ³ M = 10 ⁶ G = 10 ⁹	3-character code TKZ = Default Product Temperature Coefficient. Information of typical product temperature coefficient can be found in the Technical Summary section of the datasheet.*	5-character code TB = Tape Box (pieces per box) PWR01 5K0 = 5,000 PWR02 1K0 = 1,000

* For the availabilities of non-default temperature coefficient, please check with us. Reference for TCR letter codes can be found in section (4) of Part Number Construction in the Appendices.

■ SURGE PERFORMANCE

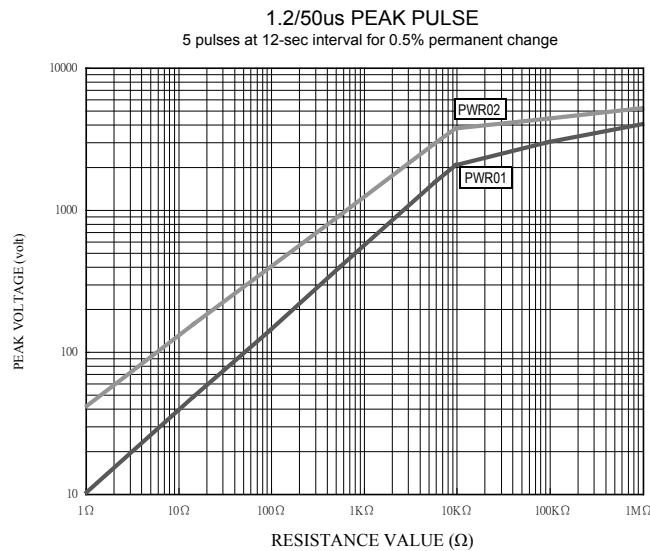

Quality • Reliability
Cost-Down via Technology

PWR

■ POWER DERATING CURVE

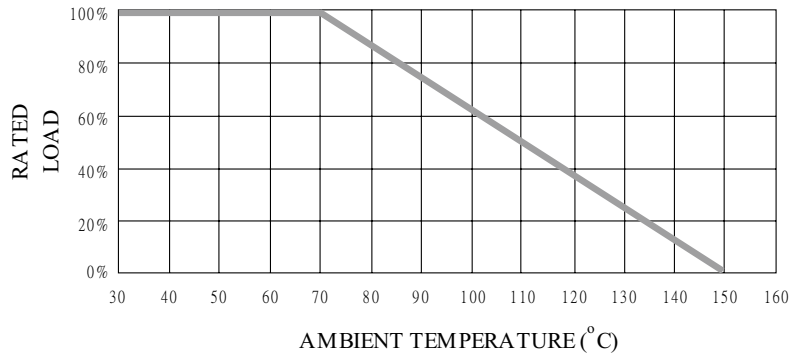

■ TECHNICAL SUMMARY

Characteristics	Limits
Dielectric Withstanding Voltage, VAC or DC	500
Temperature Coefficient, PPM / °C*	±250
Operating Temperature Range, °C	-55~+150
Insulation Resistance, MΩ	10 ⁴

* Not applicable to all resistance values. Please check with us regarding the PPM of specific resistance value(s).

■ PERFORMANCE SPECIFICATIONS

Characteristics	Test Conditions	Limits
Short Time Over Load	IEC 60115-1 4.13 5 seconds 2.5x rated voltage (not over max. overload voltage)	±3%
Load Life In Humidity	IEC 60115-1 4.24 56 days rated load at (40±2)°C and (93±3)% relative humidity	±5%
Load Life 1,000 hours	IEC 60115-1 4.25.1 Rated load with 1.5 hours ON, 0.5 hours OFF, at (70±2)°C	±5%
Resistance To Soldering Heat	IEC 60115-1 4.18.2 Leads immersed till 3mm from the body in (260±5)°C solder for 10±1 seconds	±1%
Solderability	IEC 60115-1 4.17.2 Solder area covered after (235±3)°C/(2±0.2) seconds with flux applied	95% Min.
Vibration	IEC 60115-1 4.22 Six hours in each parallel and axial direction with a simple harmonic motion having an amplitude of 1.52mm and 10 to 2,000 Hz.	±1%
Thermal Endurance	IEC 60115-1 4.25.3 1000 hours at 150°C without load	±3%
Thermal Shock	IEC 60115-1 4.19 -55°C 30minutes, +150°C 30minutes, 5 cycles	±3%

R-Series Carbon Film Fixed Resistor

Quality • Reliability
Cost-Down via Technology

R-Series

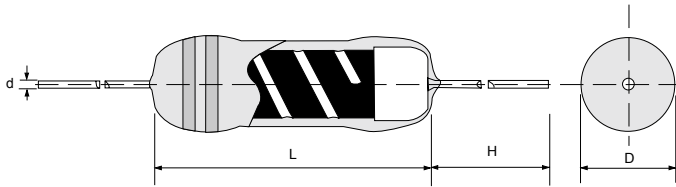

Specifications Per

- IEC 60115-1, IEC 60115-4
- MIL-R-10509

Features

- Conformal multi-layer coating (flame proof coating available)
- Color code per MIL & EIA standards
- Special tin-plated electrolytic copper lead wire
- Non-flammable coating option available
- Products meet RoHS requirements and do not contain substances of very high concern identified by European Chemicals Agency

DIMENSIONS

Type	Body Length (L, mm)	Body Diameter (D, mm)	Lead Wire Length (H, mm)	Lead Wire Diameter (d, mm)	Net Weight Per 1000 Pcs
R16	3.20 ± 1.0	1.9 ± 0.2	28 ± 3.0	0.45 ± 0.02	145 Grams
R20	3.20 ± 1.0	1.9 ± 0.2	28 ± 3.0	0.45 ± 0.02	145 Grams
R25	6.50 ± 1.0	2.4 ± 0.2	26 ± 3.0	0.55 ± 0.03	220 Grams
R51	8.80 ± 1.0	3.2 ± 0.2	26 ± 3.0	0.60 ± 0.03	340 Grams
R52	6.50 ± 1.0	2.6 ± 0.3	26 ± 3.0	0.55 ± 0.03	300 Grams
R100	11.0 ± 1.0	4.5 ± 0.5	26 ± 3.0	0.70 ± 0.03	600 Grams
R200	15.5 ± 1.0	5.5 ± 0.5	26 ± 3.0	0.80 ± 0.03	1200 Grams

GENERAL SPECIFICATIONS

Type	Power Rating (at 70°C)	Maximum Working Voltage	Maximum Overload Voltage	Minimum Resistance	Maximum Resistance	Resistance Tolerance	Available Resistance Values
R16	1/6W	200V	400V	1Ω	1MΩ	±5%	E-24
R20	1/4W	250V	500V	1Ω	1MΩ	±5%	E-24
R25	1/3W	250V	500V	1Ω	10MΩ	±5%	E-24
R51	1/2W	350V	650V	1Ω	10MΩ	±5%	E-24
R52	1/2W	350V	500V	1Ω	4.7MΩ	±5%	E-24
R100	1W	500V	1000V	1Ω	1MΩ	±5%	E-24
R200	2W	500V	1000V	1Ω	1MΩ	±5%	E-24

Special sizes, values, and specifications not listed available on special order.

TAPING/PACKING SPECIFICATIONS

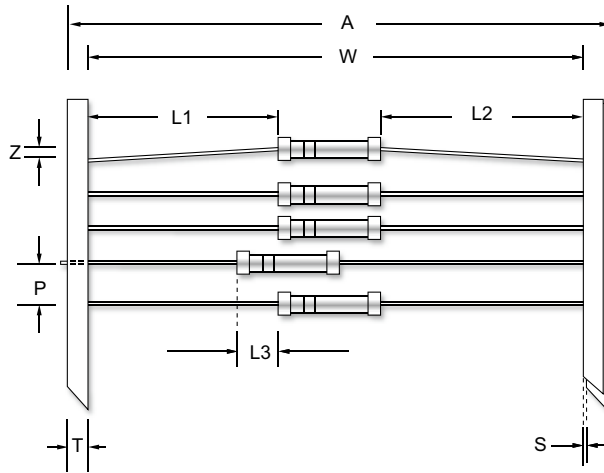

Unit (mm)

Type	A (Max.)	L1-L2 (Max.)	L3 (Max.)	P ±0.5	S (Max.)	T ±0.5	W ±1.5	Z (Max.)
R16	65	±1.0	0.5	5.0	0.8	6.0	52.5	1.2
R20	65	±1.0	0.5	5.0	0.8	6.0	52.5	1.2
R25	65	±1.0	0.5	5.0	0.8	6.0	52.5	1.2
R51	65	±1.0	0.5	5.0	0.8	6.0	52.5	1.2
R52	65	±1.0	0.5	5.0	0.8	6.0	52.5	1.2
R100	65	±1.0	0.5	5.0	0.8	6.0	52.5	1.2
R200	76	±1.5	1.0	10.0	0.8	6.0	63.5	1.2

Type	Packing Type	R16	R20	R25	R51	R52	R100	R200
Minimum Packing QTY (pcs)	Ammo pack	5000	5000	5000	2000	2000	1000	500

POWER DERATING CURVE

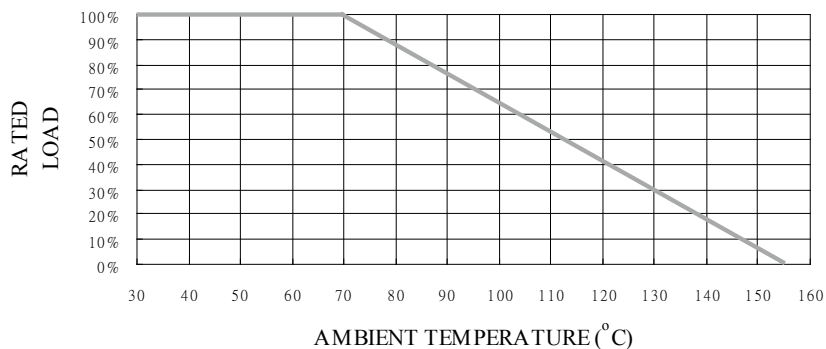

R-Series Carbon Film Fixed Resistor

Quality • Reliability
Cost-Down via Technology

R-Series

■ PART NUMBER

Example: R16J10K0TKZTB5K0

R16	J	10K0	TKZ	TB5K0
Type	Tolerance	Resistance	TCR	Packaging
	J (5%)	10KΩ 4-character code containing - 3 significant digits 1 letter multiplier <u>MULTIPLIER</u> R = 1 K = 10 ³ M = 10 ⁶ G = 10 ⁹	3-character code TKZ = Default Product Temperature Coefficient. Information of typical product temperature coefficient can be found in the Technical Summary section of the datasheet.*	5-character code TB = Tape Box (pieces per box) <u>R16/R20/R25</u> 5K0 = 5,000 <u>R51/R52</u> 2K0 = 2,000 <u>R100</u> 1K0 = 1,000 <u>R200</u> 500 = 500

* For the availabilities of non-default temperature coefficient, please check with us. Reference for TCR letter codes can be found in section (4) of Part Number Construction in the Appendices.

■ TECHNICAL SUMMARY

Characteristics	Limits			
Dielectric Withstanding Voltage, VAC or DC	R16/R20: 300			
	R25/R52: 500			
Temperature Coefficient	PPM/°C	R16/R20	R25/R51/R52	R100/R200
	±300	≤ 33K	≤ 33K	≤ 56K
	- 500	36K~330K	36K~330K	68K~470K
	- 700	130K~470K	360K~470K	510K~1M
	-1000	510K~910K	510K~1M	>1M
	-1500	>910K	>1M	
Operating Temperature Range, °C	-55 ~ +155			
Insulation Resistance, MΩ	>10 ⁴			

■ PERFORMANCE SPECIFICATIONS

Characteristics	Test Conditions	Limits
Short Time Over Load	IEC 60115-1 4.13 5 seconds 2.5x rated voltage (not over max. overload voltage)	±1%
Load Life In Humidity	IEC 60115-1 4.24 56 days rated load at (40±2)°C and (93±3)% relative humidity	±5%
Load Life 1,000 hours	IEC 60115-1 4.25.1 Rated load with 1.5 hours ON, 0.5 hours OFF, at (70±2)°C	±5%
Resistance To Soldering Heat	IEC 60115-1 4.18.2 Leads immersed till 3mm from the body in (260±5)°C solder for 10±1 seconds	±1%
Solderability	IEC 60115-1 4.17.2 Solder area covered after (235±3)°C/(2±0.2) seconds with flux applied	95% Min.
Vibration	IEC 60115-1 4.22 Six hours in each parallel and axial direction with a simple harmonic motion having an amplitude of 1.52mm and 10 to 2,000 Hz.	±1%
Thermal Endurance	IEC 60115-1 4.25.3 1000 hours at 155°C without load	±1%
Thermal Shock	IEC 60115-1 4.19 -55°C 30minutes, +155°C 30minutes, 5 cycles	±2%

R-Series MINIATURE SIZE Carbon Film Fixed Power Resistor

Quality • Reliability
Cost-Down via Technology

R-Series

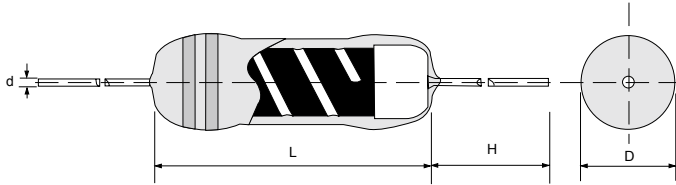

Specifications Per

- IEC 60115-1, IEC 60115-4
- MIL-R-10509

Features

- Conformal multi-layer coating
- Color code per MIL & EIA standards
- Special tin-plated electrolytic copper lead wire
- Non-flammable coating option available
- Products meet RoHS requirements and do not contain substances of very high concern identified by European Chemicals Agency

■ DIMENSIONS

Type	Body Length (L, mm)	Body Diameter (D, mm)	Lead Wire Length (H, mm)	Lead Wire Diameter (d, mm)	Net Weight Per 1000 Pcs
R100S	8.80 ± 1.0	3.2 ± 0.2	26 ± 3.0	0.60 ± 0.03	340 Grams
R200S	12.0 ± 1.0	4.5 ± 0.5	26 ± 3.0	0.70 ± 0.03	600 Grams
R300S	15.5 ± 1.0	5.5 ± 0.5	26 ± 3.0	0.80 ± 0.03	1200 Grams

■ GENERAL SPECIFICATIONS

Type	Power Rating (at 70°C)	Maximum Working Voltage	Maximum Overload Voltage	Minimum Resistance	Maximum Resistance	Resistance Tolerance	Available Resistance Values
R100S	1W	350V	650V	1Ω	10MΩ	±5%	E-24
R200S	2W	500V	1000V	1Ω	1MΩ	±5%	E-24
R300S	3W	500V	1000V	1Ω	1MΩ	±5%	E-24

Special sizes, values, and specifications not listed available on special order.

R-Series MINIATURE SIZE Carbon Film Fixed Power Resistor

Quality • Reliability
Cost-Down via Technology

■ PART NUMBER

Example: R100SJ10K0TKZTB2K0

R100S	J	10K0	TKZ	TB2K0
Type	Tolerance	Resistance	TCR	Packaging
	J (5%)	10KΩ 4-character code containing - 3 significant digits 1 letter multiplier <u>MULTIPLIER</u> R = 1 K = 10 ³ M = 10 ⁶ G = 10 ⁹	3-character code TKZ = Default Product Temperature Coefficient. Information of typical product temperature coefficient can be found in the Technical Summary section of the datasheet.*	5-character code TB = Tape Box (pieces per box) R100S 2K0 = 2,000 R200S 1K0 = 1,000 R300S 500 = 500

* For the availabilities of non-default temperature coefficient, please check with us. Reference for TCR letter codes can be found in section (4) of Part Number Construction in the Appendices.

■ TECHNICAL SUMMARY

Characteristics	Limits		
	Dielectric Withstanding Voltage, VAC or DC	R100S R200S/R300S	700 1000
Temperature Coefficient	R100S	R200S/R300S	PPM/°C
	≤33K	≤56K	±300
	36K~330K	68K~470K	- 500
	360K~470K	510K~1M	- 700
	510K~1M	>1M	-1000
Operating Temperature Range, °C	-55~+155		
Insulation Resistance, MΩ	10 ⁴		
Power Derating, Linear	100% at 70°C, down to zero at 155°C		

■ TAPING/PACKING SPECIFICATIONS

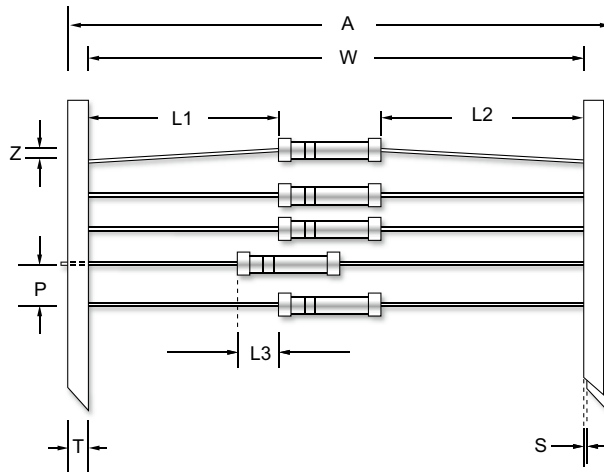

Unit (mm)

Type	A (Max.)	L1-L2 (Max.)	L3 (Max.)	P ±0.5	S (Max.)	T ±0.5	W ±1.5	Z (Max.)
R100S	65	±1.0	0.5	5.0	0.8	6.0	52.5	1.2
R200S	65	±1.0	0.5	5.0	0.8	6.0	52.5	1.2
R300S	76	±1.5	1.0	10.0	0.8	6.0	63.5	1.2

Type	Packing Type	R100S	R200S	R300S
Minimum Packing QTY (pcs)	Ammo pack	2000	1000	500

■ PERFORMANCE SPECIFICATIONS

Characteristics	Test Conditions	Limits
Short Time Over Load	IEC 60115-1 4.13 5 seconds 2.5x rated voltage (not over max. overload voltage)	±2%
Load Life In Humidity	IEC 60115-1 4.24 56 days rated load at (40±2)°C and (93±3)% relative humidity	±5%
Load Life 1,000 hours	IEC 60115-1 4.25.1 Rated load with 1.5 hours ON, 0.5 hours OFF, at (70±2)°C	±5%
Resistance To Soldering Heat	IEC 60115-1 4.18 Leads immersed till 3mm from the body in (260±5)°C solder for 10±1 seconds	±1%
Solderability	IEC 60115-1 4.17.2 Solder area covered after (235±3)°C/(2±0.2) seconds with flux applied	95% Min.
Vibration	IEC 60115-1 4.22 Six hours in each parallel and axial direction with a simple harmonic motion having an amplitude of 1.52mm and 10 to 2,000 Hz.	±1%
Terminal Endurance	IEC 60115-1 4.25.3 1000 hours at 155°C without load	±2%
Thermal Shock	IEC 60115-1 4.19 -55°C 30minutes, +155°C 30minutes, 5 cycles	±2%

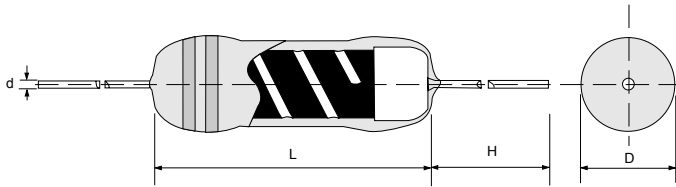

Specifications Per

• IEC 60115-1, IEC 60115-4

Features

- Advanced multi-functional design
- Cut-off on overload or accidental short circuit
- Transient withstanding for power-line coupling
- Flameproof multi-layer coating meets UL 94 V-0
- Flameproof feature meets overload test UL 1412
- Possible alternative to wire-wound resistors
- Products meet RoHS requirements and do not contain substances of very high concern identified by European Chemicals Agency

DIMENSIONS

Type	Body Length (L, mm)	Body Diameter (D, mm)	Lead Wire Length (H, mm)	Lead Wire Diameter (d, mm)	Net Weight Per 1000 Pcs
SCP50	8.80 ± 1.0	3.2 ± 0.2	28 ± 3.0	0.6 ± 0.03	340 Grams
SCP101	8.80 ± 1.0	3.2 ± 0.2	28 ± 3.0	0.6 ± 0.03	340 Grams
SCP201	11.0 ± 1.0	4.0 ± 0.5	28 ± 3.0	0.8 ± 0.03	510 grams
SCP301	13.5 ± 1.0	5.0 ± 0.5	30 ± 3.0	0.8 ± 0.03	1050 grams

GENERAL SPECIFICATIONS

Type	Power Rating (at 70°C)	Maximum Working Voltage	Maximum Overload Voltage	Minimum Resistance	Maximum Resistance	Resistance Tolerance	Available Resistance Values
SCP50	1/2W	350V	600V	2.2Ω	3.3KΩ	±5%	E-24
SCP101	1W	350V	700V	2.2Ω	3.3KΩ	±5%	E-24
SCP201	2W	350V	700V	2.2Ω	10KΩ	±5%	E-24
SCP301	3W	350V	700V	2.2Ω	10KΩ	±5%	E-24

*Please contact us for resistance values, sizes, or specifications not listed.

POWER DERATING CURVE

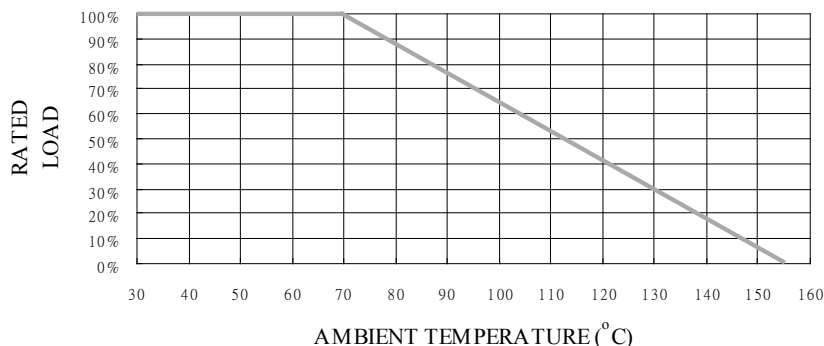

FUSING TEST SCHEME

When the SW is closed, time measure device will start to count the fusing time, and the DUT (Device Under Test) will fuse without flame.

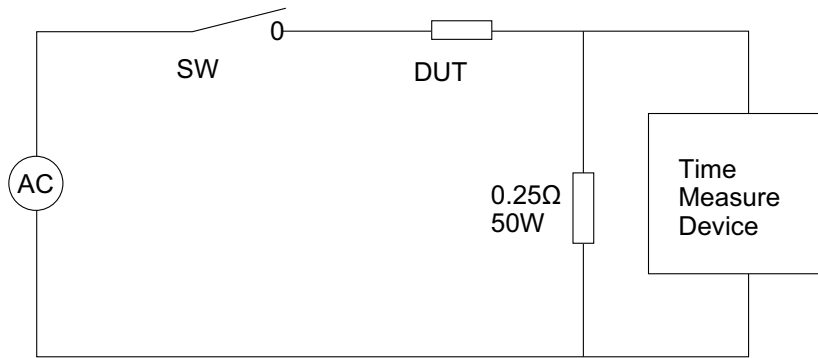

TECHNICAL SPECIFICATIONS

Characteristics		Limits	
Dielectric Withstanding Voltage, VAC or DC		SCP50/101 SCP201/301	350 700
Temperature Coefficient, PPM / °C*		Typically±400	
Operating Temperature Range, °C		-55~+155	
Fusing Condition	SCP50	Interrupts in max. 60 seconds at 12W overload	
	SCP101	Interrupts in max. 60 seconds at 16W overload	
	SCP201	Interrupts in max. 60 seconds at 20W overload	
	SCP301	Interrupts in max. 60 seconds at 30W overload	
Insulation Resistance, MΩ		10 ⁴ Min.	

* Not applicable to all resistance values. Please check with us regarding the PPM of specific resistance value(s).

PART NUMBER

Example: SCP50J10K0TKZTB2K0

SCP50	J	10K0	TKZ	TB2K0
Type	Tolerance	Resistance	TCR	Packaging
	J (5%)	10KΩ 4-character code containing - 3 significant digits 1 letter multiplier <u>MULTIPLIER</u> R = 1 K = 10 ³ M = 10 ⁶ G = 10 ⁹	3-character code TKZ = Default Product Temperature Coefficient. Information of typical product temperature coefficient can be found in the Technical Summary section of the datasheet.*	5-character code TB = Tape Box (pieces per box) <u>SCP50/SCP101</u> 2K0 = 2,000 <u>SCP201</u> 1K0 = 1,000 <u>SCP301</u> 500 = 500

* For the availabilities of non-default temperature coefficient, please check with us. Reference for TCR letter codes can be found in section (4) of Part Number Construction in the Appendices.

■ PERFORMANCE SPECIFICATIONS

Characteristics	Test Conditions	Limits
Short Time Overload	IEC 60115-1 4.13 5 seconds 2.5x rated voltage (not over max. overload voltage)	±3%
Load Life In Humidity	IEC 60115-1 4.24 56 days rated load at (40±2)°C and (93±3)% relative humidity	±5%
Load Life 1,000 hours	IEC 60115-1 4.25.1 Rated load with 1.5 hours ON, 0.5 hours OFF, at (70±2)°C	±5%
Resistance To Soldering Heat	IEC 60115-1 4.18.2 Leads immersed till 3mm from the body in (260±5)°C solder for 10±1 seconds	±1%
Solderability	IEC 60115-1 4.17.2 Solder area covered after (235±3)°C/(2±0.2) seconds with flux applied	95% Min.
Vibration	IEC 60115-1 4.22 Six hours in each parallel and axial direction with a simple harmonic motion having an amplitude of 0.75mm and 10 to 500 Hz.	±1%
Thermal Endurance	IEC 60115-1 4.25.3 1000 hours at 155°C without load	±1%
Thermal Shock	IEC 60115-1 4.19 -55°C 30minutes, +155°C 30minutes, 5 cycles	±2%

Firstohm®

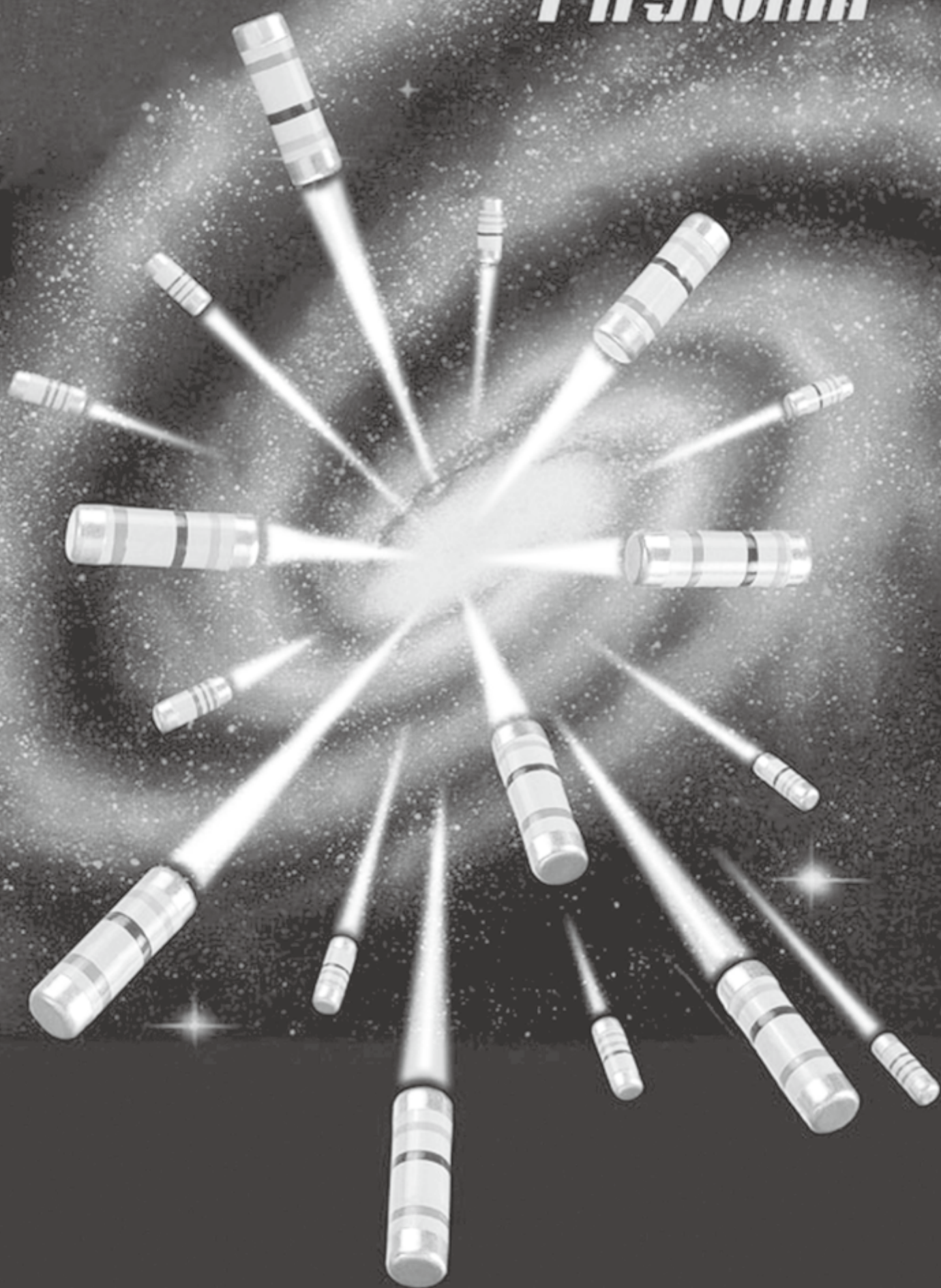

Quality • Reliability
Cost-Down via Technology

SFP

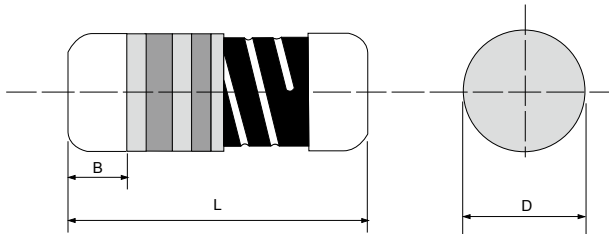

Specifications Per

• IEC 60115-1

Features

- Low temperature coefficient and tolerances
- Excellent stability
- Superior power handling
- Products meet RoHS requirements and do not contain substances of very high concern identified by European Chemicals Agency

DIMENSIONS

Type	Body Length (L, mm)	Body Diameter (D, mm)	Soldering Spot (B, mm)	Net Weight Per 1000 pcs
SFP204	3.52 ± 0.08	1.35 ± 0.1	0.6 Min.	17 grams
SFP101	5.90 ± 0.20	2.20 ± 0.1	1.0 Min.	66 grams
SFP201	8.50 ± 1.00	3.00 ± 0.2	1.3 Min.	186 grams
SFP301	10.5 ± 1.00	4.00 ± 0.5	1.6 Min.	446 grams

GENERAL SPECIFICATIONS

Type	Power Rating*	Maximum Working Voltage	Maximum Overload Voltage	Minimum Resistance	Maximum Resistance	Resistance Tolerance	Available Resistance Values
SFP204	1/2W	200V	400V	0.5Ω	10MΩ	±0.5%~5%	E-24 / E-96
SFP101	1W	350V	700V	0.5Ω	10MΩ	±0.5%~5%	E-24 / E-96
SFP201	2W	400V	800V	0.5Ω	1MΩ	±0.5%~5%	E-24 / E-96
SFP301	3W	400V	800V	0.5Ω	1MΩ	±0.5%~5%	E-24 / E-96

* At 70°C, with the exception of SFP301, derating of which starts at 40°C. Please refer to the Power Derating Curve.

* Special sizes, values, and specifications not listed available on special order.

POWER DERATING CURVE

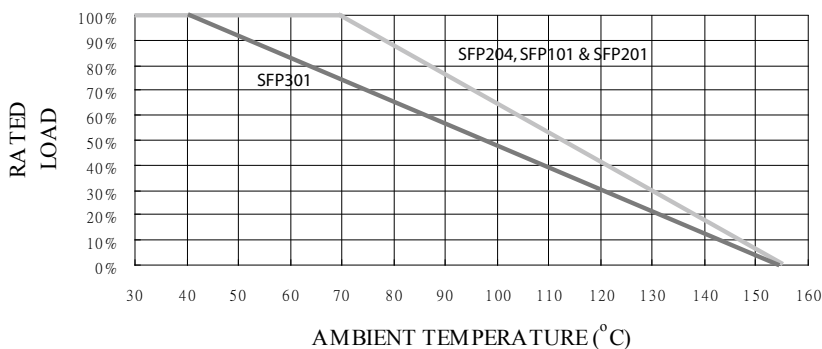

Quality • Reliability
Cost-Down via Technology

SFP

■ SUGGESTED PAD LAYOUT

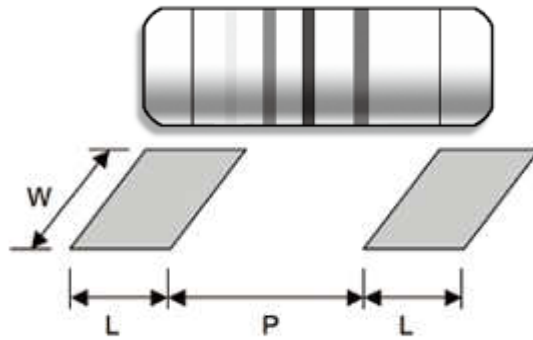

Type	Soldering Mode	Pad Length (L, mm, Min.)	Pad Spacing (P, mm)	Pad Width (W, mm, Min.)
SFP204	Reflow	1.0	2.0 ± 0.2	1.6
	Wave	1.2	2.0 ± 0.2	1.6
SFP101	Reflow	2.0	3.0 ± 0.3	3.0
	Wave	2.5	3.0 ± 0.3	3.0
SFP201	Reflow	3.0	4.9 ± 0.3	3.7
	Wave	3.5	4.8 ± 0.3	4.0
SFP301	Reflow (Not recommended)	4.0	6.2 ± 0.4	4.5
	Wave	4.5	6.0 ± 0.4	5.0

For better heat dissipation / lower heat resistance, increase W & L.

■ COVER TAPE PEELING SPECIFICATION

Recommended peeling force: SFP204, SFP101: 50±5gf SFP201, SFP301: 70±10gf

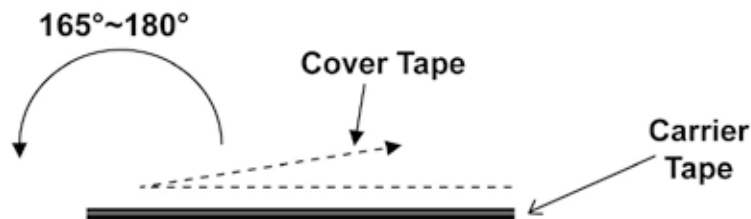

Quality • Reliability
Cost-Down via Technology

SFP

■ PART NUMBER

Example: SFP101F46R4TKSTR2K0

SFP101	F	46R4	TKS	TR2K0
Type	Tolerance*	Resistance	TCR*	Packaging
	D(0.5%) F (1%) J (5%)	46.4Ω 4-character code containing - 3 significant digits 1 letter multiplier <u>MULTIPLIER</u> R = 1 K = 10 ³ M = 10 ⁶ G = 10 ⁹	100ppm 3-character code TKR = ± 50 ppm TKS = ± 100 ppm TK2 = ± 200 ppm	5-character code TR = Tape Reel (pieces per reel) <u>SFP204</u> 3K0 = 3,000 6K0 = 6,000** 10K = 10,000** <u>SFP101</u> 2K0 = 2,000 6K0 = 6,000** 10K = 10,000** <u>SFP201</u> 2K5 = 2,500 <u>SFP301</u> 2K0 = 2,000

* Listed values may not be applicable across product types or to all resistance values. Please check with us before placing order.

** upon request

■ TECHNICAL SUMMARY

Characteristics	Limits
Dielectric Withstanding Voltage, VAC or DC	SFP204: 200 SFP101: 500 SFP201: 700 SFP301: 1000
Temperature Coefficient, PPM / °C*	±50, ±100, ±200
Operating Temperature Range, °C	-55 ~ +155
Insulation Resistance, MΩ	>10 ⁵
Failure Rate	<5 pcs / 10 ⁹ Device Hours
Tin Whisker (JESD201 Temperature Cycling & High Temp. / Humidity Storage), μm	<5

* Not applicable to all resistance values. Please check with us regarding the PPM of specific resistance value(s).

■ PERFORMANCE SPECIFICATIONS

Characteristics	Test Conditions	Limits	
Short Time Overload	IEC 60115-1 4.13 5 seconds 2.5x rated voltage (not over max. overload voltage)	±0.5%	
Load Life In Humidity	IEC 60115-1 4.24 56 days rated load at (40±2)°C and (93±3)% relative humidity	SFP204, SFP101	±0.5%
		SFP201, SFP301	±3.0%
Load Life 1,000 hours	IEC 60115-1 4.25.1 Rated load with 1.5 hours ON, 0.5 hours OFF, at (70±2)°C for SFP204, SFP101 and SFP 201;(40±2)°C for SFP301.	SFP204, SFP101	±0.5%
		SFP201, SFP301	±3.0%
Periodic Electric Overload	IEC 60115-1 4.39 3.9x rated voltage (not over max. overload voltage) with 0.1s ON, 2.5s OFF for 1,000 cycles	±1.5%	
Resistance To Soldering Heat	IEC 60115-1 4.18.2 Dip the resistor into a solder bath measured (260±5)°C and hold it for a 10±1 seconds	±0.5%	
Solderability	IEC 60115-1 4.17.2 Solder area covered after (235±3)°C/(2±0.2) seconds with flux applied	95% Min.	
Vibration	IEC 60115-1 4.22 Six hours in each parallel and axial direction with a simple harmonic motion having an amplitude of 0.75mm and 10 to 500 Hz.	±1.0%	
Thermal Endurance	IEC 60115-1 4.25.3 1000 hours at 155°C without load	±0.5%	
Thermal Shock	IEC 60115-1 4.19 -55°C 30minutes, +155°C 30minutes, 5 cycles	±1.0%	
Single pulse high voltage overload	IEC 60115-1 4.27 10 pulses of 10/700µs at 10x rated voltage (not over max. overload voltage) with interval of 60 sec.	±1%	
Electrostatic discharge (Human body model)	IEC 60115-1 4.38 3 positive & 3 negative discharges with 4KV source	±2%	
Climatic test	IEC 60115-1 4.23 4.23.2 - dry heat: 16 hours 155°C 4.23.3 - damp heat: 24 hours 55°C with 95% relative humidity 4.23.4 - cold: 2 hours -55°C 4.23.5 - negative air pressure: 2 hour 8.5KPa at (25±10)°C 4.23.6 - damp heat cyclic: 5 days 55°C with 95% relative humidity 4.23.7 - DC load: rated voltage at -55°C and 155°C each 1 Min.	±1.0%	
Bending test	IEC 60115-1 4.33 Pressing depth 2mm, 3 times	±0.5%	
Flammability	IEC 60115-1 4.35 Needle flame test 10s	No burning after 30s	

SGS Spark-Gap Surge Absorber

Quality • Reliability
Cost-Down via Technology

SGS

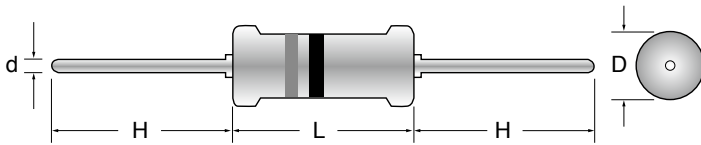

Features

- Low-cost patented construction (EP 09000962.2)
- No light-dark effect
- Low capacitance / short response time / fast ignition
- Products meet RoHS requirements and do not contain substances of very high concern identified by European Chemicals Agency

Applications

- Telephone/Fax Machine/Modem Protection
- Signal Line Protection

DIMENSIONS

Type	Body Length (L, mm)	Body Diameter (D, mm)	Lead Wire Length (H, mm)	Lead Wire Diameter (d, mm)	Net Weight Per 1000Pcs
SGS207	6.5 ± 1.0	2.4 ± 0.2	26 ± 3.0	0.55 ± 0.03	220 grams

Cross-Section View

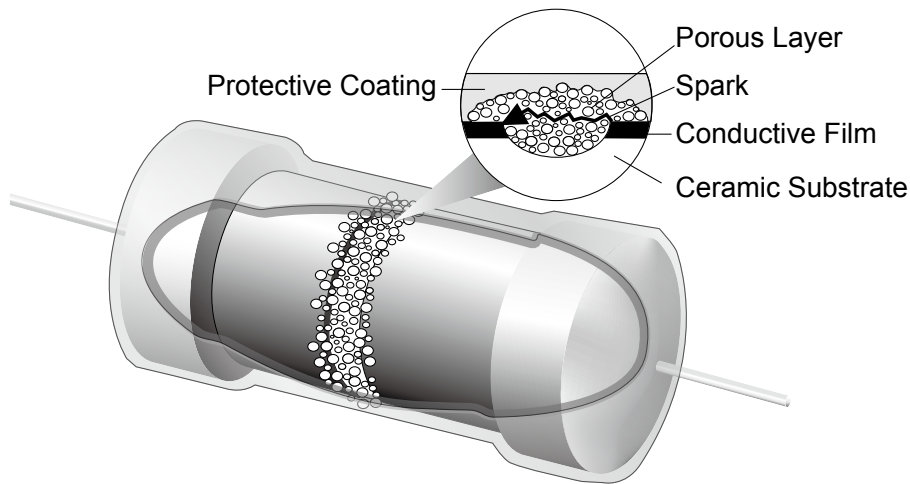

Legal Disclaimer: This international patent is covered by Paris Convention for the Protection of Industrial Property under World Intellectual Property Organization (WIPO). Breach to the patent right is prohibited.

GENERAL SPECIFICATIONS

Series	Type Name	Color Code	DC spark-over voltage
SGS207	SGS207R	White-Red	1550V ± 30%
	SGS207Y	White-Yellow	2300V ± 30%
	SGS207V	White-Violet	3300V ± 30%

■ PART NUMBER

Example: SGS207RN1550XXXTB5K0

SGS207R	N	1550	XXX	TB5K0
Type	Tolerance	Spark-Over Voltage	TCR	Packaging
	N (30%)	1550V 4-character code SGS207R: 1550V SGS207Y: 2300V SGS207V: 3300V	3-character code Parameter Not Applicable	5-character code TB = Tape Box (pieces per box) 5K0 = 5,000

■ TECHNICAL SUMMARY

Characteristics	Limits
Dielectric Withstanding Voltage, VAC or DC	500
Surge Current Capacity	60A @8/20μs (80A @2/10μs)
Operating Temperature Range, °C	-55 ~ + 155
Insulation Resistance, MΩ (Measured with DC 500V)	> 100
Capacitance	≤1pF

■ PERFORMANCE SPECIFICATIONS

Characteristics	Test Conditions	Limits
Resistance To Soldering Heat	IEC 60115-1 4.18.2 Leads immersed till 3mm from the body in (260±5)°C solder for 10±1 seconds	Rated values 40%
Solderability	IEC 60115-1 4.17.2 Solder area covered after 230±5°C/5+0.5 seconds with flux applied	95% min
Vibration	IEC 60115-1 4.22 Six hours in each parallel and axial direction with a simple harmonic motion having an amplitude of 1.52mm and 10 to 2,000 Hz.	Rated values still satisfied
Thermal Endurance	IEC 60115-1 4.25.3 1000 hours at 155°C without load	Rated values 40%
Thermal Shock	IEC 60115-1 4.19 -55°C 30minutes, +155°C 30minutes, 5 cycles	Rated values 40%
Surge Life	3000pF/ 10KV/ 0ohm, times = 300	No function failure
Bending strength	Bend lead wire, at a point 5mm apart from the root, perpendicularly to its axis by means of a 2.45N load and restore it. Repeat this step twice and check whether it has any apparent abnormality.	Rated values still satisfied

Quality • Reliability
Cost-Down via Technology

SGS

■ TAPING/PACKING SPECIFICATIONS

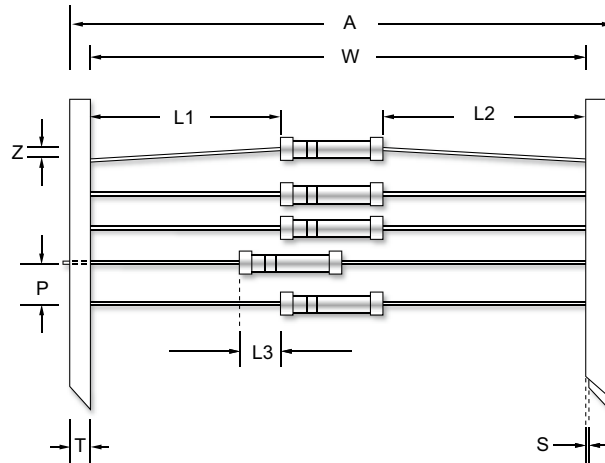

Unit (mm)

Series	A (Max.)	L1-L2 (Max.)	L3 (Max.)	P ±0.5	S (Max.)	T ±0.5	W ±1.5	Z (Max.)
SGS207	65	±1.0	0.5	5.0	0.8	6.0	52.5	1

Type	Packing Type	Minimum Packing QTY (pcs)
SGS207	Ammo Pack	5000

■ APPLICATIONS

Telephone/Fax Machine/Modem Protection (common-mode protection)

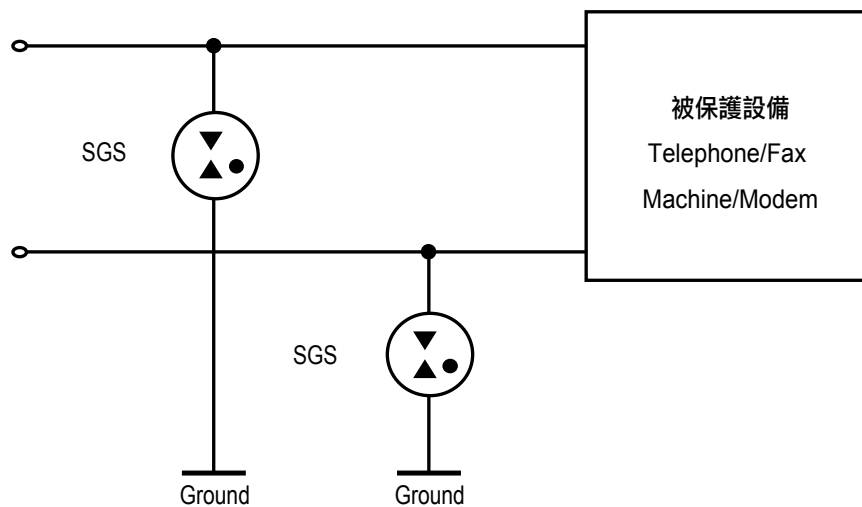

These SGS absorbers protect against common-mode interference voltages, i.e. surge voltages that appear in both exchange lines connecting to the ground. In the event of voltage overload, the SGS protects both exchange lines by conducting the surge current away to the ground.

■ APPLICATIONS

Signal Line Protection (differential-mode protection)

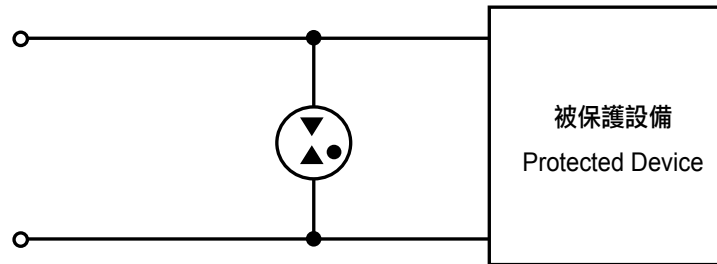

Signal circuits often run with no ground conductor. A SGS circuit located between the two signal lines offers differential mode protection by preventing the occurrence of large potential difference at the input of the equipment to be protected

Series of Spark-Gap Surge Absorber (SGS) and Metal-Oxide Varistor (MOV)

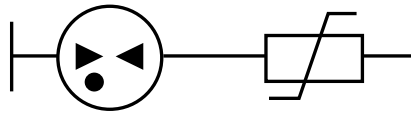

Benefits:

1. Capacitance of this branch circuit would be reduced to pF level.
2. MOV has almost no current leakage.
3. MOV aging-related issue would be greatly improved,, increasing reliability of the circuit.

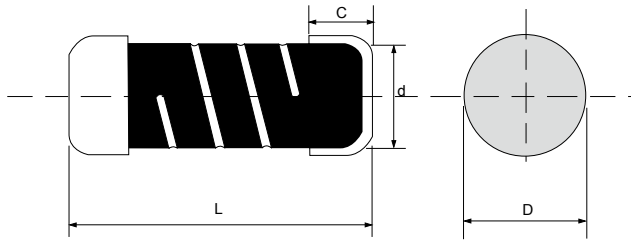

NOTE: This series will be phased out effectively March, 2015.

Features

- Specially treated metal caps withstand abrasions, impacts, and corruptions, so as to reduce contact resistance during operation. Conductive film is enhanced to withstand abrasions, impacts, and corruptions as well. Suitable for clip-in (embedded) application like switches with neon indicators, neon/LED modules, LED display array, etc.
- Products meet RoHS requirements and do not contain substances of very high concern identified by European Chemicals Agency

DIMENSIONS

Type	Body Length (L, mm)	Core Diameter (d, mm)	Cap Length (C, mm)	Body Diameter (D, mm)
SL16	3.52 ± 0.08	1.0 ± 0.05	0.6 Min.	1.35 ± 0.1
SL204	3.05 ± 0.10	1.3 ± 0.05	0.9 ± 0.05	1.60 ± 0.1
SL25	5.90 ± 0.20	1.7 ± 0.10	1.0 ± 0.10	2.20 ± 0.1
SL51	8.50 ± 1.00	2.6 ± 0.10	1.3 ± 0.10	3.00 ± 0.2

ELECTRICAL SPECIFICATIONS

Type	Power Rating (at 70°C)	Maximum Working Voltage	Maximum Overload Voltage	Tolerance	Resistance Range
SL16	1/6W	225VAC rms	350VAC rms	±5%, ±10%	1Ω ~ 1MΩ
SL204	1/6W	200VAC rms	350VAC rms	±5%, ±10%	1Ω ~ 1MΩ
SL25	1/4W	300VAC rms	600VAC rms	±5%, ±10%	1Ω ~ 4.7MΩ
SL51	1/2W	350VAC rms	700VAC rms	±5%, ±10%	10Ω ~ 9.1MΩ

Special sizes, values, and specifications not listed available on special order.

POWER DERATING CURVE

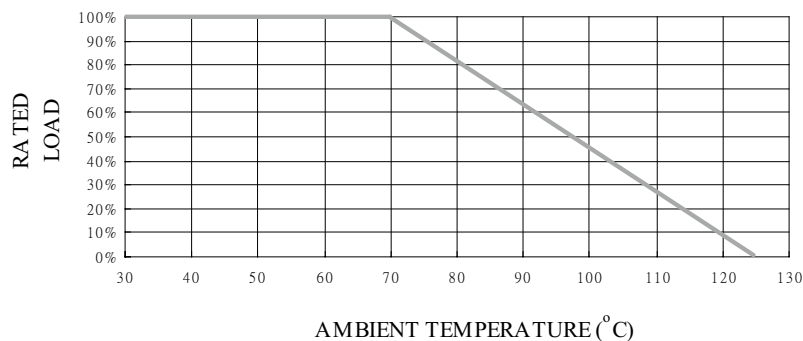

■ PART NUMBER

Example: SL204K10K0TKZBK5K0

SL204	K	10K0	TKZ	BK5K0
Type	Tolerance	Resistance	TCR	Packaging
	J (5%) K (10%)	10KΩ 4-character code containing - 3 significant digits 1 letter multiplier <u>MULTIPLIER</u> R = 1 K = 10 ³ M = 10 ⁶ G = 10 ⁹	3-character code TKZ = Default Product Temperature Coefficient. Information of typical product temperature coefficient can be found in the Technical Summary section of the datasheet.*	Bulk 5000 pieces 5-character code BK = Bulk BK + Quantity

* For the availabilities of non-default temperature coefficient, please check with us. Reference for TCR letter codes can be found in section (4) of Part Number Construction in the Appendices.

■ TECHNICAL SPECIFICATIONS

Characteristics	Limits
Temperature Coefficient, PPM / °C*	+200~-800
Operating Temperature Range, °C	-55 ~ +125

* Not applicable to all resistance values. Please check with us regarding the PPM of specific resistance value(s).

■ PERFORMANCE SPECIFICATIONS

Tests Characteristics	Test Conditions	Limits
Short Time Over Load	IEC 60115-1 4.13 5 seconds 2.5x rated voltage (not over max. overload voltage)	±1%
Load Life In Humidity	IEC 60115-1 4.24 56 days rated load at (40±2)°C and (93±3)% relative humidity	±5%
Load Life 1,000 hours	IEC 60115-1 4.25.1 Rated load with 1.5 hours ON, 0.5 hours OFF, at (70±2)°C	±5%
Resistance To Soldering Heat	IEC 60115-1 4.18.2 Dip the resistor into a solder bath measured (260±5)°C and hold it for a 10±1 seconds	±1%
Vibration	IEC 60115-1 4.22 Six hours in each parallel and axial direction with a simple harmonic motion having an amplitude of 0.75mm and 10 to 500 Hz.	±1%
Thermal Endurance	IEC 60115-1 4.25.3 1000 hours at 125°C without load	±1%
Thermal Shock	IEC 60115-1 4.19 -55°C 30minutes, +125°C 30minutes, 5 cycles	±2%

Quality • Reliability
Cost-Down via Technology

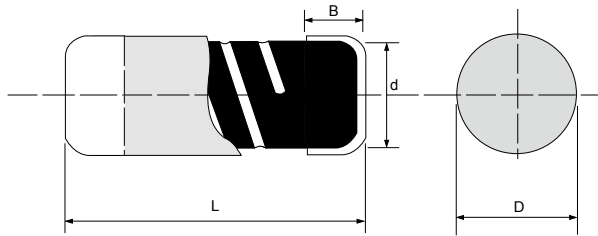

Features

- Suitable for Clip-in (embedded) application like switches with neon indicators, neon/LED modules, LED display, etc.
- Conductive film is enhanced to withstand abrasions, impacts, and corrosions as well.
- Specially treated metal caps withstand abrasions, impacts and corrosions, so as to reduce contact resistance during operation.
- Products meet RoHS requirements and do not contain substances of very high concern identified by European Chemicals Agency

DIMENSIONS

Type	Body Length (L, mm)	Core Diameter (d, mm)	Cap Length (B, mm)	Body Diameter (D, mm)
SLC16	3.52 ± 0.08	1.0 ± 0.05	0.6 Min.	1.35 ± 0.1
SLC204	3.52 ± 0.08	1.3 ± 0.05	0.6 Min.	1.35 ± 0.1
SLC25	5.90 ± 0.20	1.7 ± 0.10	1.0 Min.	2.20 ± 0.1
SLC51	8.50 ± 0.20	2.5 ± 0.10	1.3 Min.	3.00 ± 0.2

ELECTRICAL SPECIFICATIONS

Type	Power Rating (at 70°C)	Maximum Working Voltage	Maximum Overload Voltage	Tolerance	Resistance Range
SLC16	1/6W	225VAC rms	350VAC rms	±5%, ±10%	1Ω ~ 1MΩ
SLC204	1/4W	200VAC rms	350VAC rms	±5%, ±10%	1Ω ~ 1MΩ
SLC25	1/3W	300VAC rms	600VAC rms	±5%, ±10%	1Ω ~ 4.7MΩ
SLC51	1/2W	350VAC rms	700VAC rms	±5%, ±10%	10Ω ~ 9.1MΩ

Special sizes, values, and specifications not listed available on special order.

POWER DERATING CURVE

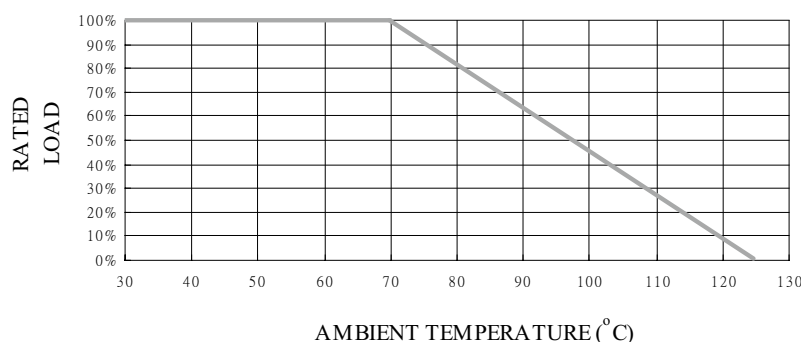

Quality • Reliability
Cost-Down via Technology

■ PART NUMBER

Example: SLC25K10K0TKZBK500

SLC25	K	10K0	TKZ	BK500
Type	Tolerance J (5%) K (10%)	Resistance 10KΩ 4-character code containing - 3 significant digits 1 letter multiplier <u>MULTIPLIER</u> R = 1 K = 10 ³ M = 10 ⁶ G = 10 ⁹	TCR 3-character code TKZ = Default Product Temperature Coefficient. Information of typical product temperature coefficient can be found in the Technical Summary section of the datasheet.*	Packaging Bulk 500 pieces 5-character code BK = Bulk BK + Quantity

* For the availabilities of non-default temperature coefficient, please check with us. Reference for TCR letter codes can be found in section (4) of Part Number Construction in the Appendices.

■ TECHNICAL SPECIFICATIONS

Characteristics	Limits
Dielectric Withstanding Voltage, VAC or DC	250
Temperature Coefficient, PPM / °C*	+200~-800
Operating Temperature Range, °C	-55 ~ +125
Insulation Resistance, MΩ	>10 ²

* Not applicable to all resistance values. Please check with us regarding the PPM of specific resistance value(s).

■ PERFORMANCE SPECIFICATIONS

Characteristics	Test Conditions	Limits
Short Time Over Load	IEC 60115-1 4.13 5 seconds 2.5x rated voltage (not over max. overload voltage)	±1%
Load Life In Humidity	IEC 60115-1 4.24 56 days rated load at (40±2)°C and (93±3)% relative humidity	±5%
Load Life 1,000 hours	IEC 60115-1 4.25.1 Rated load with 1.5 hours ON, 0.5 hours OFF, at (70±2)°C	±5%
Resistance To Soldering Heat	IEC 60115-1 4.18.2 Dip the resistor into a solder bath measured (260±5)°C and hold it for a 10±1 seconds	±1%
Vibration	IEC 60115-1 4.22 Six hours in each parallel and axial direction with a simple harmonic motion having an amplitude of 0.75mm and 10 to 500 Hz.	±1%
Thermal Endurance	IEC 60115-1 4.25.3 1000 hours at 125°C without load	±1%
Thermal Shock	IEC 60115-1 4.19 -55°C 30minutes, +125°C 30minutes, 5 cycles	±2%

SM - Stabilized Metal Film MELF Resistor

Quality • Reliability
Cost-Down via Technology

SM

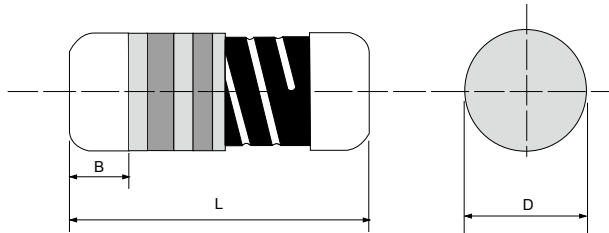

Specifications Per

- IEC 60115-1 60115-2
- EN 140401-803

Features

- SMD enabled Structure with excellent solderability
- Excellent solderability termination
- Products meet RoHS requirements and do not contain substances of very high concern identified by European Chemicals Agency

■ DIMENSIONS

Type	Body Length (L, mm)	Body Diameter (D, mm)	Soldering Spot (B, mm)	Net Weight Per 1000 pcs
SM16	3.52 ± 0.08	1.35 ± 0.1	0.6 Min.	17 grams
SM204	3.52 ± 0.08	1.35 ± 0.1	0.6 Min.	17 grams
SM207	5.90 ± 0.20	2.20 ± 0.1	1.0 Min.	66 grams
SM52	5.90 ± 0.20	2.20 ± 0.1	1.0 Min.	66 grams

■ GENERAL SPECIFICATIONS

Type	Power Rating (at 70°C)	Maximum Working Voltage	Maximum Overload Voltage	Minimum Resistance	Maximum Resistance	Resistance Tolerance	Available Resistance Values
SM16	1/6W	200V	400V	0.51Ω	10MΩ	±1%	E-24/E-96
						±2%, ±5%	E-24
SM204	1/4W	200V	400V	0.51Ω	10MΩ	±1%	E-24/E-96
						±2%, ±5%	E-24
SM207	1/3W	250V	500V	0.51Ω	10MΩ	±1%	E-24/E-96
						±2%, ±5%	E-24
SM52	1/2W	250V	500V	0.51Ω	10MΩ	±1%	E-24/E-96
						±2%, ±5%	E-24

For zero-ohm jumper, please see ZMM series. For 0.5Ω & under, please see CSM series. Special sizes, values, and specifications not listed available on special order.

TECHNICAL SUMMARY

Characteristics	Ranges & Limits	
Operating Temperature Range, °C	-55 ~ +125	
Temperature Coefficient, PPM / °C*	±1%, ±2%	±25, ±50, ±100
	±5%	±100
Dielectric Withstanding Voltage, VAC or DC	SM16, SM204	200
	SM207, SM52	500
Insulation Resistance, MΩ	>10 ⁴	
Film Temperature, °C	SM16, SM204, SM207	125
	SM52	140
Power Derating, Linear	100% for < 70 °C, down to zero at 125 °C	
Failure Rate, pcs/10 ⁹ device hours	<1	
Thermal Resistance, K/W	<220	
Tin Whisker (JESD201 Temperature Cycling & High Temp./Humidity Storage), μm	<5	

* Not applicable to all resistance values. Please check with us regarding the PPM of specific resistance value(s).

SURGE PERFORMANCE

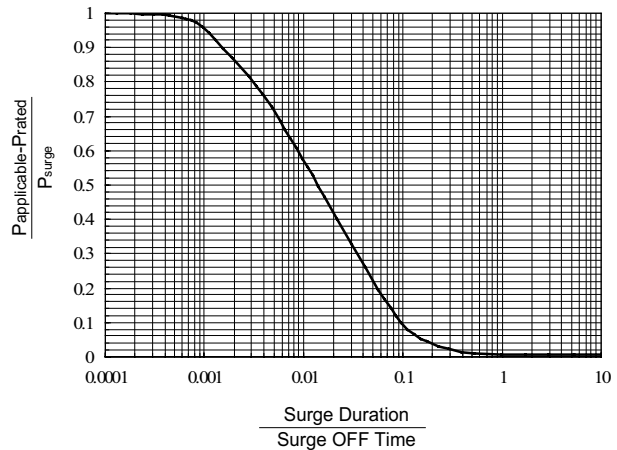
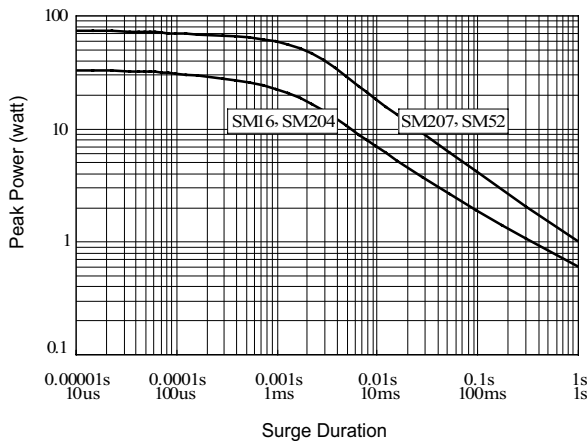

Notes:

1. SINGLE SURGE PERFORMANCE graph is good for NON REPETITIVE applications operating in an ambient temperature of 70°C or less. For temperatures above 70°C, the graph power must be derated further linearly down to zero at 125°C.
2. To determine applicable surge power in continuous-surge applications:
 - Identify allowable duration and peak power P_{surge} of single surge;
 - Determine ratio of surge duration/surge OFF time in application;
 - Calculate P_{applicable} backwardly according to Y-axis of SURGE POWER DERATING CURVE.

PERFORMANCE SPECIFICATIONS

Characteristics	Test Conditions	Limits	
Short Time Overload	IEC 60115-1 4.13 5 seconds 2.5x rated voltage (not over max. overload voltage)	0.51Ω to 332KΩ	±0.25%
		>332KΩ	±0.5%
Load Life	IEC 60115-1 4.25.1 Rated load 1000 hrs with 1.5 hours ON, 0.5 hours OFF, at (70±2)°C	0.51Ω to 332KΩ	±0.25%
		>332KΩ	±0.5%
Load Life In Humidity	IEC 60115-1 4.24 56 days rated load at (40±2)°C and (93±3)% relative humidity	±1.0%	
Load Life In Humidity (accelerated mode)	IEC 60115-1 4.37 1,000 hours at 85°C and 85% relative humidity with 0.1x rated voltage (not over 100V)	0.51Ω to <100KΩ	±1.0%
		100KΩ to 332KΩ	±2.0%
		>332KΩ	±5.0%
Periodic Electric Overload	IEC 60115-1 4.39 3.9x rated voltage (not over max. overload voltage) with 0.1s ON, 2.5s OFF for 1,000 cycles	±1.0%	
Resistance To Soldering Heat	IEC 60115-1 4.18.2 Dip the resistor into a solder bath measured (260±5)°C and hold it for a 10±1 seconds	±0.5%	
Thermal Endurance	IEC 60115-1 4.25.3 1,000 hours without load	85°C	±0.25%
		125°C	±0.5%
Thermal Shock	IEC 60115-1 4.19 -55°C 30minutes, +125°C 30minutes	5 cycles	±0.25%
		1,000 cycles	±1.5%
Single pulse high voltage overload	IEC 60115-1 4.27 • 5 pulses of 1.2/50μs at 10x rated voltage (not over 400V for SM16 & SM204; not over 500V for SM207 & SM52) with interval of 12 sec. • 10 pulses of 10/700μs at 10x rated voltage (not over 400V for SM16 & SM204; not over 500V for SM207 & SM52) with interval of 60 sec.	±0.5%	
		±0.5%	
Electrostatic discharge (Human body model)	IEC 60115-1 4.38 3 positive & 3 negative discharges with 2KV for SM16 & SM204 or 4KV for SM207 & SM52 (For continuous surge application please see Surge Performance paragraph)	±1.5%	
Climatic test	IEC 60115-1 4.23 4.23.2 - dry heat: 16 hours 125°C 4.23.3 - damp heat: 24 hours 55°C with 95% relative humidity 4.23.4 - cold: 2 hours -55°C 4.23.5 - negative air pressure: 2 hour 8.5KPa at (25±10)°C 4.23.6 - damp heat cyclic: 5 days 55°C with 95% relative humidity 4.23.7 - DC load: rated voltage at -55°C and 125°C each for 1 min.	±1.0%	
Solderability	IEC 60115-1 4.17.2 Solder area covered after (235±3)°C/(2±0.2) seconds with flux applied	> 95%	
Vibration	IEC 60115-1 4.22 Six hours in each parallel and axial direction with a simple harmonic motion having an amplitude of 1.52mm and 10 to 2,000 Hz.	±1.0%	
Bending test	IEC 60115-1 4.33 Pressing depth 2mm, 3 times	±0.25%	
Flammability	IEC 60115-1 4.35 Needle flame test 10s	No burning after 30s	

■ PART NUMBER

Example: SM204F84K5TKRTR3K0

SM204	F	84K5	TKR	TR3K0
Type	Tolerance*	Resistance	TCR*	Packaging
	F (1%) G (2%) J (5%)	84.5KΩ 4-character code containing - 3 significant digits 1 letter multiplier <u>MULTIPLIER</u> R = 1 K = 10 ³ M = 10 ⁶ G = 10 ⁹	50ppm 3-character code TKQ = ± 25ppm TKR = ± 50ppm TKS = ± 100ppm	5-character code TR = Tape Reel (pieces per reel) <u>SM16/SM204</u> 3K0 = 3,000 6K0 = 6,000** 10K = 10,000** <u>SM207/SM52</u> 2K0 = 2,000 6K0 = 6,000** 10K = 10,000**

* For the availabilities of non-default temperature coefficient, please check with us. Reference for TCR letter codes can be found in section (4) of Part Number Construction in the Appendices.

■ SUGGESTED PAD LAYOUT

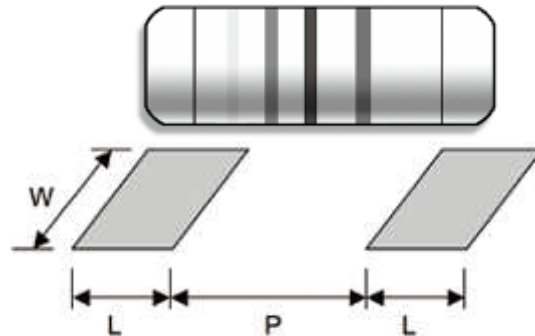

Type	Soldering Mode	Pad Length (L, mm, Min.)	Pad Spacing (P, mm)	Pad Width (W, mm, Min.)
SM16 SM204	Reflow	1.0	2.0 ± 0.2	1.6
	Wave	1.2	2.0 ± 0.2	1.6
SM207 SM52	Reflow	2.0	3.0 ± 0.3	3.0
	Wave	2.5	3.0 ± 0.3	3.0

For better heat dissipation / lower heat resistance, increase W & L.

■ COVER TAPE PEELING SPECIFICATION

Recommended peeling force: 50±gf

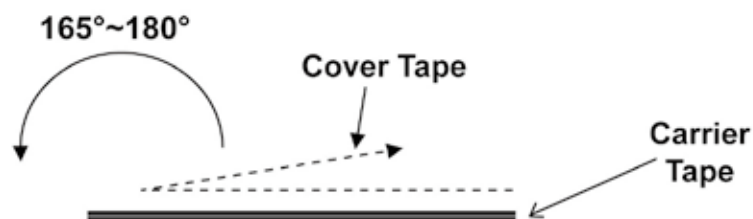

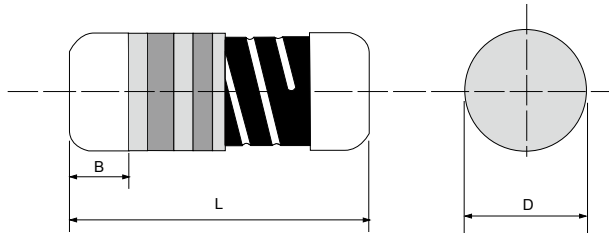

Specifications Per

• IEC 60115-1

Features

- MELF packaging yet capable of high power handling
- Special conductive film enhances anti-surge capability.
- Absorbs harmful surge which damages precious devices or components.
- SMD-enabled alternative to carbon composition resistors
- Products meet RoHS requirements and do not contain substances of very high concern identified by European Chemicals Agency

■ DIMENSIONS

Type	Body Length (L, mm)	Body Diameter (D, mm)	Soldering Spot (B, mm)	Net Weight Per 1000 pcs
SRM204	3.52 ± 0.08	1.35 ± 0.1	0.6 Min.	17 grams
SRM204T	3.52 ± 0.08	1.35 ± 0.1	0.6 Min.	17 grams
SRM207	5.90 ± 0.20	2.20 ± 0.1	1.0 Min.	66 grams
SRM207P	5.90 ± 0.20	2.20 ± 0.1	1.0 Min.	66 grams
SRM101	5.90 ± 0.20	2.20 ± 0.1	1.0 Min.	66 grams
SRM101T	5.90 ± 0.20	2.20 ± 0.1	1.0 Min.	66 grams
SRM201	8.50 ± 1.00	3.00 ± 0.2	1.3 Min.	186 grams
SRM301	10.5 ± 1.00	4.00 ± 0.5	1.6 Min.	446 grams

■ GENERAL SPECIFICATIONS

Type	Power Rating (at 70°C)	Maximum Working Voltage	Maximum Permissible Surge Voltage	Minimum Resistance	Maximum Resistance	Resistance Tolerance	Available Resistance Values
SRM204	1/4W	400V	2,000V	1Ω	1MΩ	±1%~±5%	E-24/E-96
SRM204T	1/2W	450V	4,000V	1Ω	10KΩ	±1%~±5%	E-24/E-96
SRM207	1/2W	600V	6,000V	1Ω	2M2Ω	±1%~±5%	E-24/E-96
SRM207P	1/2W	600V	8,000 V	0.1Ω	2M2Ω	±1%~±5%	E-24/E-96
SRM101	1W	600V	8,000 V	0.1Ω	2M2Ω	±1%~±5%	E-24/E-96
SRM101T	1W	600V	10,000 V	0.1Ω	2M2Ω	±1%~±5%	E-24/E-96
SRM201	2W	700V	9,000V	0.1Ω	2M2Ω	±1%~±5%	E-24/E-96
SRM301	3W	800V	10,000V	0.1Ω	2M2Ω	±1%~±5%	E-24/E-96

Special sizes, values, and specifications not listed available on special order.
For resistance values outside the specified ranges, please contact us.

Quality • Reliability
Cost-Down via Technology

■ PART NUMBER

Example: SRM204TF16R2TKZTR3K0

SRM204T	F	16R2	TKZ	TR3K0
Type	Tolerance*	Resistance	TCR	Packaging
	F (1%) J (5%)	16.2Ω 4-character code containing - 3 significant digits 1 letter multiplier <u>MULTIPLIER</u> R = 1 K = 10 ³ M = 10 ⁶ G = 10 ⁹	3-character code TKZ = Default Product Temperature Coefficient. Information of typical product temperature coefficient can be found in the Technical Summary section of the datasheet.**	5-character code TR = Tape Reel (pieces per reel) <u>SRM204/SRM204T</u> 3K0 = 3,000 6K0 = 6,000*** 10K = 10,000*** <u>SRMM207/SRM207P</u> <u>SRM101/SRM101T</u> 2K0 = 2,000 6K0 = 6,000*** 10K = 10,000*** <u>SRM201</u> 2K5 = 2,500 <u>SRM301</u> 2K0 = 2,000

* Listed values may not be applicable across product types or to all resistance values. Please check with us before placing order.

** For the availabilities of non-default temperature coefficient, please check with us. Reference for TCR letter codes can be found in section (4) of Part Number Construction in the Appendices.

*** upon request

■ POWER DERATING CURVE

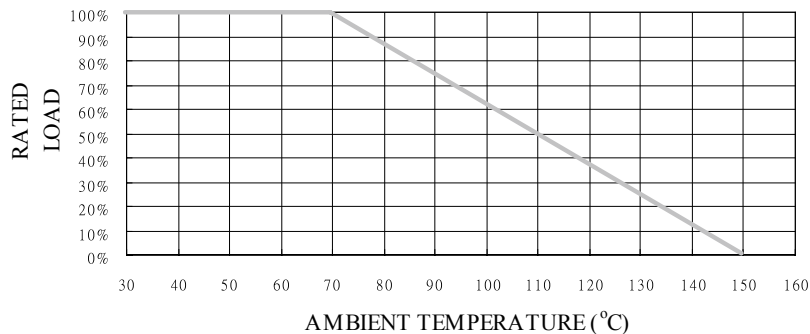

■ TECHNICAL SUMMARY

Characteristics	Ranges & Limits	
Dielectric Withstanding Voltage, VAC or DC	SRM204T SRM204/207/207P/101 SRM201/101T SRM301	300 350 500 800
Temperature Coefficient, PPM / °C*	±100, ±200, ±400	
Operating Temperature Range, °C	-55 ~ +150	
Insulation Resistance, MΩ	>10 ⁴	
Tin Whisker (JESD201 Temperature Cycling & High Temp. /Humidity Storage), μm	<5	

* Not applicable to all resistance values. Please check with us regarding the PPM of specific resistance value(s).

PERFORMANCE SPECIFICATIONS

Test Characteristics	Test Conditions	Limits		
Short Time Overload	IEC 60115-1 4.13 5 seconds 2.5x rated voltage (not over 2X max. working voltage)	±2%		
Load Life In Humidity	IEC 60115-1 4.24 56 days rated load at (40±2)°C and (93±3)% relative humidity	±5%		
Load Life 1,000 hours	IEC 60115-1 4.25.1 Rated load with 1.5 hours ON, 0.5 hours OFF, at (70±2)°C	±5%		
Periodic Electric Overload	IEC 60115-1 4.39 3.9x rated voltage (not over 2X max. working voltage) with 0.1s ON, 2.5s OFF for 1,000 cycles	±1%		
Resistance To Soldering Heat	IEC 60115-1 4.18.2 Dip the resistor into a solder bath measured (260±5)°C and hold it for a 10±1 seconds	±1%		
Solderability	IEC 60115-1 4.17.2 Solder area covered after (235±3)°C/(2±0.2) seconds with flux applied	95% Min.		
Vibration	IEC 60015-1 4.22 Six hours in each parallel and axial direction with a simple harmonic motion having an amplitude of 0.75mm and 10 to 500 Hz.	±1%		
Thermal Endurance	IEC 60115-1 4.25.3 1000 hours at 150°C without load	±1%		
Thermal Shock	IEC 60115-1 4.19 -55°C 30minutes, +150°C 30minutes, 5 cycles	±2%		
Single pulse high voltage overload	IEC 60115-1 4.27 10 pulses of 10/700µs at 10x rated voltage (not over max. overload voltage) with interval of 60 sec.	±1.0%		
Electrostatic discharge (Human body model)	IEC 60115-1 4.38 3 positive & 3 negative discharges with 4KV source	±1%		
Climatic test	IEC 60115-1 4.23 4.23.2 - dry heat: 16 hours 150°C 4.23.3 - damp heat: 24 hours 55°C with 95% relative humidity 4.23.4 - cold: 2 hours -55°C 4.23.5 - negative air pressure: 2 hour 8.5KPa at (25±10)°C 4.23.6 - damp heat cyclic: 5 days 55°C with 95% relative humidity 4.23.7 - DC load: rated voltage at -55°C and 150°C each 1 Min.	±2%		
Bending test	IEC 60115-1 4.33 Pressing depth 2mm, 3 times	±1%		
Flammability	IEC 60115-1 4.35 Needle flame test 10s	No burning after 30s		
Surge Test	Surge voltage = $\sqrt{(6000 \times P \times R)}$ DC P is power rating, R is resistance value, surge voltage is not more than listed at right Surge spec = 1.2/50µs Period = 12 sec Number of surges = 50	SRM204	2KV	±5%
		SRM204T	4KV	
		SRM207	6KV	
		SRM101/207P	8KV	
		SRM201	9KV	
		SRM301/101T	10KV	

Quality • Reliability
Cost-Down via Technology

■ SURGE PERFORMANCE

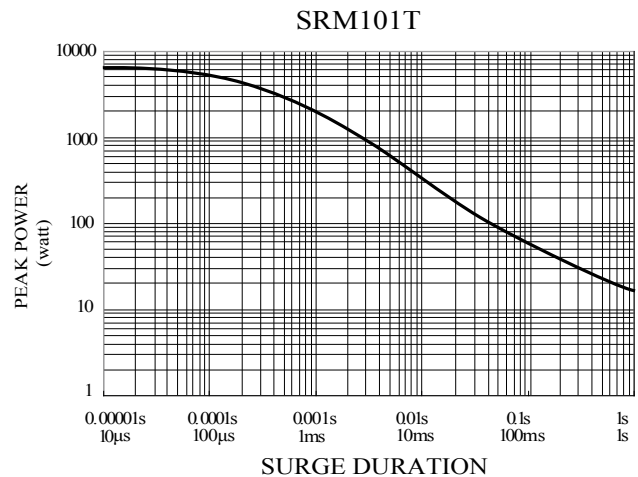
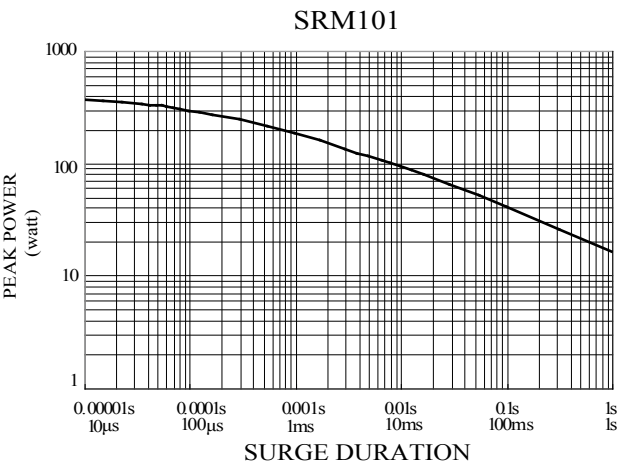
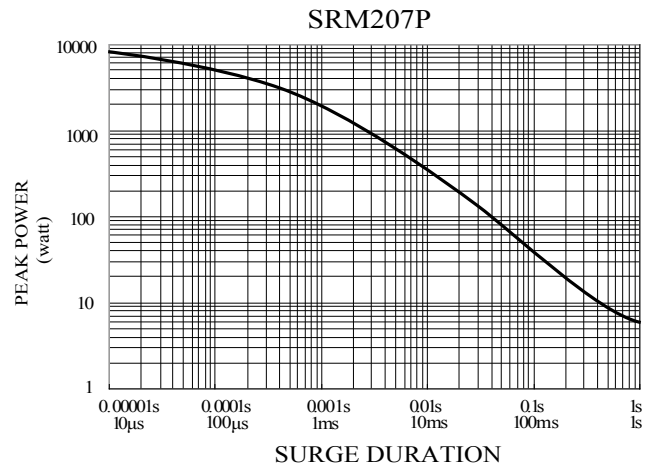
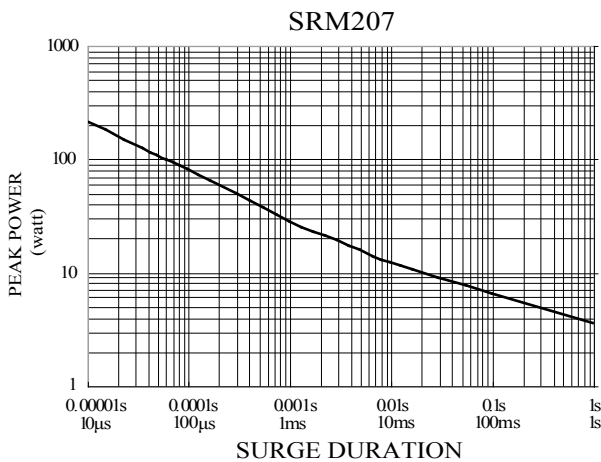
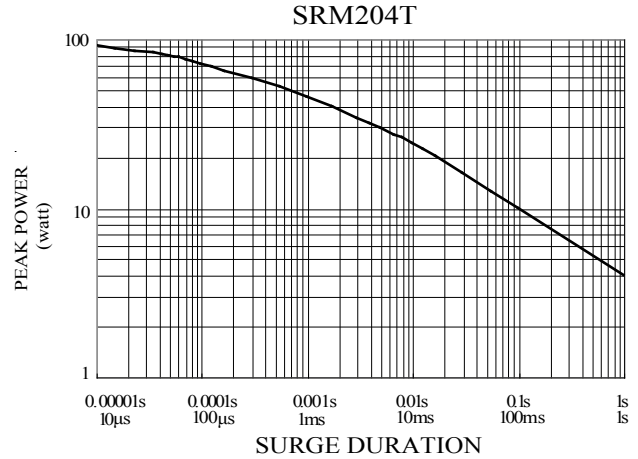
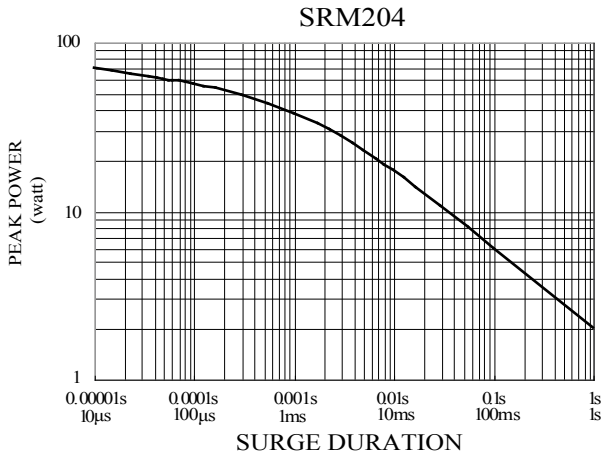

SRM

*Quality • Reliability
Cost-Down via Technology*

SRM

■ SURGE PERFORMANCE

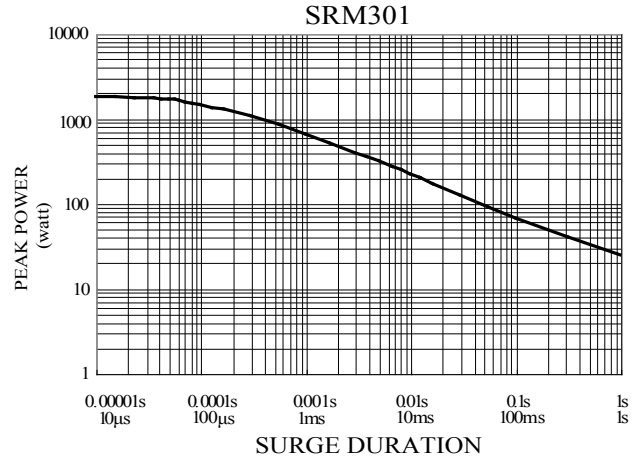
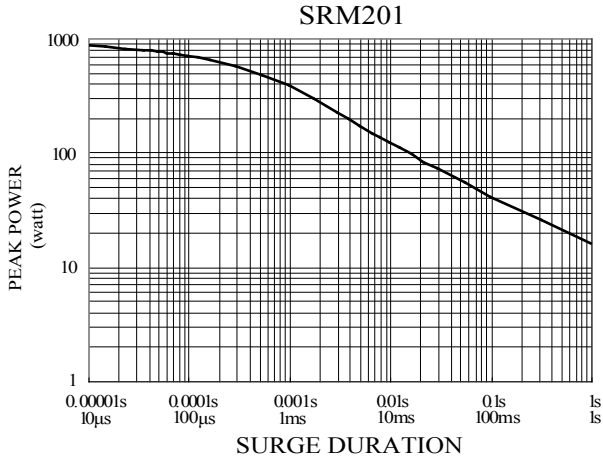

Quality • Reliability
Cost-Down via Technology

SRM

■ SUGGESTED PAD LAYOUT

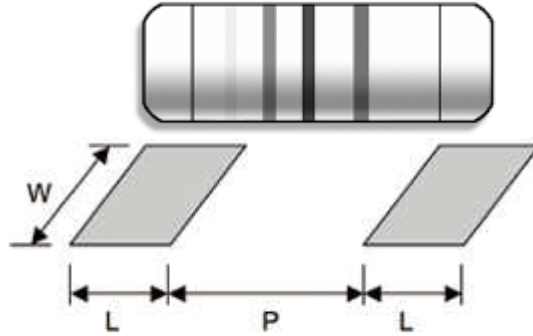

Type	Soldering Mode	Pad Length (L, mm, Min.)	Pad Spacing (P, mm)	Pad Width (W, mm, Min.)
SRM204	Reflow	1.0	2.0 ± 0.2	1.6
	Wave	1.2	2.0 ± 0.2	1.6
SRM204T	Reflow	1.0	2.0 ± 0.2	1.6
	Wave	1.2	2.0 ± 0.2	1.6
SRM207/207P	Reflow	2.0	3.0 ± 0.3	3.0
	Wave	2.5	3.0 ± 0.3	3.0
SRM101/101T	Reflow	2.0	3.0 ± 0.3	3.0
	Wave	2.5	3.0 ± 0.3	3.0
SRM201	Reflow	3.0	4.9 ± 0.3	3.7
	Wave	3.5	4.8 ± 0.3	4.0
SRM301	Reflow (Not recommended)	4.0	6.2 ± 0.4	4.5
	Wave	4.5	6.0 ± 0.4	5.0

For better heat dissipation / lower heat resistance, increase W & L.

■ COVER TAPE PEELING SPECIFICATION

Recommended peeling force:

SRM204, SRM204T, SRM207, SRM207P, SRM101, SRM101T: 50±5gf SRM201, SRM301: 70±10gf

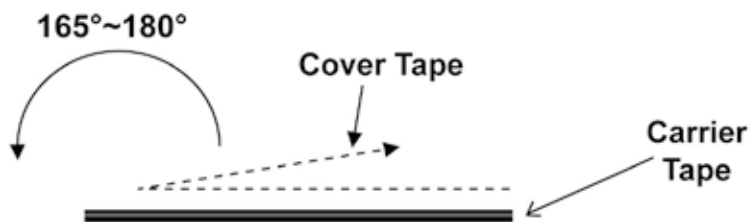

SRS Spark-Noise Suppression Slug Resistor

Quality • Reliability
Cost-Down via Technology

SRS

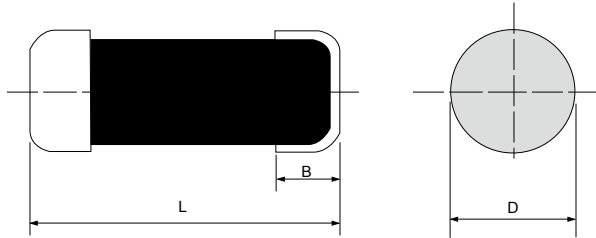

Features

- Dedicatedly designed for high-voltage spark ignition systems. Proprietary conductive film withstands high-voltage surge impacts with long-term stability. One of few sources in the world capable of manufacturing such type of resistor.
- Products meet RoHS requirements and do not contain substances of very high concern identified by European Chemicals Agency
- **This type will be phased out effectively March, 2015 and replaced by ISC (Ignition Noise Suppression Resistor-Composite Film/Ceramic and ISW (Ignition Noise Suppression Resistor-Wirewound)**

DIMENSIONS

Type	Body Length (L, mm)	Body Diameter (D, mm)	Cap Length (B, mm)	Net Weight Per 1000 pcs
SRS20K	10.5 ± 1	3.8 ± 0.5	2.2 ± 0.3	390 grams
SRS35K	16.0 ± 1	4.5 ± 0.3	2.2 ± 0.2	700 grams
SRS50K	18.5 ± 1	4.5 ± 0.3	2.2 ± 0.2	700 grams
SRS50K1	18.5 ± 1	5.5 ± 0.5	2.5 ± 0.2	1200 grams

GENERAL SPECIFICATIONS

Type	Power Rating (at 70°C)	Maximum Working Voltage	Maximum Surge Load	Minimum Resistance	Maximum Resistance	Resistance Tolerance	Available Resistance Values
SRS20K	1/2W	350V	20KV / 10nS	10Ω	22KΩ	±5% ~ ±20%	E-6/E-24
SRS35K	2W	350V	35KV / 20nS	1KΩ	10KΩ	±5% ~ ±20%	E-6/E-24
SRS50K	3W	400V	50KV / 20nS	1KΩ	10KΩ	±5% ~ ±20%	E-6/E-24
SRS50K1	4W	450V	50KV / 30nS	1KΩ	33KΩ	±5% ~ ±20%	E-6/E-24

Special sizes, values, and specifications not listed available on special order.

TECHNICAL SPECIFICATIONS

Characteristics	Limits
Dielectric Withstanding Voltage, VAC or DC	5SRS20K SRS35K SRS50K SRS50K1 500
Temperature Coefficient, PPM / °C*	Typically ± 1200
Operating Temperature Range, °C	-55~+155
Insulation Resistance, MΩ	>10 ⁴

* Not applicable to all resistance values. Please check with us regarding the PPM of specific resistance value(s).

SURGE TEST

Type	Circuit	Load	Period	Surges
SRS20K	20KV	20nS	20mS	200,000
SRS35K	35KV	30nS	20mS	200,000
SRS50K	50KV	30nS	20mS	200,000
SRS50K1	50KV	45nS	20mS	200,000

Quality • Reliability
Cost-Down via Technology

■ PART NUMBER

Example: SRS35KJ10K0TKZBK500

SRS35K	J	10K0	TKZ	BK500
Type	Tolerance	Resistance	TCR	Packaging
	J (5%) K (10%)	10KΩ 4-character code containing - 3 significant digits 1 letter multiplier <u>MULTIPLIER</u> R = 1 K = 10 ³ M = 10 ⁶ G = 10 ⁹	3-character code TKZ = Default Product Temperature Coefficient. Information of typical product temperature coefficient can be found in the Technical Summary section of the datasheet.*	Bulk 500 pieces 5-character code BK = Bulk BK + Quantity

* For the availabilities of non-default temperature coefficient, please check with us. Reference for TCR letter codes can be found in section (4) of Part Number Construction in the Appendices.

■ PERFORMANCE SPECIFICATIONS

Characteristics	Test Conditions	Limits
Short Time Overload	IEC 60115-1 4.13 5 seconds 2.5x rated voltage (not over 2X max. working voltage)	±1%
Load Life In Humidity	IEC 60115-1 4.24 56 days rated load at (40±2)°C and (93±3)% relative humidity	±3%
Load Life 1,000 hours	IEC 60115-1 4.25.1 Rated load with 1.5 hours ON, 0.5 hours OFF, at (70±2)°C	±2%
Vibration	IEC 60115-1 4.22 Six hours in each parallel and axial direction with a simple harmonic motion having an amplitude of 1.52mm and 10 to 2,000 Hz.	±1%
Thermal Endurance	IEC 60115-1 4.25.3 1000 hours at 155°C without load	±1%
Thermal Shock	IEC 60115-1 4.19 -55°C 30minutes, +155°C 30minutes, 5 cycles	±1%
Surge Test	200,000 impacts at period 20mS (3000rpm/1hour) according to the following chart.	-5%~+2%

■ SURGE DIAGRAM

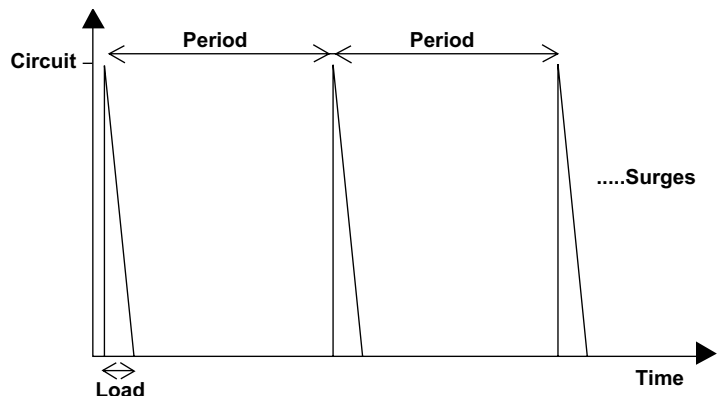
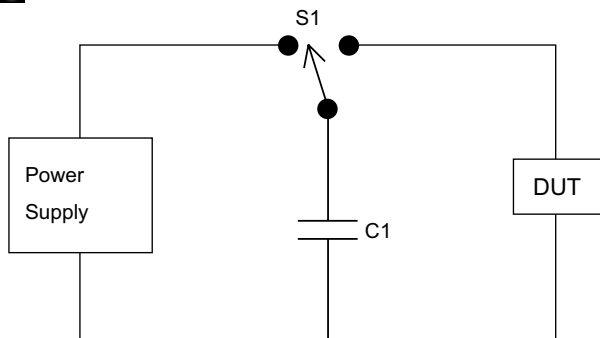

S1: High-voltage insulated switch

C1: High-voltage variable capacitor

Power supply: Variable 0 ~ 50KV DC

DUT: Device Under Test.

SSR Surge Safety Resistor

Quality • Reliability
Cost-Down via Technology

SSR

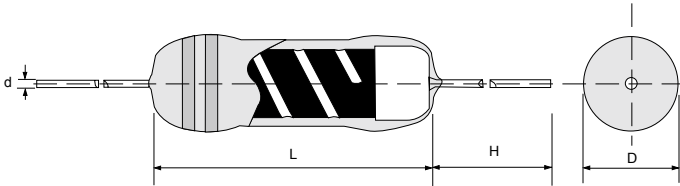

Features

- Designed to replace carbon or ceramic composition resistor, SSR series is applied in high-surge applications such as fuel ignition systems, power charging/ discharging circuits, TV sets, etc, to absorb harmful surge energy, so to prevent hazard of fire and circuit damage caused by surge energy with a flame-proof coating.
- Products meet RoHS requirements and do not contain substances of very high concern identified by European Chemicals Agency

DIMENSIONS

Type	Body Length (L, mm)	Body Diameter (D, mm)	Lead Wire Length (H, mm)	Lead Wire Diameter (d, mm)	Net Weight Per 1000 Pcs
SSR16	3.20 ± 1.0	1.9 ± 0.2	28 ± 3.0	0.45 ± 0.02	145 Grams
SSR25	6.50 ± 1.0	2.6 ± 0.3	26 ± 3.0	0.55 ± 0.02	300 Grams
SSR51	8.80 ± 1.0	3.2 ± 0.2	26 ± 3.0	0.60 ± 0.03	340 Grams
SSR100	11.0 ± 1.0	4.0 ± 0.5	28 ± 3.0	0.70 ± 0.03	500 Grams
SSR200	15.5 ± 1.0	5.0 ± 0.5	30 ± 3.0	0.80 ± 0.03	1150 Grams
SSR300	15.5 ± 1.0	5.5 ± 0.5	30 ± 3.0	0.80 ± 0.03	1200 Grams

GENERAL SPECIFICATIONS

Type	Power Rating (at 70°C)	Maximum Working Voltage	Maximum Permissible Surge Voltage	Minimum Resistance	Maximum Resistance	Resistance Tolerance	Available Resistance Values
SSR16	1/6W	250V	7.5KV	10Ω	180KΩ	±5%	E-24
SSR25	1/4W	250V	10KV	10Ω	180KΩ	±5%	E-24
SSR51	1/2W	300V	15KV	10Ω	220KΩ	±5%	E-24
SSR100	1W	350V	20KV	10Ω	220KΩ	±5%	E-24
SSR200	2W	400V	22.5KV	10Ω	240KΩ	±5%	E-24
SSR300	3W	400V	25KV	10Ω	240KΩ	±5%	E-24

Special sizes, values, and specifications not listed available on special order.

Quality • Reliability
Cost-Down via Technology

■ SURGE PERFORMANCE

SSR16

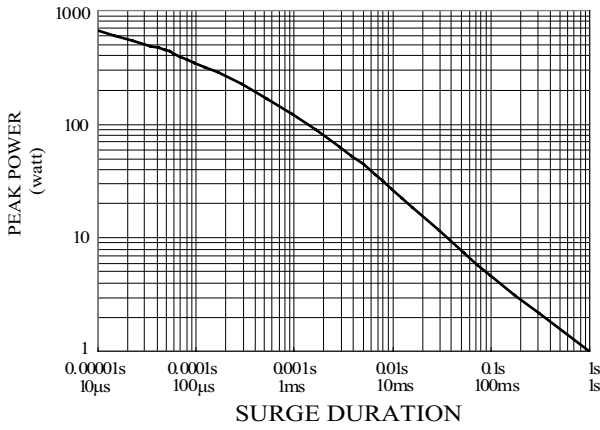

SSR25

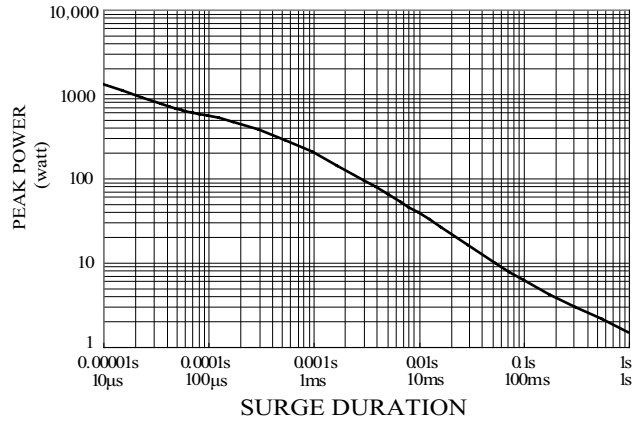

SSR51

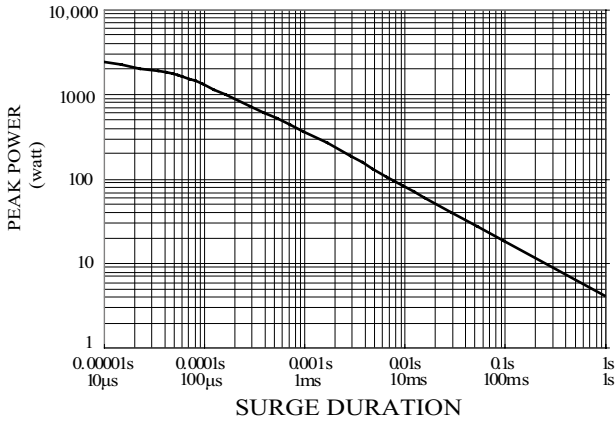

SSR100

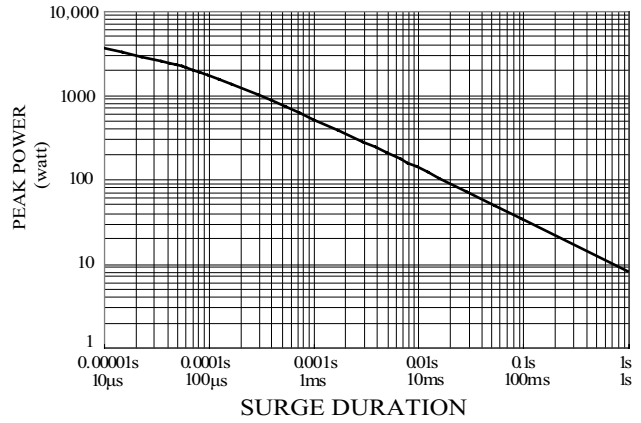

SSR200

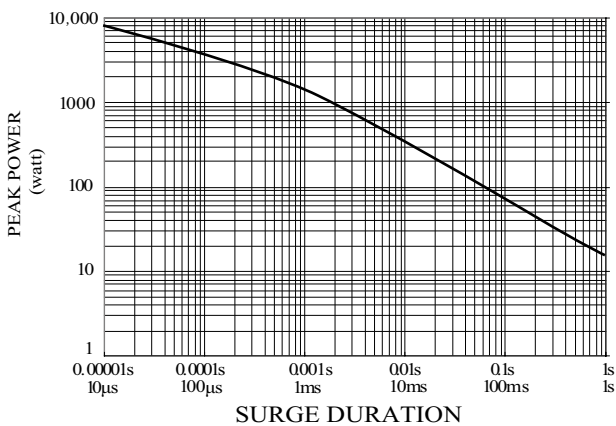

SSR300

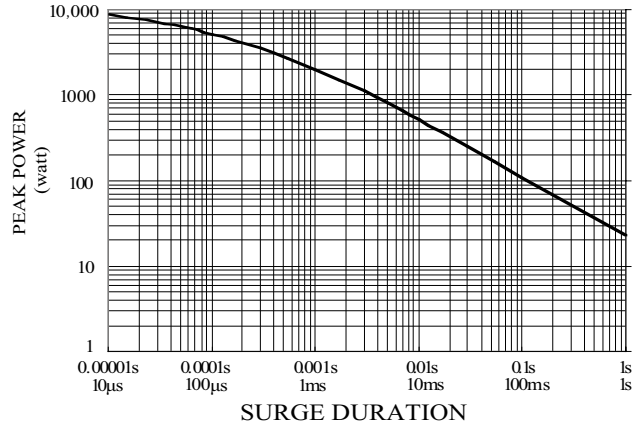

SSR

SSR Surge Safety Resistor

Quality • Reliability
Cost-Down via Technology

SSR

■ PART NUMBER

Example: SSR200J10K0TKZTB500

SSR200	J	10K0	TKZ	TB500
Type	Tolerance	Resistance	TCR	Packaging
	J (5%)	10KΩ 4-character code containing - 3 significant digits 1 letter multiplier <u>MULTIPLIER</u> R = 1 K = 10 ³ M = 10 ⁶ G = 10 ⁹	3-character code TKZ = Default Product Temperature Coefficient. Information of typical product temperature coefficient can be found in the Technical Summary section of the datasheet.*	5-character code TB = Tape Box (pieces per box) SSR16 5K0 = 5,000 SSR25/SSR51 2K0 = 2,000 SSR100 1K0 = 1,000 SSR200/300 500 = 500

* For the availabilities of non-default temperature coefficient, please check with us. Reference for TCR letter codes can be found in section (4) of Part Number Construction in the Appendices.

■ TECHNICAL SUMMARY

Characteristics	Limits	
Power Derating, Linear	100% at < 70°C, zero at 150°C	
Dielectric Withstanding Voltage, VAC or DC	SSR16 SSR25 /51 /100 SSR200 SSR300	300 600 700 800
Temperature Coefficient, PPM / °C*	SSR16 /25 /100 /200 /300: SSR51:	±600 ±750
Operating Temperature Range, °C	-55~+150	
Insulation Resistance, MΩ	>10 ⁴	

* Not applicable to all resistance values. Please check with us regarding the PPM of specific resistance value(s).

Quality • Reliability
Cost-Down via Technology

■ PERFORMANCE SPECIFICATIONS

Characteristics	Test Conditions	Limits		
Short Time Over Load	IEC 60115-1 4.13 5 seconds 2.5x rated voltage (not over 2X max. working voltage)	±1%		
Load Life In Humidity	IEC 60115-1 4.24 56 days rated load at (40±2)°C and (93±3)% relative humidity	±5%		
Load Life 1,000 hours	IEC 60115-1 4.25.1 Rated load with 1.5 hours ON, 0.5 hours OFF, at (70±2)°C	±5%		
Resistance To Soldering Heat	IEC 60115-1 4.18.2 Leads immersed till 3mm from the body in (260±5)°C solder for 10±1 seconds	±1%		
Solderability	IEC 60115-1 4.17.2 Solder area covered after (235±3)°C/(2±0.2) seconds with flux applied	1/6W&1/4W	95% Min.	
		1/2W to 3W	90% Min.	
Vibration	IEC 60115-1 4.22 Six hours in each parallel and axial direction with a simple harmonic motion having an amplitude of 1.52mm and 10 to 2,000 Hz.	±1%		
Thermal Endurance	IEC 60115-1 4.25.3 1000 hours at 150°C without load	±1%		
Thermal Shock	IEC 60115-1 4.19 -55°C 30minutes, +150°C 30minutes, 5 cycles	±2%		
Surge Test	Surge voltage = $\sqrt{(6000 \times P \times R)}$ DC P is power rating, R is resistance value, surge voltage is not more than listed at right. Surge spec = 1.2/50µs Period = 12 sec Number of surges = 3000	SSR16	7.5KV	5%
		SSR25	10 KV	
		SSR51	15 KV	
		SSR100	20 KV	
		SSR200	22.5 KV	
		SSR300	25 KV	

SSR

Quality • Reliability
Cost-Down via Technology

SSR

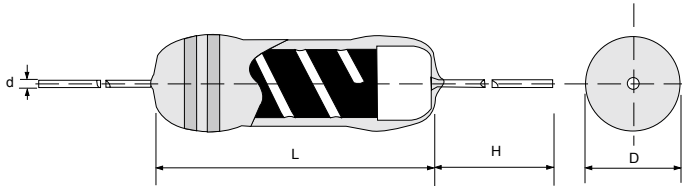

Features

- Designed to replace carbon or ceramic composition resistor, SSR series is applied in high-surge applications such as fuel ignition systems, power charging/discharging circuits, TV sets, etc, to absorb harmful surge energy, so to prevent hazard of fire and circuit damage caused by surge energy with a flame-proof coating.
- Products meet RoHS requirements and do not contain substances of very high concern identified by European Chemicals Agency

DIMENSIONS

Type	Body Length (L, mm)	Body Diameter (D, mm)	Lead Wire Length (H, mm)	Lead Wire Diameter (d, mm)	Net Weight Per 1000 Pcs
SSR400	19.0 ± 1.0	6.0 ± 0.5	30 ± 3.0	0.8 ± 0.03	1600 Grams
SSR500	24.0 ± 1.0	8.0 ± 0.5	30 ± 3.0	0.8 ± 0.03	3700 Grams

GENERAL SPECIFICATIONS

Type	Power Rating (at 70°C)	Maximum Working Voltage	Maximum Permissible Surge Voltage	Minimum Resistance	Maximum Resistance	Resistance Tolerance	Available Resistance Values
SSR400	4W	500V	30KV	10Ω	270KΩ	±5%	E-24
SSR500	5W	600V	35KV	10Ω	330KΩ	±5%	E-24

Special sizes, values, and specifications not listed available on special order.

TECHNICAL SPECIFICATIONS

Characteristics	Limits	
Power Derating, Linear	100% at < 70°C, zero at 150°C	
Dielectric Withstanding Voltage, VAC or DC	800	
Temperature Coefficient, PPM / °C*	SSR400	±750
	SSR500	±600
Operating Temperature Range, °C	-55~+150	
Insulation Resistance, MΩ	10 ⁴	

* Not applicable to all resistance values. Please check with us regarding the PPM of specific resistance value(s).

SURGE PERFORMANCE

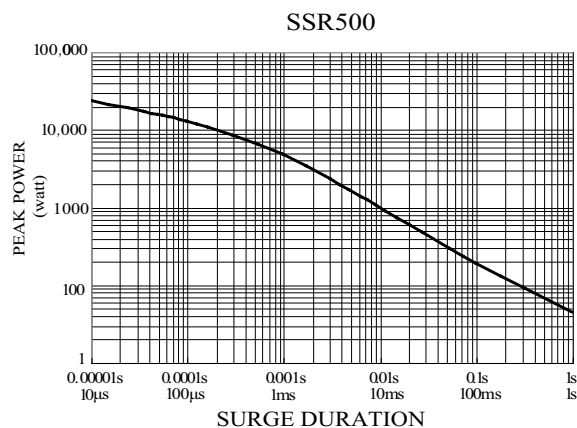
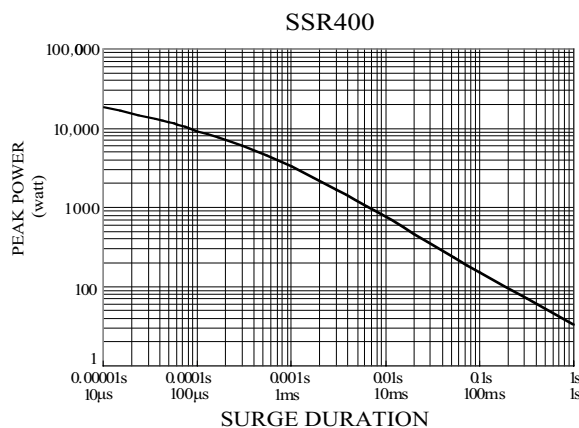

Quality • Reliability
Cost-Down via Technology

■ PART NUMBER

Example: SSR400J10K0TKZTB400

SSR400	J	10K0	TKZ	TB400
Type	Tolerance	Resistance	TCR	Packaging
	J (5%)	10KΩ 4-character code containing - 3 significant digits 1 letter multiplier <u>MULTIPLIER</u> R = 1 K = 10 ³ M = 10 ⁶ G = 10 ⁹	3-character code TKZ = Default Product Temperature Coefficient. Information of typical product temperature coefficient can be found in the Technical Summary section of the datasheet.*	5-character code TB = Tape Box (pieces per box) SSR400 500 = 500 SSR500 250 = 250

* For the availabilities of non-default temperature coefficient, please check with us. Reference for TCR letter codes can be found in section (4) of Part Number Construction in the Appendices.

■ PERFORMANCE SPECIFICATIONS

Characteristics	Test Conditions	Limits		
Short Time Over Load	IEC 60115-1 4.13 5 seconds 2.5x rated voltage (not over 2X max. working voltage)	±2%		
Load Life In Humidity	IEC 60115-1 4.24 56 days rated load at (40±2)°C and (93±3)% relative humidity	±5%		
Load Life 1,000 hours	IEC 60115-1 4.25.1 Rated load with 1.5 hours ON, 0.5 hours OFF, at (70±2)°C	±5%		
Resistance To Soldering Heat	IEC 60115-1 4.18.2 Leads immersed till 3mm from the body in (260±5)°C solder for 10±1 seconds	±1%		
Solderability	IEC 60115-1 4.17.2 Solder area covered after (235±3)°C/(2±0.2) seconds with flux applied	90% Min.		
Vibration	IEC 60115-1 4.22 Six hours in each parallel and axial direction with a simple harmonic motion having an amplitude of 1.52mm and 10 to 2,000 Hz.	±1%		
Thermal Endurance	IEC 60115-1 4.25.3 1000 hours at 150°C without load	±1%		
Thermal Shock	IEC 60115-1 4.19 -55°C 30minutes, +150°C 30minutes, 5 cycles	±3%		
Surge Test	Surge voltage = $\sqrt{(6000 \times P \times R)}$ DC P is power rating, R is resistance value, surge voltage is not more than listed at right. Surge spec = 1.2/50µs Period = 12 sec Number of surges = 3000	SSR400	30 KV	5%
		SSR500	35 KV	

Quality • Reliability
Cost-Down via Technology

SWA

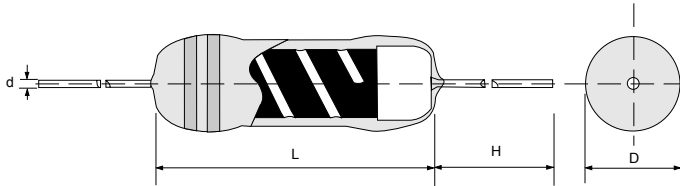

[*structure pending patent approval]

Specifications Per

• IEC 60115-1, 60115-4

Features

- Flameproof multi-layer coating meets UL 94 V-0
- Flameproof feature meets overload test UL 1412
- Enhanced weld spot is reliable against surge
- Special tin-plated electrolytic copper lead wire
- Products meet RoHS requirements and do not contain substances of very high concern identified by European Chemicals Agency
- SWA series is applied in high surge applications such as high rush current protection for power capacitor, motor start-up protection, car & motorcycle engine ignition, etc. to absorb harmful surge energy, so to prevent hazard of circuit damage caused by surge energy

■ DIMENSIONS

Type	Body Length (L, mm)	Body Diameter (D, mm)	Lead Wire Length (H, mm)	Lead Wire Diameter (d, mm)
SWA01	11.0 ± 1.0	4.5 ± 0.5	28 ± 3.0	0.7 ± 0.03
SWA02	13.5 ± 1.0	5.0 ± 0.5	30 ± 3.0	0.8 ± 0.03
SWA03	15.5 ± 1.0	5.5 ± 0.5	30 ± 3.0	0.8 ± 0.03

■ GENERAL SPECIFICATIONS

Type	Power Rating (at 70°C)	Maximum Working Voltage	Maximum Overload Voltage	Maximum Permissible Surge Voltage	Minimum Resistance	Maximum Resistance	Resistance Tolerance	Available Resistance Values
SWA01	1W	350V	600V	9KV	0.1 Ω	1.5KΩ	± 5%	E-24
SWA02	2W	350V	700V	10KV	0.1 Ω	1.5KΩ	± 5%	E-24
SWA03	3W	350V	700V	12KV	0.1 Ω	1.5KΩ	± 5%	E-24

Special sizes, values, and specifications not listed available on special order.

TAPING/PACKING SPECIFICATIONS

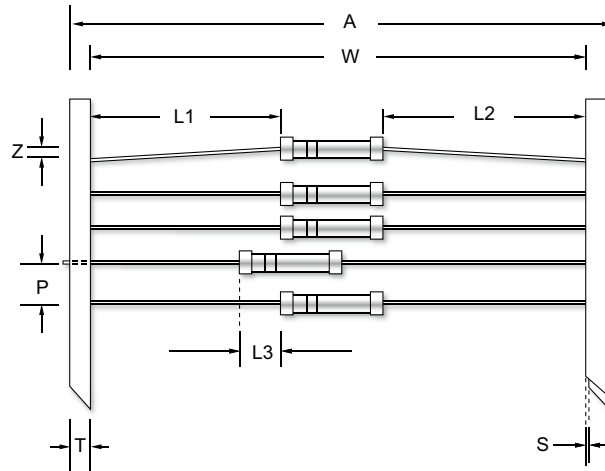

Unit (mm)

Type	A (Max.)	L1-L2 (Max.)	L3 (Max.)	P ±0.5	S (Max.)	T ±0.5	W ±1.5	Z (Max.)
SWA01	65	±1.0	0.5	5.0	0.8	6.0	52.5	1.2
SWA02	76	±1.5	1.0	10.0	0.8	6.0	63.5	1.2
SWA03	76	±1.5	1.0	10.0	0.8	6.0	63.5	1.2

TECHNICAL SPECIFICATIONS

Characteristics	Limits	
Dielectric Withstanding Voltage, VAC or DC	SWA01 / SWA02	600
	SWA03	1000
Temperature Coefficient, PPM / °C*	±100, ±300	
Operating Temperature Range, °C	-55~+200	
Insulation Resistance, MΩ	10 ⁴	

* Not applicable to all resistance values. Please check with us regarding the PPM of specific resistance value(s).

POWER DERATING CURVE

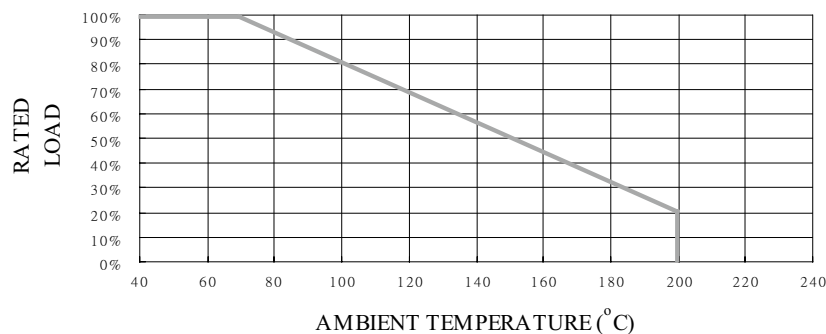

■ PART NUMBER

Example: SWA01J100RTKZTB1K0

SWA01	J	100R	TKZ	TB1K0
Type	Tolerance	Resistance	TCR	Packaging
	J (5%)	100Ω 4-character code containing - 3 significant digits 1 letter multiplier <u>MULTIPLIER</u> R = 1 K = 10 ³ M = 10 ⁶ G = 10 ⁹	3-character code TKZ = Default Product Temperature Coefficient. Information of typical product temperature coefficient can be found in the Technical Summary section of the datasheet.*	5-character code TB = Tape Box (pieces per box) SWA01 1K0 = 1,000 <u>SWA02/SWA03</u> 500 = 500

* For the availabilities of non-default temperature coefficient, please check with us. Reference for TCR letter codes can be found in section (4) of Part Number Construction in the Appendices.

■ PERFORMANCE SPECIFICATIONS

Characteristics	Test Conditions	Limits
Short Time Over Load	IEC 60115-1 4.13 5 seconds 2.5x rated voltage (not over max. overload voltage)	±2%
Load Life In Humidity	IEC 60115-1 4.24 56 days rated load at (40±2)°C and (93±3)% relative humidity	±5%
Load Life 1,000 hours	IEC 60115-1 4.25.1 Rated load with 1.5 hours ON, 0.5 hours OFF, at (70±2)°C	±5%
Resistance To Soldering Heat	IEC 60115-1 4.18.2 Leads immersed till 3mm from the body in (260±5)°C solder for 10±1 seconds	±1%
Solderability	IEC 60115-1 4.17.2 Solder area covered after (235±3)°C/(2±0.2) seconds with flux applied	90% Min.
Vibration	IEC 60115 4.22 Six hours in each parallel and axial direction with a simple harmonic motion having an amplitude of 0.75mm and 10 to 500 Hz.	±1%
Thermal Endurance	IEC 60115-1 4.25.3 1000 hours at 200°C without load	±1%
Thermal Shock	IEC 60115-1 4.19 -55°C 30minutes, +155°C 30minutes, 5 cycles	±3%
Surge Test	Surge voltage = $\sqrt{(12,000 PR)}$ DC P is power rating, R is resistance value, surge voltage is not more than listed at right. Surge spec = 1.2/50µs Period = 60 sec Number of surges = 100	SWA01 9KV SWA02 10KV SWA03 12KV 5%

SRM-201 withstands 51,840,000 surges at 30KV, in duration of 500 hours.



Firstohm®

第一電

Surge Resistor Pulse Resistor
High Voltage Resistor Surge MELF
Power MELF High Temperature Resistor
Dual Power Resistor Spark Gap Resistor
All General-Purpose Resistors

Phone: +886-2-27051878, 27051879, 27079869

Fax: +886-2-27036701

E-mail: QR@Firstohm.com.tw

<http://www.Firstohm.com.tw>

TÜV ISO 9002 ISO 14001 / IECQ CERTIFIED FACTORY

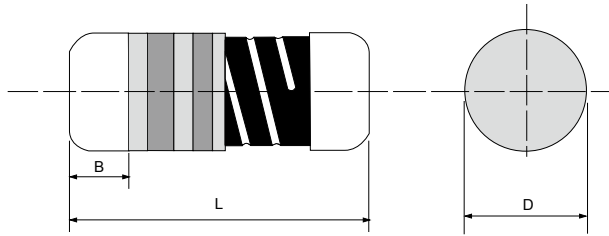

[*structure pending patent approval]

Specifications Per

- IEC 60115-1, 60115-4

Features

- SMD enabled structure
- Flameproof multi-layer coating meets UL 94 V-0
- Flameproof feature meets overload test UL 1412
- Enhanced weld spot is reliable against surge
- Products meet RoHS requirements and do not contain substances of very high concern identified by European Chemicals Agency
- SWM series is applied in high surge applications such as high rush current protection for power capacitor, motor start-up protection, car & motorcycle engine ignition, etc. to absorb harmful surge energy, so to prevent hazard of circuit damage caused by surge energy

■ DIMENSIONS

Type	Body Length (L, mm)	Body Diameter (D, mm)	Soldering Spot (B, mm)
SWM100	8.8 ± 1.0	3.0 ± 0.2	1.3 Min.
SWM200	10.8 ± 1.0	4.0 ± 0.5	1.6 Min.
SWM300	13.0 ± 1.5	4.6 ± 0.7	1.8 Min.
SWM400	15.0 ± 2.0	5.1 ± 1.0	2.0 Min.

■ GENERAL SPECIFICATIONS

Type	Power Rating (at 70°C)	Maximum Working Voltage	Maximum Overload Voltage	Maximum Permissible Surge Voltage	Minimum Resistance	Maximum Resistance	Resistance Tolerance	Available Resistance Values
SWM100	1W	350	700	7.5KV	0.1 Ω	1.5KΩ	± 5%	E-24
SWM200	2W	400	800	8.5KV	0.1 Ω	1.5KΩ	± 5%	E-24
SWM300	3W	400	800	9KV	0.1 Ω	1.5KΩ	± 5%	E-24
SWM400	4W	450	900	11KV	0.1 Ω	1.5KΩ	± 5%	E-24

Special sizes, values, and specifications not listed available on special order.

Quality • Reliability
Cost-Down via Technology

SWM

■ PART NUMBER

Example: SWM200J100RTKZBK2K0

SWM200	J	100R	TKZ	BK2K0
Type	Tolerance	Resistance	TCR	Packaging
	J (5%)	100Ω 4-character code containing - 3 significant digits 1 letter multiplier <u>MULTIPLIER</u> R = 1 K = 10 ³ M = 10 ⁶ G = 10 ⁹	3-character code TKZ = Default Product Temperature Coefficient. Information of typical product temperature coefficient can be found in the Technical Summary section of the datasheet.*	5-character code BK = Bulk SWM100/SWM200 SWM300/SWM400 BK + Quantity

* For the availabilities of non-default temperature coefficient, please check with us. Reference for TCR letter codes can be found in section (4) of Part Number Construction in the Appendices.

■ TECHNICAL SPECIFICATIONS

Characteristics	Limits	
Dielectric Withstanding Voltage, VAC or DC	SWM100 / SWM200 / SWM300	700
	SWM400	1000
Temperature Coefficient, PPM / °C*	±100, ±300	
Operating Temperature Range, °C	-55~+200	
Insulation Resistance, MΩ	10 ⁴	

* Not applicable to all resistance values. Please check with us regarding the PPM of specific resistance value(s).

■ POWER DERATING CURVE

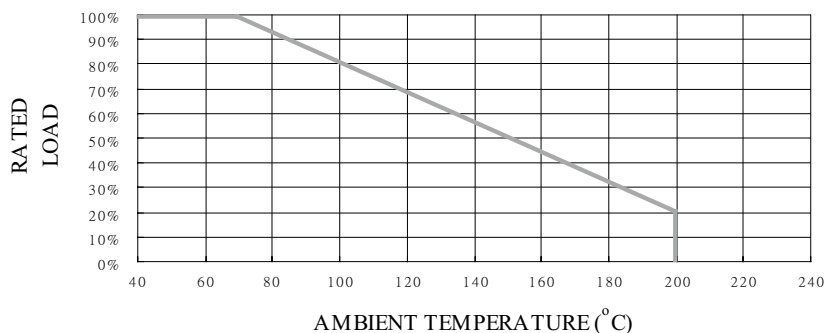

Quality • Reliability
Cost-Down via Technology

SWM

■ PERFORMANCE SPECIFICATIONS

Characteristics	Test Conditions	Limits		
Short Time Over Load	IEC 60115-1 4.13 5 seconds 2.5x rated voltage (not over max. overload voltage)	±2%		
Load Life In Humidity	IEC 60115-1 4.24 56 days rated load at (40±2)°C and (93±3)% relative humidity	±5%		
Load Life 1,000 hours	IEC 60115-1 4.25.1 Rated load with 1.5 hours ON, 0.5 hours OFF, at (70±2)°C	±5%		
Resistance To Soldering Heat	IEC 60115-1 4.18.2 Dip the resistor into a solder bath measured (260±5)°C and hold it for a 10±1 seconds	±1%		
Solderability	IEC 60115-1 4.17.2 Solder area covered after (230±3)°C/(2±0.2) seconds with flux applied	95% Min.		
Vibration	IEC 60115 4.22 Six hours in each parallel and axial direction with a simple harmonic motion having an amplitude of 0.75mm and 10 to 500 Hz.	±1%		
Thermal Endurance	IEC 60115-1 4.25.3 1000 hours at 200°C without load	±1%		
Thermal Shock	IEC 60115-1 4.19 -55°C 30minutes, +155°C 30minutes, 5 cycles	±3%		
Surge Test	Surge voltage = $\sqrt{(12,000 PR)}$ DC P is power rating, R is resistance value, surge voltage is not more than listed at right. Surge spec = 1.2/50µs Period = 60 sec Number of surges = 100	SWM01 SWM02 SWM03 SWM04	7.5KV 8.5KV 9KV 11KV	5%

Quality • Reliability
Cost-Down via Technology

SWM

■ SUGGESTED PAD LAYOUT

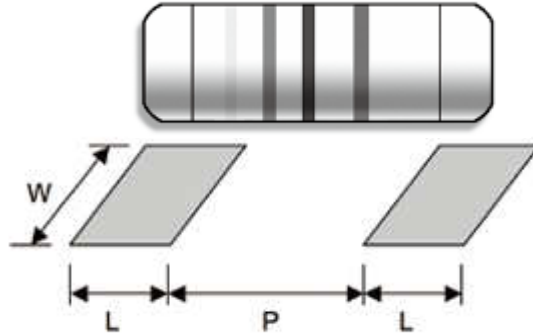

Type	Soldering Mode*	Pad Length (L, mm, Min.)	Pad Spacing (P, mm)	Pad Width (W, mm, Min.)
SWM100	Reflow (Not recommended)	3.0	4.9 ± 0.3	3.7
	Wave	3.5	4.8 ± 0.3	4.0
SWM200	Reflow (Not recommended)	4.0	6.2 ± 0.4	4.5
	Wave	4.5	6.0 ± 0.4	5.0
SWM300	Reflow (Not recommended)	4.5	8.0 ± 0.4	5.0
	Wave	5.0	7.7 ± 0.4	5.5
SWM400	Reflow (Not recommended)	5.0	9.3 ± 0.4	5.5
	Wave	5.0	9.0 ± 0.4	5.5

For better heat dissipation / lower heat resistance, increase W & L.
*Wave soldering is highly recommended for all SWM types.

■ COVER TAPE PEELING SPECIFICATION

Recommended peeling force:

SWM100, SWM200: 70±10gf

SWM300, SWM400: 80±10gf

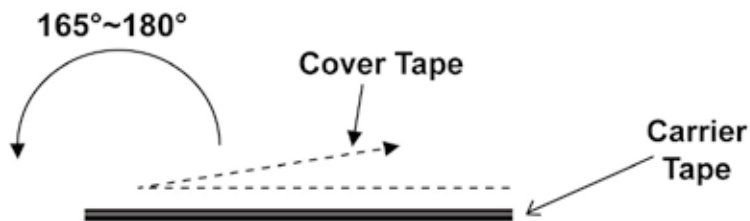

Quality • Reliability
Cost-Down via Technology

WA

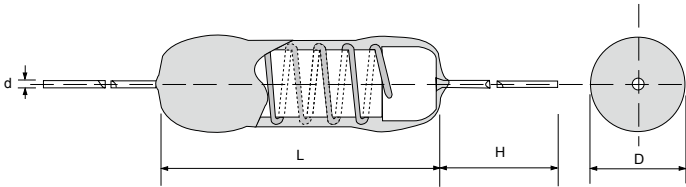

Specifications Per

• IEC 60115-1, IEC 60115-4

Features

- Flameproof multi-layer coating meets UL 94 V-0
- Flameproof feature meets overload test UL 1412
- Color code per MIL & EIA standards
- Special tin-plated electrolytic copper lead wire
- Products meet RoHS requirements and do not contain substances of very high concern identified by European Chemicals Agency

DIMENSIONS

Type	Body		Leadwire	
	Length (L, mm)	Diameter (D, mm)	Length (H, mm)	Diameter (d, mm)
WA01S	8.80 ± 1.0	3.2 ± 0.2	28 ± 3.0	0.6 ± 0.03
WA02S	11.0 ± 1.0	4.0 ± 0.5	28 ± 3.0	0.7 ± 0.03
WA03S	13.5 ± 1.0	5.0 ± 0.5	30 ± 3.0	0.8 ± 0.03
WA04S	15.5 ± 1.0	5.5 ± 0.5	30 ± 3.0	0.8 ± 0.03
WA05S / WA06S	19.0 ± 1.0	6.0 ± 0.5	30 ± 3.0	0.8 ± 0.03

GENERAL SPECIFICATIONS

Type	Power Rating (at 70°C)	Maximum Working Voltage	Maximum Overload Voltage	Minimum Resistance	Maximum Resistance	Resistance Tolerance	Available Resistance Values
WA01S	1W	350V	600V	0.1Ω	390Ω	± 2%, ±5%	E-24
WA02S	2W	350V	700V	0.1Ω	449Ω	± 2%, ±5%	E-24
WA03S	3W	350V	700V	0.1Ω	549Ω	± 2%, ±5%	E-24
WA04S	4W	350V	700V	0.1Ω	1KΩ	± 2%, ±5%	E-24
WA05S WA06S	5W / 6W	450V	800V	0.1Ω	1K5Ω	± 2%, ±5%	E-24

Special sizes, values, and specifications not listed available on special order.

PART NUMBER

Example: WA03SJ100RTKZTB500

WA03S	J	100R	TKZ	TB500
Type	Tolerance	Resistance	TCR	Packaging
	G (2%) J (5%)	100Ω 4-character code containing - 3 significant digits 1 letter multiplier <u>MULTIPLIER</u> R = 1 K = 10 ³ M = 10 ⁶ G = 10 ⁹	3-character code TKZ = Default Product Temperature Coefficient. Information of typical product temperature coefficient can be found in the Technical Summary section of the datasheet.*	5-character code TB = Tape Box (pieces per box) WA01S 2K0 = 2,000 WA02S 1K0 = 1,000 <u>WA03S/WA04S</u> <u>WA05S/WA06S</u> 500 = 500

* For the availabilities of non-default temperature coefficient, please check with us. Reference for TCR letter codes can be found in section (4) of Part Number Construction in the Appendices.

POWER DERATING CURVE

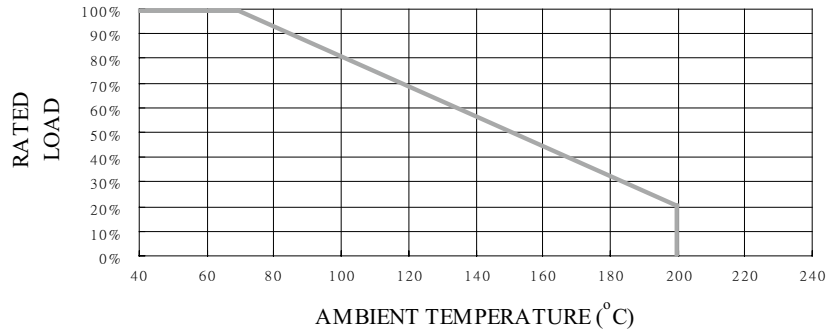

TECHNICAL SUMMARY

Characteristics	Limits	
Dielectric Withstanding Voltage, VAC or DC	1W 2 to 3W 4 to 6W	350 600 1000
Temperature Coefficient, PPM / °C*	Typically ±300	
Operating Temperature Range, °C	-55~+200	
Insulation Resistance, MΩ	10 ⁴	

* Not applicable to all resistance values. Please check with us regarding the PPM of specific resistance value(s).

PERFORMANCE SPECIFICATIONS

Characteristics	Test Conditions	Limits
Short Time Over Load	IEC 60115-1 4.13 5 seconds 2.5x rated voltage (not over max. overload voltage)	±1%
Load Life In Humidity	IEC 60115-1 4.24 56 days rated load at (40±2)°C and (93±3)% relative humidity	±5%
Load Life 1,000 hours	IEC 60115-1 4.25.1 Rated load with 1.5 hours ON, 0.5 hours OFF, at (70±2)°C	±5%
Resistance To Soldering Heat	IEC 60115-1 4.18.2 Leads immersed till 3mm from the body in (260±5)°C solder for 10±1 seconds	±1%
Solderability	IEC 60115-1 4.17.2 Solder area covered after (235±3)°C/(2±0.2) seconds with flux applied	90% Min.
Vibration	IEC 60115-1 4.22 Six hours in each parallel and axial direction with a simple harmonic motion having an amplitude of 0.75mm and 10 to 500 Hz.	±1%
Thermal Endurance	IEC 60115-1 4.25.3 1000 hours at 200°C without load	±1%
Thermal Shock	IEC 60115-1 4.19 -55°C 30minutes, +155°C 30minutes, 5 cycles	±2%

Quality • Reliability
Cost-Down via Technology

WA

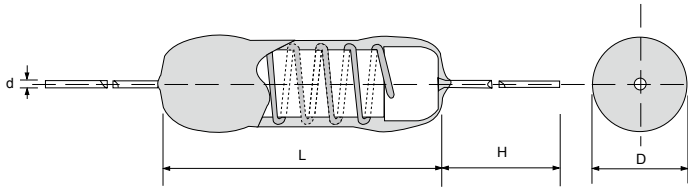

Specifications Per

• IEC 60115-1, IEC 60115-4

Features

- Flameproof multi-layer coating meets UL 94 V-0
- Flameproof feature meets overload test UL 1412
- Color code per MIL & EIA standards
- Special tin-plated electrolytic copper lead wire
- Products meet RoHS requirements and do not contain substances of very high concern identified by European Chemicals Agency

DIMENSIONS

Type	Body		Leadwire	
	Length (L, mm)	Diameter (D, mm)	Length (H, mm)	Diameter (d, mm)
WA051	8.80 ± 1.0	3.2 ± 0.2	28 ± 3.0	0.6 ± 0.03
WA01	11.0 ± 1.0	4.0 ± 0.5	28 ± 3.0	0.7 ± 0.03
WA02	13.5 ± 1.0	5.0 ± 0.5	30 ± 3.0	0.8 ± 0.03
WA03	15.5 ± 1.0	5.5 ± 0.5	30 ± 3.0	0.8 ± 0.03
WA04/WA05	19.0 ± 1.0	6.0 ± 0.5	30 ± 3.0	0.8 ± 0.03
WA06	24.0 ± 1.0	8.0 ± 0.5	30 ± 3.0	0.8 ± 0.03
WA07/WA08	31.5 ± 1.0	8.0 ± 0.5	30 ± 3.0	0.8 ± 0.03

GENERAL SPECIFICATIONS

Type	Power Rating (at 70°C)	Maximum Working Voltage	Maximum Overload Voltage	Minimum Resistance	Maximum Resistance	Resistance Tolerance
WA051	1/2W	350V	600V	0.1Ω	390Ω	±2%, ±5%
WA01	1W	350V	600V	0.1Ω	449Ω	±2%, ±5%
WA02	2W	350V	700V	0.1Ω	549Ω	±2%, ±5%
WA03	3W	350V	700V	0.1Ω	1KΩ	±2%, ±5%
WA04/WA05	4W / 5W	450V	800V	0.1Ω	1K5Ω	±2%, ±5%
WA06	6W	500V	1000V	0.1Ω	3K3Ω	±2%, ±5%
WA07/WA08	7W / 8W	600V	1200V	0.1Ω	3K3Ω	±2%, ±5%

Special sizes, values, and specifications not listed available on special order.

■ TAPING/PACKING SPECIFICATIONS

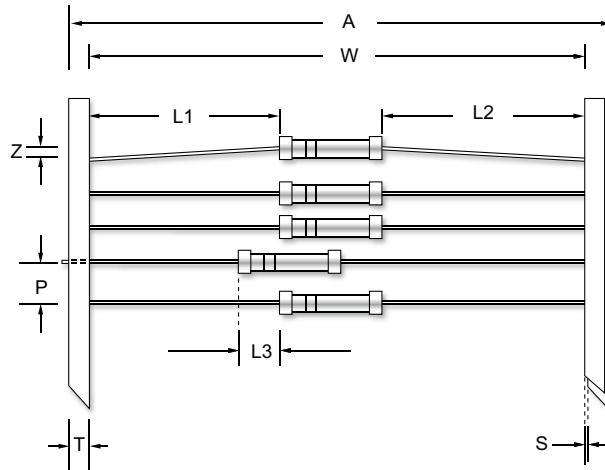

Unit (mm)

Type	A Max.	L1-L2 (Max.)	L3 (Max.)	P ±0.5	S (Max.)	T ±0.5	W ±1.5	Z (Max.)
WA051	65	±1.0	0.5	5.0	0.8	6.0	52.5	1.2
WA01	65	±1.0	0.5	5.0	0.8	6.0	52.5	1.2
WA02	76	±1.5	1.0	10.0	0.8	6.0	63.5	1.2
WA03	76	±1.5	1.0	10.0	0.8	6.0	63.5	1.2
WA04/WA05	76	±1.5	1.0	10.0	0.8	6.0	63.5	1.2
WA06	76	±1.5	1.0	10.0	0.8	6.0	63.5	1.2
WA07/WA08	97	±1.5	1.0	10.0	0.8	6.0	83.0	1.2

■ TECHNICAL SPECIFICATIONS

Characteristics	Limits	
Dielectric Withstanding Voltage, VAC or DC	1/ 2W 1W to 2W 3W to 8W	350 600 1000
Temperature Coefficient 1/2W to 8W, PPM / °C*	±100, ±300	
Operating Temperature Range, °C	-55~+200	
Insulation Resistance, MΩ	10 ⁴	

* Not applicable to all resistance values. Please check with us regarding the PPM of specific resistance value(s).

Quality • Reliability
Cost-Down via Technology

WA

POWER DERATING CURVE

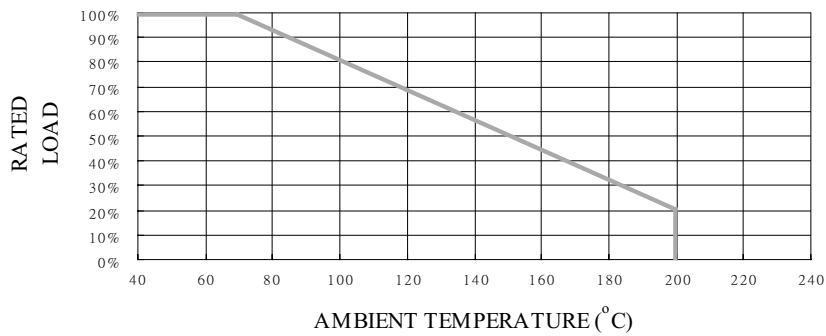

PART NUMBER

Example: WA051J100RTKZTB2K0

WA051	J	100R	TKZ	TB2K0
Type	Tolerance	Resistance	TCR	Packaging
	G (2%) J (5%)	100Ω 4-character code containing - 3 significant digits 1 letter multiplier <u>MULTIPLIER</u> R = 1 K = 10 ³ M = 10 ⁶ G = 10 ⁹	3-character code TKZ = Default Product Temperature Coefficient. Information of typical product temperature coefficient can be found in the Technical Summary section of the datasheet.*	5-character code TB = Tape Box (pieces per box) <u>WA051</u> 2K0 = 2,000 <u>WA01</u> 1K0 = 1,000 <u>WA02/WA03/</u> <u>WA04/WA05</u> 500 = 500 <u>WA06/WA07</u> WA08 250 = 250

* For the availabilities of non-default temperature coefficient, please check with us. Reference for TCR letter codes can be found in section (4) of Part Number Construction in the Appendices.

■ PERFORMANCE SPECIFICATIONS

Characteristics	Test Conditions	Limits
Short Time Over Load	IEC 60115-1 4.13 5 seconds 2.5x rated voltage (not over max. overload voltage)	±1%
Load Life In Humidity	IEC 60115-1 4.24 56 days rated load at (40±2)°C and (93±3)% relative humidity	±5%
Load Life 1,000 hours	IEC 60115-1 4.25.1 Rated load with 1.5 hours ON, 0.5 hours OFF, at (70±2)°C	±5%
Resistance To Soldering Heat	IEC 60115-1 4.18.2 Leads immersed till 3mm from the body in (260±5)°C solder for 10±1 seconds	±1%
Solderability	IEC 60115-1 4.17.2 Solder area covered after (235±3)°C/(2±0.2) seconds with flux applied	90% Min.
Vibration	IEC 60115 4.22 Six hours in each parallel and axial direction with a simple harmonic motion having an amplitude of 0.75mm and 10 to 500 Hz.	±1%
Thermal Endurance	IEC 60115-1 4.25.3 1000 hours at 200°C without load	±1%
Thermal Shock	IEC 60115-1 4.19 -55°C 30minutes, +155°C 30minutes, 5 cycles	±2%

ZMM - Zero Ohm Metal Film MELF Resistor

Quality • Reliability
Cost-Down via Technology

ZMM

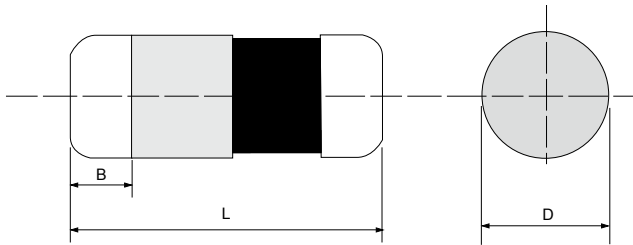

Specifications Per

- IEC 60115-1, IEC 60115-2

Features

- SMD enable structure
- Excellent solderability termination
- Stable metal film construction
- Products meet RoHS requirements and do not contain substances of very high concern identified by European Chemicals Agency

■ DIMENSIONS

Type	Body Length (L, mm)	Body Diameter (D, mm)	Soldering Spot (B, mm)	Net Weight Per 1000 pcs
ZMM204	3.52 ± 0.08	1.35 ± 0.1	0.6 Min.	17 grams
ZMM207	5.90 ± 0.20	2.20 ± 0.1	1.0 Min.	66 grams

■ GENERAL SPECIFICATIONS

Type	Maximum Resistance	Maximum Current
ZMM204	20mΩ	2A
ZMM207	20mΩ	4A

Special value available on request.

■ TECHNICAL SPECIFICATIONS

Characteristics	Limits	
	ZMM204	ZMM207
Insulation Voltage (1min)	>500V AC	>700V AC
Insulation Resistance	>10 ¹¹ Ω	>10 ¹¹ Ω
Operating Temperature	-55 ~ +125°C	-55 ~ +125°C
Failure Rate	<1pcs out of 10 ⁹ device hours	<1pcs out of 10 ⁹ device hours

ZMM - Zero Ohm Metal Film MELF Resistor

Quality • Reliability
Cost-Down via Technology

ZMM

■ PART NUMBER

Example: ZMM204X000RXXXTR3K0

ZMM204	X	000R	XXX	TR3K0
Type	Tolerance Parameter Not Applicable	Resistance* 0Ω 4-character code	TCR 3-character code Parameter Not Applicable	Packaging 5-character code TR = Tape Reel (pieces per reel) ZMM204 3K0 = 3,000 6K0 = 6,000** 10K = 10,000** ZMM207 2K0 = 2,000 6K0 = 6,000** 10K = 10,000**

* Please refer to the General Specifications section of ZMM datasheet for information on maximum resistance value. **upon request

■ SUGGESTED PAD LAYOUT

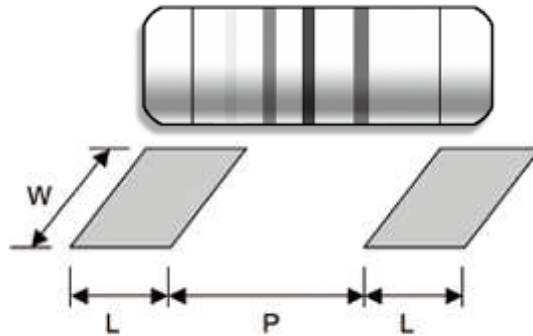

Type	Soldering Mode	Pad Length (L, mm, Min.)	Pad Spacing (P, mm)	Pad Width (W, mm, Min.)
ZMM204	Reflow	1.0	2.0 ± 0.2	1.6
	Wave	1.2	2.0 ± 0.2	1.6
ZMM207	Reflow	2.0	3.0 ± 0.3	3.0
	Wave	2.5	3.0 ± 0.3	3.0

For better heat dissipation / lower heat resistance, increase W & L.

■ COVER TAPE PEELING SPECIFICATION

Recommended peeling force:

ZMM204, ZMM207: 50±5gf

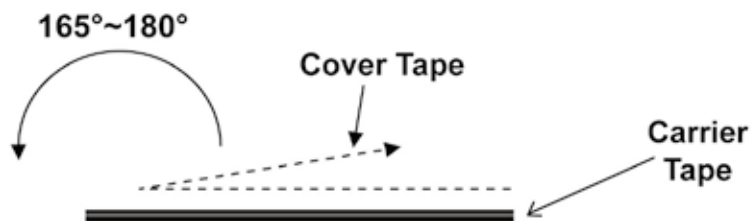

ZOM Zero Ohm Metal Film Resistor

Quality • Reliability
Cost-Down via Technology

ZOM

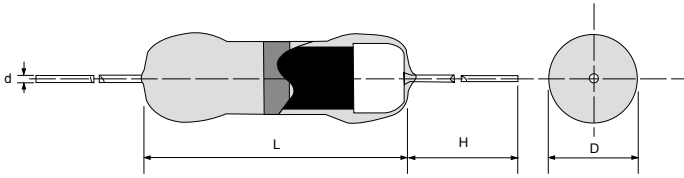

Features

- Conformal multi-layer coating against humidity
- Very low resistance
- Stable metal film construction
- Special tin-plated deoxygenized copper wire for resistance stabilization during operation
- Products meet RoHS requirements and do not contain substances of very high concern identified by European Chemicals Agency

DIMENSIONS

Type	Body Length (L, mm)	Body Diameter (D, mm)	Lead Wire Length (H, mm)	Lead Wire Diameter (d, mm)	Net Weight Per 1000Pcs
ZOM204	3.2 ± 1.0	1.8 ± 0.2	28 ± 1.0	0.5 ± 0.03	145 Grams
ZOM207	6.5 ± 0.7	2.4 ± 0.2	26 ± 1.0	0.6 ± 0.03	220 Grams

GENERAL SPECIFICATIONS

Type	Maximum Resistance	Maximum Current
ZOM204	10mΩ	3A
ZOM207	10mΩ	5A

Special sizes, values, and specifications not listed available on special order.

TECHNICAL SPECIFICATIONS

Characteristics	Limits	
	ZOM204	ZOM207
Insulation Voltage (1min)	>500V AC	>700V AC
Insulation Resistance	>10 ¹¹ Ω	>10 ¹¹ Ω
Operating Temperature	-55 ~ +155 °C	-55 ~ +155 °C
Terminal Strength	>30N	>50N
Failure Rate	<10pcs out of 10 ⁹ device hours	<10pcs out of 10 ⁹ device hours

Quality • Reliability
Cost-Down via Technology

■ TAPING/PACKING SPECIFICATIONS

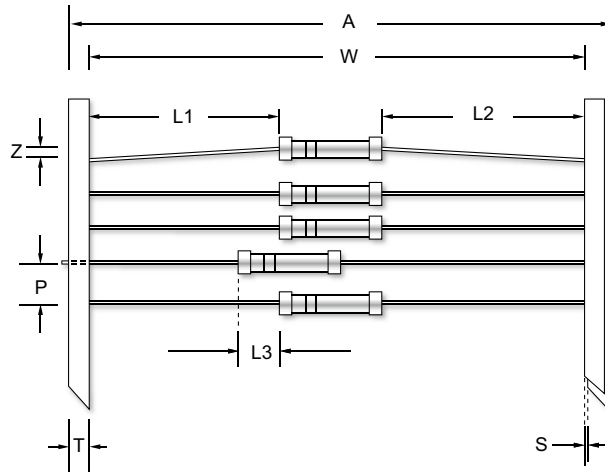

Unit (mm)

Type	A Max.	L1-L2 (Max.)	L3 (Max.)	P ±0.5	S (Max.)	T ±0.5	W ±1.5	Z (Max.)
ZOM204	65	±1.0	0.5	5.0	0.8	6.0	52.5	1.2
ZOM207	65	±1.0	0.5	5.0	0.8	6.0	52.5	1.2

Type No.	Packing Type	ZOM204	ZOM207
Minimum Packing QTY (pcs)	Ammo pack	5000	5000

■ PART NUMBER

Example: ZOM207X000RXXXTB5K0

ZOM207	X	000R	XXX	TB5K0
Type	Tolerance	Resistance*	TCR	Packaging
	Parameter Not Applicable	0Ω 4-character code	3-character code Parameter Not Applicable	5-character code TB = Tape Box (pieces per box) ZOM204/ZOM207 5K0 = 5,000

* Please refer to the General Specifications section of ZOM datasheet for information on maximum resistance value.

Firstohm®



Appendices

Resistance Values to IEC-Standard

Quality • Reliability
Cost-Down via Technology

E12 10%	E24 5%	E48 2%	E96 1%	E192 ≤0.5%	E12 10%	E24 5%	E48 2%	E96 1%	E192 0.5%	E12 10%	E24 5%	E48 2%	E96 1%	E192 ≤0.5%
100	100	100	100	100	220	220			218					481
				101				221	221			487	487	487
			102	102					223					493
				104			226	226	226				499	499
		105	105	105					229					505
				106				232	232		510	511	511	511
			107	107					234					517
				109			237	237	237				523	523
	110	110	110	110		240			240					530
				111				243	243			536	536	536
			113	113					246					542
				114			249	249	249				549	549
		115	115	115					252					556
				117				255	255	560	560	562	562	562
			118	118					258					569
120	120		120	120			261	261	261				576	576
		121	121	121					264					583
				123				267	267			590	590	590
			124	124	270	270			271					597
				126			274	274	274				604	604
		127	127	127					277					612
				129				280	280		620	619	619	619
	130		130	130					284					626
				132			287	287	287				634	634
		133	133	133					291					642
				135				294	294			649	649	649
			137	137					298					657
				138		300	301	301	301				665	665
		140	140	140					305					673
				142				309	309	680	680	681	681	681
				143					312					690
				145			316	316	316				698	698
		147	147	147					320					706
				149				324	324			715	715	715
150	150		150	150					328					723
				152	330	330	332	332	332				732	732
		154	154	154					336					741
				156				340	340		750	750	750	750
			158	158					344					759
	160		160	160			348	348	348				768	768
		162	162	162					352					777
				164				357	357			787	787	787
			165	165		360			361					796
				167			365	365	365				806	806
		169	169	169					370	820	820			816
				172				374	374			825	825	825
				174					379					835
				176			383	383	383				845	845
		178	178	178					388					856
180	180		180	180	390	390		392	392			866	866	866
			182	182					397					876
				184			402	402	402				887	887
		187	187	187					407					898
				189				412	412		910	909	909	909
			191	191					417					920
				193			422	422	422				931	931
		196	196	196		430			427					942
				198				432	432			953	953	953
			200	200					437					965
	200			203			442	442	442				976	976
		205	205	205					448					988
				208				453	453					
			210	210					459					
			210	210			464	464	464					
				213	470	470			470					
		215	215	215				475	475					

Quality • Reliability
Cost-Down via Technology

SMD RESISTOR SOLDERING PROFILE FOR LEAD-FREE TERMINATION

REFLOW SOLDERING

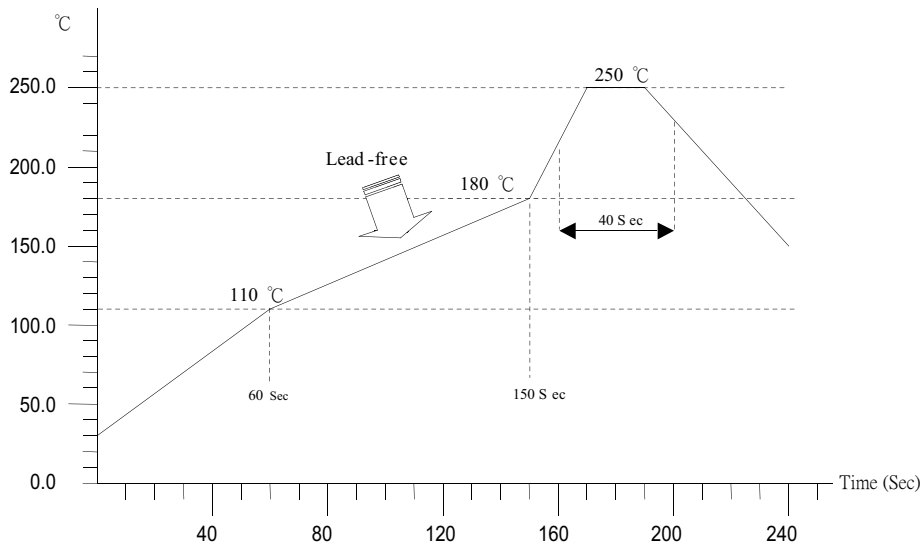

RECOMMENDATIONS

PRE-HEATING	OVER 120 SEC
RAMP-UP (WETTING)	2~4°C / SEC
RAMP-DOWN (COOLING)	-1~-3°C / SEC

WAVE SOLDERING

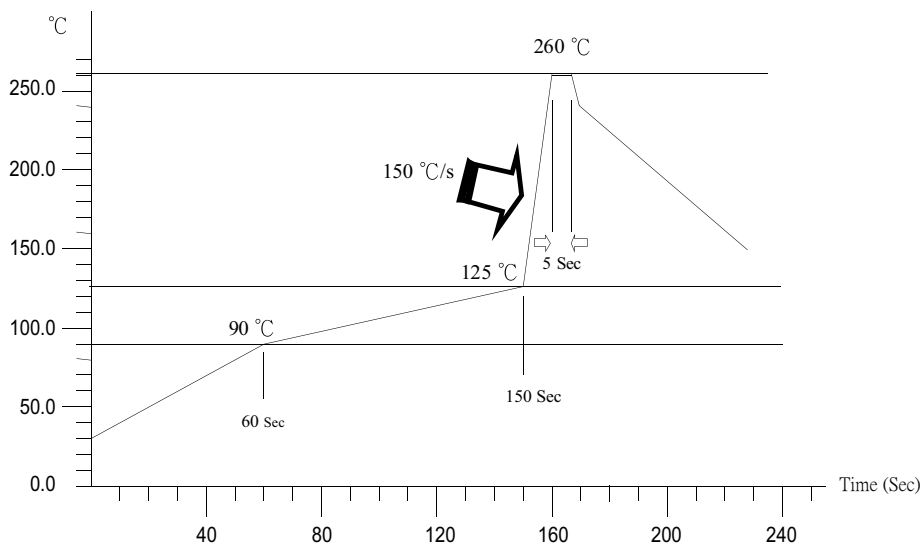

RECOMMENDATIONS

PRE-HEATING	OVER 120 SEC
RAMP-UP (WETTING)	150°C / SEC
RAMP-DOWN (COOLING)	-1~-3°C / SEC
TIME IN WAVE	5 SEC

Quality • Reliability
Cost-Down via Technology

■ PART NUMBER CONSTRUCTION FOR M, MM, MM(P), MMP, MP, PMA, SFP AND SM SERIES:

Example: MM204F162R TKR TR3K0

MM204	F	162R	TKR	TR3K0
MM204	1%	162Ω	50ppm	Tape Reel 3,000 pieces per reel
Type	Tolerance*	Resistance	TCR	Packaging**
Type name seen in the datasheet	B (0.1%) C (0.25%) D (0.5%) F (1%) G (2%) J (5%)	4-character code containing - 3 significant digits 1 letter multiplier <u>MULTIPLIER</u> R = 1 K = 10 ³ M = 10 ⁶ G = 10 ⁹	3-character code Insert the corresponding code for the temperature coefficient available for the specific product. Please see the TCR letter code table below in section (4)*.	5-character code TB = Tape Box TR = Tape Reel BK = Bulk*** 500 = 500 1K0 = 1,000 2K0 = 2,000 2K5 = 2,500 3K0 = 3,000 5K0 = 5,000 6K0 = 6,000 10K = 10,000

* May not be applicable to all product types or to all resistance values. Please check with us before placing order.

** Actual packaging varies by types. Please refer to the individual datasheet or check with us.

*** Quantities for bulk packaging vary by types. Please check with us.

■ PART NUMBER CONSTRUCTION FOR ALL OTHER SERIES:

Example: EFP101J1K00TKZTR2K0

EFP101	J	1K00	TKZ	TR2K0
EFP101	5%	1kΩ	Typical product temperature coefficient	Tape Reel 2,000 pieces per reel
Type	Tolerance*	Resistance	TCR	Packaging**
Type name seen in the datasheet	D (0.5%) F (1%) G (2%) J (5%) K (10%) M (20%)	4-character code containing - 3 significant digits 1 letter multiplier <u>MULTIPLIER</u> R = 1 K = 10 ³ M = 10 ⁶ G = 10 ⁹	3-character code TKZ = Default Product Temperature Coefficient. Information of typical product temperature coefficient can be found in the technical summary of individual product datasheets. For availabilities of non-default temperature coefficient, please check with us. For reference on code letters, please see the TCR letter code table below in section (4)*.	5-character code TB = Tape Box TR = Tape Reel BK = Bulk*** 100 = 100 150 = 150 400 = 400 500 = 500 1K0 = 1,000 2K0 = 2,000 2K5 = 2,500 3K0 = 3,000 5K0 = 5,000 6K0 = 6,000 10K = 10,000

* May not be applicable to all product types or to all resistance values. Please check with us before placing order.

** Actual packaging varies by types. Please refer to the individual datasheets or check with us.

*** Quantities for bulk packaging vary by types. Please check with us.

■ EXAMPLES OF RESISTANCE VALUE CODE MARKING

4-character code containing 3 significant digits and 1 letter multiplier

Resistance	Value	Code	Resistance	Value	Code
0.1	Ω	R100	10	KΩ	10K0
0.365	Ω	R365	36.5	KΩ	36K5
0.68	Ω	R680	68	KΩ	68K0
0.909	Ω	R909	90.9	KΩ	90K9
1	Ω	1R00	100	KΩ	100K
3.65	Ω	3R65	365	KΩ	365K
6.8	Ω	6R80	680	KΩ	680K
9.09	Ω	9R09	909	KΩ	909K
10	Ω	10R0	1	MΩ	1M00
36.5	Ω	36R5	3.65	MΩ	3M65
68	Ω	68R0	6.8	MΩ	6M80
90.9	Ω	90R9	9.09	MΩ	9M09
100	Ω	100R	10	MΩ	10M0
365	Ω	365R	36.5	MΩ	36M5
680	Ω	680R	68	MΩ	68M0
909	Ω	909R	90.9	MΩ	90M9
1	KΩ	1K00	100	MΩ	100M
3.65	KΩ	3K65	365	MΩ	365M
6.8	KΩ	6K80	680	MΩ	680M
9.09	KΩ	9K09	909	MΩ	909M
			1	GΩ	1G00

■ LETTER CODE FOR TEMPERATURE COEFFICIENT OF RESISTANCE (TCR)

TCR 10 ⁻⁶ /K		Code Letter
*	TK	Z
±2500	TK	Y
±1500	TK	X
±1000	TK	W
±900	TK	9
±800	TK	8
±700	TK	7
±600	TK	6
±500	TK	V
±400	TK	4
±300	TK	3
±250	TK	U
±200	TK	2
±150	TK	T
±100	TK	S
±50	TK	R
±25	TK	Q
±15	TK	P
±10	TK	N
±5	TK	M

* Refer to the technical summary in the individual datasheets for product temperature coefficient.

*Quality • Reliability
Cost-Down via Technology*

*Quality • Reliability
Cost-Down via Technology*

*Quality • Reliability
Cost-Down via Technology*

Global Reach

