

Series: [QSS](#) / [QTS](#) 0,635mm High Speed Socket / Terminal Strips

QSS Series – Socket, Vertical Orientation

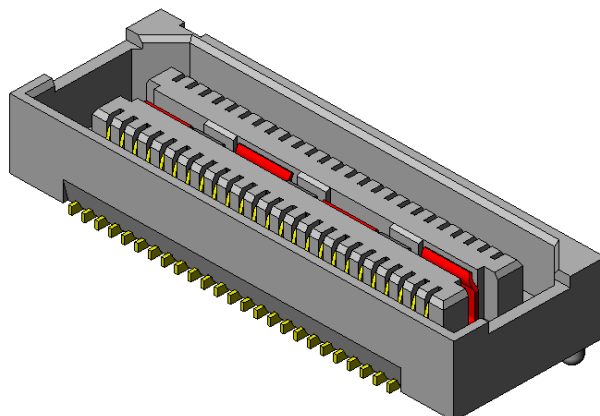

QTS Series – Terminal, Vertical Orientation

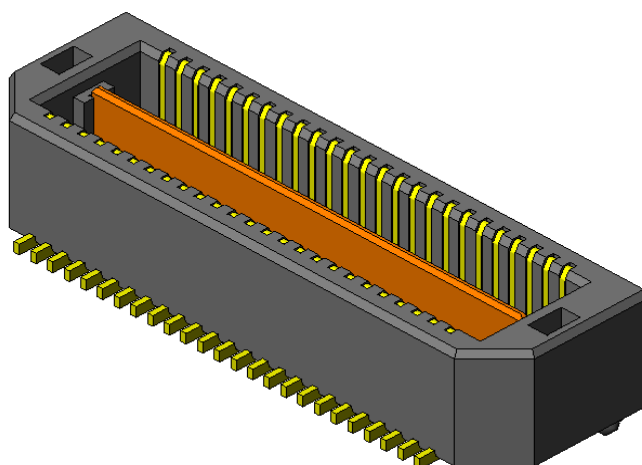

Other configurations available for:

Co-planar and perpendicular board-to-board applications

Rugged features / end options

Packaging options

See www.samtec.com for more information.

Series: **QSS / QTS** 0,635mm High Speed Socket / Terminal Strips

1.0 SCOPE

1.1 This specification covers performance, testing and quality requirements for Samtec QSS/QTS Series 0,635 mm High Speed Socket/Terminal Strips. These socket and terminal strips are available in vertical, edge mount and right angle configurations for parallel, perpendicular and co-planar board-to-board applications. All information contained in this specification is for a 5,00 mm mated height vertical configuration unless otherwise noted.

2.0 DETAILED INFORMATION

2.1 Product prints, footprints, catalog pages, test reports and other specific, detailed information can be found at www.samtec.com?QSS and www.samtec.com?QTS.

3.0 TESTING

3.1 **Current Rating:** 1.3A

3.2 **Voltage Rating:** 275 VAC

3.3 **Operating Temperature Range:** -55°C to +125°C

3.4 **Electrical:**

ITEM	TEST CONDITION	REQUIREMENT	STATUS
Withstanding Voltage	EIA-364-20 (No Flashover, Sparkover, or Breakdown)	825 VAC	Pass
Insulation Resistance	EIA-364-21 (5000 MΩ minimum)	15,000 MΩ	Pass
Contact Resistance (LLCR)	EIA-364-23	Δ 15 mΩ maximum (Samtec defined)/ No damage	Pass

3.5 **Mechanical:**

ITEM	TEST CONDITION	REQUIREMENT	STATUS
Durability	EIA-364-09C	100 cycles (w/Env.) 1000 cycles (w/o Env)	Pass
Random Vibration	EIA-364-28 Condition V, Letter B 7.56 G 'RMS', 50 to 2000 Hz, 2 hours per axis, 3 axis total, PSD 0.04	Visual Inspection: No Damage LLCR: Δ 15 mΩ maximum Event Detection: No interruption > 1.0 microsecond	Pass
Mechanical Shock	EIA-364-27 100 G, 6 milliseconds, sawtooth wave, 11.3 fps, 3 shocks/direction, 3 axis (18 total shocks)	Visual Inspection: No Damage LLCR: Δ 15 mΩ maximum Event Detection: No interruption > 1.0 microsecond	Pass
Normal Force	EIA-364-04	30 grams minimum for gold interface	Pass

Series: QSS / QTS 0,635mm High Speed Socket / Terminal Strips

3.6 Environmental:

ITEM	TEST CONDITION	REQUIREMENT	STATUS
Thermal Shock	EIA-364-32 Thermal Cycles: 100 (30 minute dwell) Hot Temp: +85°C Cold Temp: -55°C Hot/Cold Transition: Immediate	Visual Inspection: No Damage LLCR: Δ 15 m Ω DWV: 825 VAC IR: >15,000 M Ω	Pass
Thermal Aging (Temp Life)	EIA-364-17 Test Condition 4 @ 105°C Condition B for 250 hours	Visual Inspection: No Damage LLCR: Δ 15 m Ω DWV: 825 VAC IR: >15,000 M Ω	Pass
Cyclic Humidity	EIA-364-31 Test Temp: +25°C to +65°C Relative Humidity: 90 to 95% Test Duration: 240 hours	Visual Inspection: No Damage LLCR: Δ 15 m Ω DWV: 825 VAC IR: >15,000 M Ω	Pass
Gas Tight	EIA-364-36 Gas Exposure: Nitric Acid Vapor Duration: 60 min. Drying Temp.: 50°C +/- 3°C Measurements: Within 1 hour of Exposure	LLCR: Δ 15 m Ω	Pass

Series: QSS / QTS 0,635mm High Speed Socket / Terminal Strips

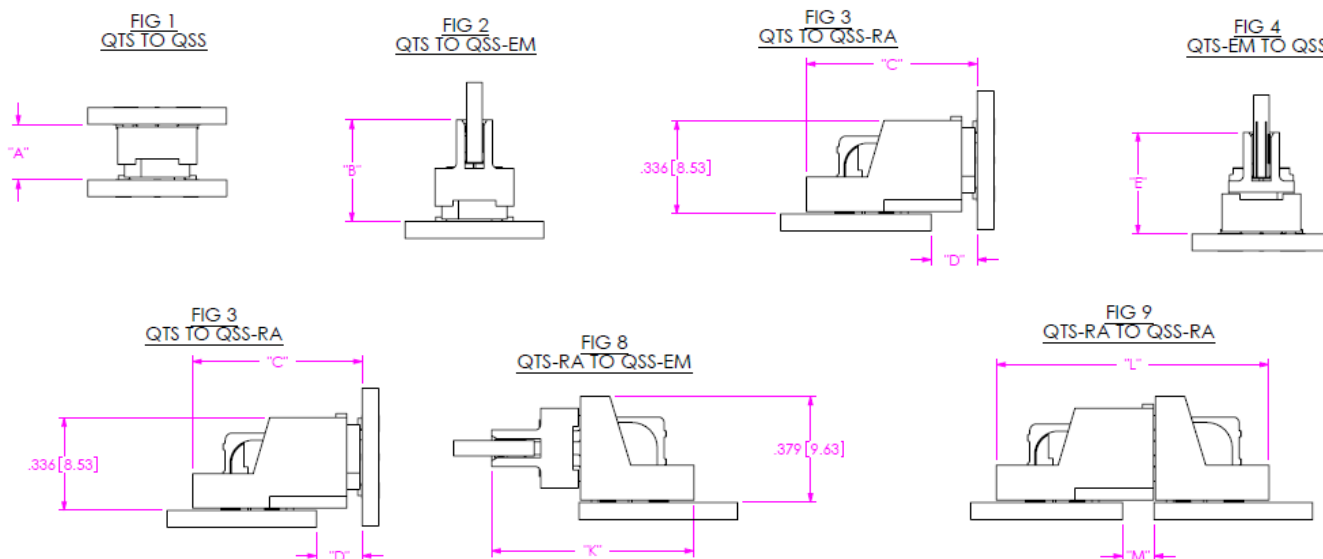
4.0 MATED SYSTEM
4.1 Orientations

4.2 Dimensions

	QSS				QSS-EM		QSS-RA				WIPE DISTANCE	
	FULLY MATED	MAX	FULLY MATED	MAX	FULLY MATED	MAX	FULLY MATED	MAX	FULLY MATED	MAX	FULLY MATED	MIN
QTS	"A" (FIG 1)				"B" (FIG 2)		"C" (FIG 3)		"D" (FIG 3)			
-01	.197 [5.00]	.204 [5.18]			.366 [9.30]	.373 [9.47]	.616 [15.65]	.623 [15.82]	.071 [1.80]	.078 [1.98]	.022 [0.56]	.015 [0.38]
-02	.315 [8.00]	.322 [8.18]			.484 [12.29]	.491 [12.47]	.734 [18.64]	.741 [18.82]	.189 [4.80]	.196 [4.98]	.022 [0.56]	.015 [0.38]
-03	.433 [11.00]	.440 [11.18]			.602 [15.29]	.609 [15.47]	.852 [21.64]	.859 [21.82]	.307 [7.80]	.314 [7.98]	.022 [0.56]	.015 [0.38]
-04	.630 [16.00]	.637 [16.18]			.798 [20.27]	.805 [20.45]	1.048 [26.62]	1.055 [26.80]	.503 [12.78]	.510 [12.95]	.022 [0.56]	.015 [0.38]
-05	.748 [19.00]	.755 [19.18]			.916 [23.27]	.923 [23.44]	1.166 [29.62]	1.173 [29.79]	.621 [15.77]	.628 [15.95]	.022 [0.56]	.015 [0.38]
-06	.866 [22.00]	.873 [22.17]			1.034 [26.26]	1.041 [26.44]	1.284 [32.61]	1.291 [32.79]	.739 [18.77]	.746 [18.95]	.022 [0.56]	.015 [0.38]
	"E" (FIG 4)				"F" (FIG 5)		"G" (FIG 6)					
-EM	.366 [9.30]	.373 [9.47]			.532 [13.51]	.539 [13.69]	.782 [19.86]	.789 [20.04]			.022 [0.56]	.015 [0.38]
	"H" (FIG 7)				"J" (FIG 7)		"K" (FIG 8)		"L" (FIG 9)		"M" (FIG 9)	
-RA	.556 [14.12]	.563 [14.30]	.145 [3.68]	.152 [3.86]	.722 [18.34]	.729 [18.52]	.972 [24.69]	.979 [24.87]	.016 [0.41]	.023 [0.58]	.022 [0.56]	.015 [0.38]

Series: QSS / QTS 0,635mm High Speed Socket / Terminal Strips

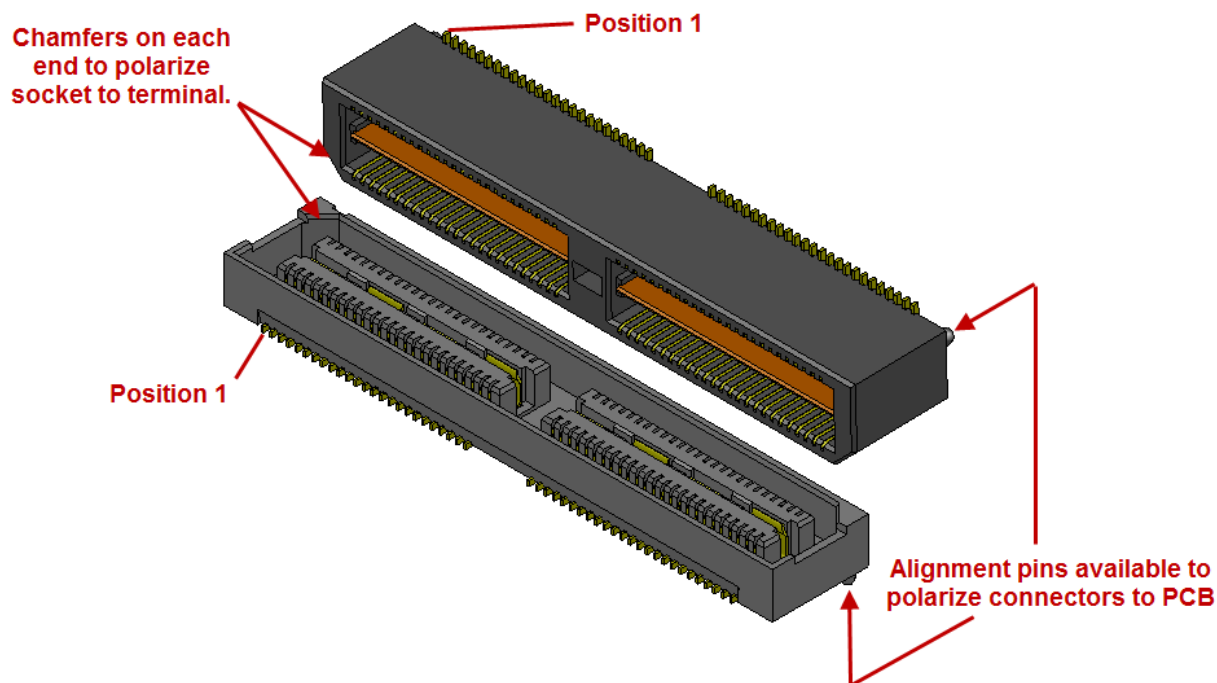
5.0 POLARIZING FEATURES



6.0 HIGH SPEED PERFORMANCE

6.1 Based on a 3 dB insertion loss

6.2 System Impedance: 50 ohm for single-ended and 100 ohm for differential pair

Stack Height	Single-Ended Signaling	Differential Pair Signaling
5mm	9.00 GHz	8.50 GHz
11mm	6.00 GHz	5.50 GHz
16mm	5.00 GHz	5.00 GHz

Series: QSS / QTS 0,635mm High Speed Socket / Terminal Strips

7.0 PROCESSING RECOMMENDATIONS

7.1 Mating Alignment Requirements: The parts can be misaligned by no more than .004" in the X- and Y-direction to ensure a good mate.

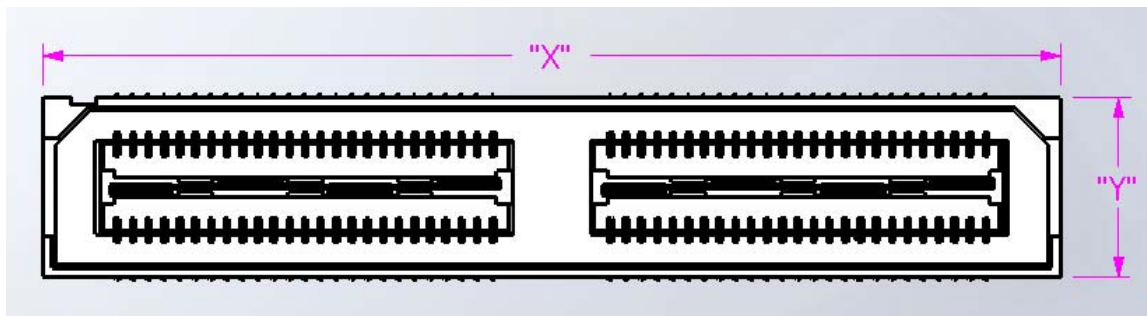

7.2 Mating Angle Requirements: The maximum unmating angle is 2 degrees in the longitudinal direction only.

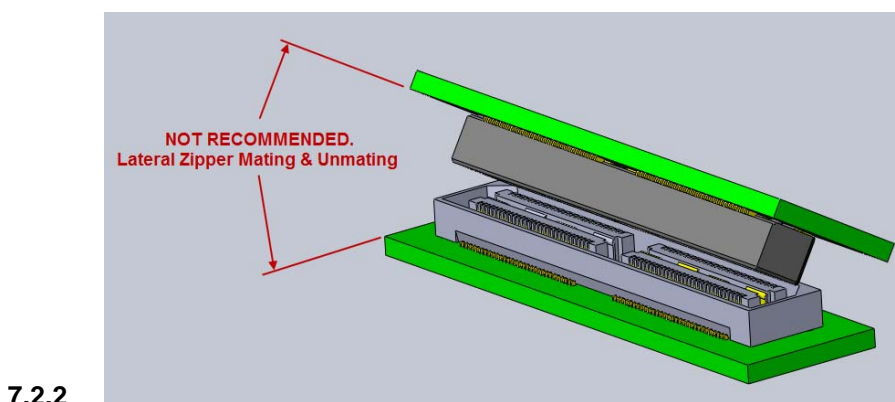
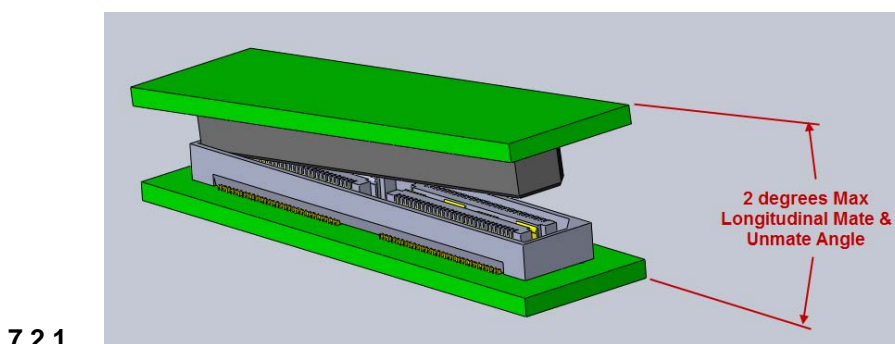

7.3 Maximum Reflow Passes: The parts can withstand 3 reflow passes at a maximum oven temperature of 260°C.

7.4 Stencil Thickness: The recommended stencil thickness is .006" (.15mm).

7.5 Placement: Machine placement of the parts is recommended.

7.6 Thermal Profile: Due to the large number of processing variables (printed wiring board design, reflow oven

Series: [QSS / QTS](#) 0,635mm High Speed Socket / Terminal Strips

type, component quantity, solder paste type, etc.), Samtec does not provide specific reflow profiles for any connector. We recommend that the solder paste manufacturer’s guidelines be followed for optimum soldering results.

- 7.7 Reflow Environment:** Samtec recommends the use of a low level oxygen environment (typically achieved through Nitrogen gas infusion) in the reflow process to improve solderability.
- 7.8 Rework Guidelines:** Samtec recommends following these rework guidelines as needed: [QXX/BXX Connector Rework Methods](#)
- 7.9 Hardware:** Board-to-board standoffs are recommended to provide a robust mechanical connection. Samtec’s wide variety of standoff options can be found here: [SO - Board Stacking Standoff](#)

8.0 DIRECTION OF BOARD TRAVEL THROUGH REFLOW OVEN

8.1 To minimize the potential for connector warpage, Samtec recommends the layout configuration shown below left. This allows the connectors to heat more evenly.

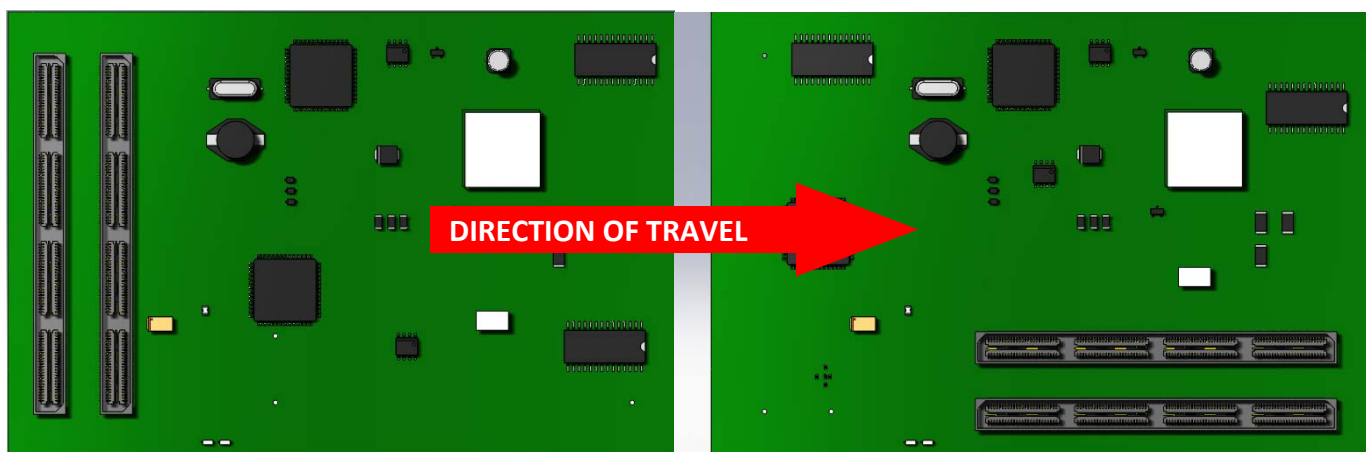

Correct

Incorrect

9.0 ADDITIONAL RESOURCES

- 9.1 For additional mechanical testing or product information, contact our Customer Engineering Support Group at CES@samtec.com
- 9.2 For additional information on high speed performance testing, contact our Signal Integrity Group at SIG@samtec.com
- 9.3 For additional processing information, contact our Interconnect Processing Group at IPG@samtec.com.
- 9.4 For RoHS, REACH or other environmental compliance information, contact our Product Environmental Compliance Group at PEC@samtec.com